

SET-UP NOTES

1. Redesign of this exhibit without approval by Nimlok may result in dangerous and unsafe structures. Nimlok disclaims any responsibility for redesigned exhibits it does not approve in writing.

2. Parts and components such as panels and extrusions are manufactured to metric sizing. Where ever possible sizes have been noted in feet and inches as well as in metric. Below is the imperial to metric sizing table as reference. "Nominal" refers to approximate size.

NOTE: PARTS MAY COME LOCKED TOGETHER FOR PACKING PURPOSES.

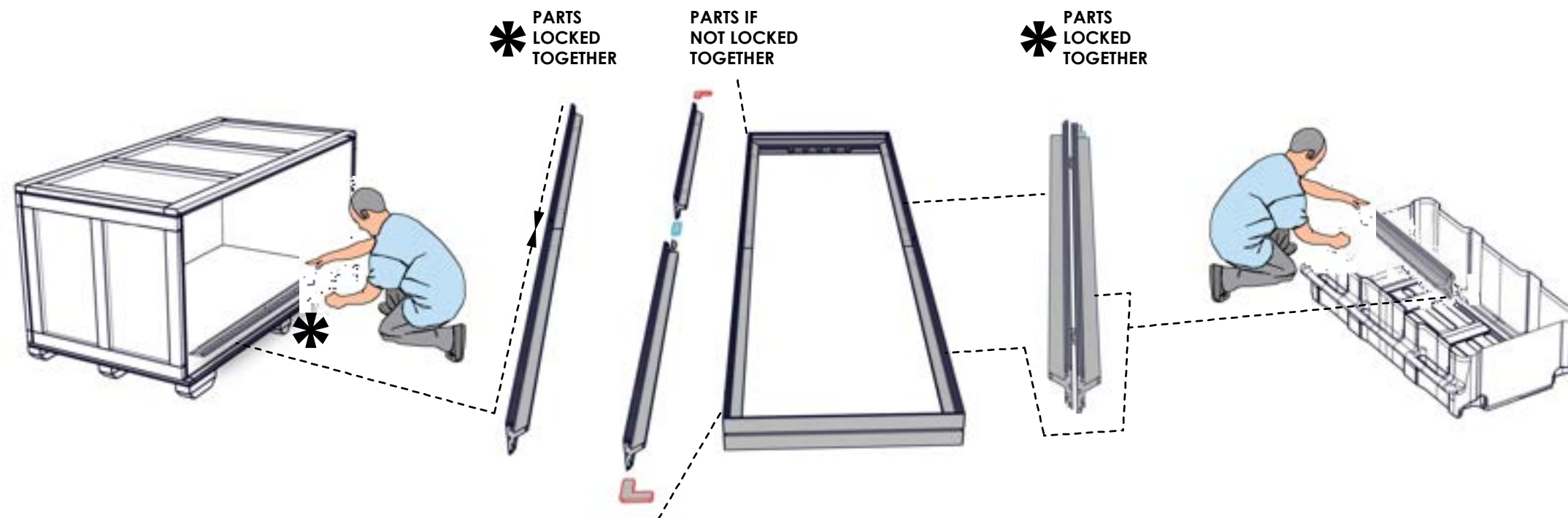

IMPERIAL TO METRIC SIZES

8' Nominal = 94 1/2" or 2400mm Actual
4' Nominal = 47 1/4" or 1200mm Actual
3' Nominal = 35 7/16" or 900mm Actual
2' Nominal = 23 5/8" or 600mm Actual
1' Nominal = 11 13/16" or 300mm Actual

FABRIC, VINYL & UV GRAPHIC CARE GUIDELINES

GENERAL HANDLING FABRIC GRAPHICS

- Your fabric graphics should always be handled in a clean, dry area with clean hands. When possible, use white fabric gloves.
- Be sure fabric is clean and dry before packing.
- Machine washing and/or drying is not recommended for all fabrics. Refer to chart below for which fabrics are washable.

EMERGENCY STAIN TREATMENT (FABRIC)

- For dry stains, like loose dirt or pencil marks, try initially using masking tape or Magic Eraser (dry-not moistened).
 - Masking tape or MagicEraser (dry) can be quite effective at lifting dry, surface dirt. Try 'pulling' as much of stain away as you can. Avoid rubbing stain into fabric.
- Introduce water or liquid cleaner for stains not responsive to masking tape or dry Magic Eraser.
 - When using liquids to treat stains, if at all possible, treat the stain with fabric off of the frame.
 - Place a clean dry cloth behind stain (to absorb stain while being treated). Moisten another cloth initially with just water (distilled water is optimal, if available).
 - Gently blot stain with moistened cloth (or small area of moistened Magic Eraser), while trying to push stain through to the back, using the dry cloth to absorb.
 - Repeat using care to keep the wet area as small as possible.
- Grandma's Secret Spot Remover can be an effective stain remover. Mix several drops in a small cup with clean water. Repeat above technique, taking care to keep wet area as small as possible and using dry cloth on back of stain to absorb.

MACHINE WASHING FABRIC GRAPHICS

- Cold water/delicate cycle/tumble dry low or air dry. For stretch fabrics do not use dryer, let hang dry.
- Use caution on dryer time with graphics containing liners. Its best to put tension fabric on frame when fabric is still damp and let it air dry. Always be sure that the aluminum frame is clean when mounting the damp graphic.
- Fabric stretch graphics that are washed and machine dried may shrink up to 3/4" per every 50" of fabric in the direction of the stretch and shrink up to 1/4" in the non stretch direction.

STORING & PACKING BACKLIT GRAPHICS

- To avoid cracks in the ink or having to steam graphics, Backlit fabrics should be loosely folded with bubble wrap or stored around a tube.
- Avoid folding the graphic tightly to store in a small bag or box.

GENERAL HANDLING VINYL & UV GRAPHICS

- Vinyl banners and rigid graphics should always be handled in a clean, dry area with clean hands. When possible, use white fabric gloves.
- Be sure vinyl/ UV is clean and dry before packing. Always follow material handling and packing instructions included.
- All vinyl materials should be rolled with graphics facing in to protect the graphic printed side. Roll on a tube if available.
- Avoid folding materials to reduce the risk of crease lines and chipped inks. If a graphic must be folded, try to fold loosely and as few times as possible.

EMERGENCY STAIN TREATMENT (UV)

- For drier stains, like loose dirt, pencil marks or adhesive, try initially using masking tape. Masking tape can be quite effective at lifting dry, surface dirt. Try 'pulling' as much of stain away as you can and avoid rubbing the stain into the material.
- When using Solvent to clean a stain be sure to avoid any image. Solvent is aggressive and will take the image off. Soapy water should be used at a ratio of 1 part Dawn® /10 parts water.
- While using Windex® avoid scrubbing harshly. Too much pressure can fade the graphic print.

GENERAL HANDLING OF ROLLABLE PVC PANELS

All mural panels, truss panels and detachables should be rolled with graphics facing out to protect the graphic printed side. Mural panels should be stored in the original plastic sleeves that are provided with the panels.

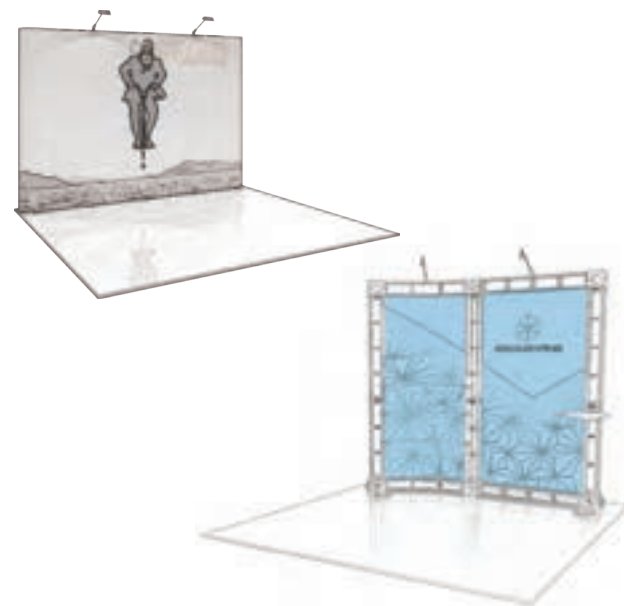

FABRIC, VINYL & UV GRAPHIC CARE GUIDELINES

STEAMING FABRIC GRAPHICS

- For optimal results, steam wrinkles when fabric is tensioned and installed securely on the frame.
- Fill steamer with clean drinking water or distilled water. Avoid using water containing hard minerals.
- Hold steamer upright and hold close to fabric. Avoid touching fabric with steamer.
- Do not tip steamer as water drips may cause water marks to form on graphic.



HANDLING REFERENCE CHART

FABRIC	WASHING MACHINE	DRY CLEAN	SPOT CLEAN	STEAMING/ IRON	MAGIC ERASER
RESILIENCE	NO	NO	NO	NO	YES (ONLY ON WHITE)
OXFORD	YES	YES	YES	YES	YES
POWER STRETCH	YES	YES	YES	YES	YES
DISPLAY POLYESTER	YES	YES	YES	YES	YES
DISPLAY POLY CONVERTIBLES TABLE THROWS	YES (MUST VELCRO THE TABS)	YES (MUST VELCRO THE TABS)	YES	YES	YES
OUTDOOR FLAG	YES	N/A	YES	YES	YES
CANVAS OUTDOOR	NO	NO	YES	STEAM ONLY	YES
CANVAS LIGHTBOX	NO	NO	NO	STEAM ONLY	YES
AGILITY	YES	YES	YES	(ONLY W/ 100% TENSION)	YES
SUPER STRETCH	YES	YES	YES	(ONLY W/ 100% TENSION)	YES
TRIPLE WHITE	YES	YES	NO	YES	NO
ECLIPSE	NO	NO	YES	STEAM ONLY	YES
SOFT KNIT	YES	YES	YES	YES	YES
SHEER	YES	YES	YES	YES	YES

VINYL & ROLLABLE

	SOLVENT	SOAPY WATER (DAWN®)	WINDEX®
FLATMAXX	ONLY ON WHITE	YES	NO
SCRIM 130Z/ 180Z	ONLY ON WHITE	YES	NO
VINYL 200Z	ONLY ON WHITE	YES	NO
MELINEX	NO	YES	NO
MURAL PANELS	NO	YES	YES
UV RIDGED	NO	YES	YES



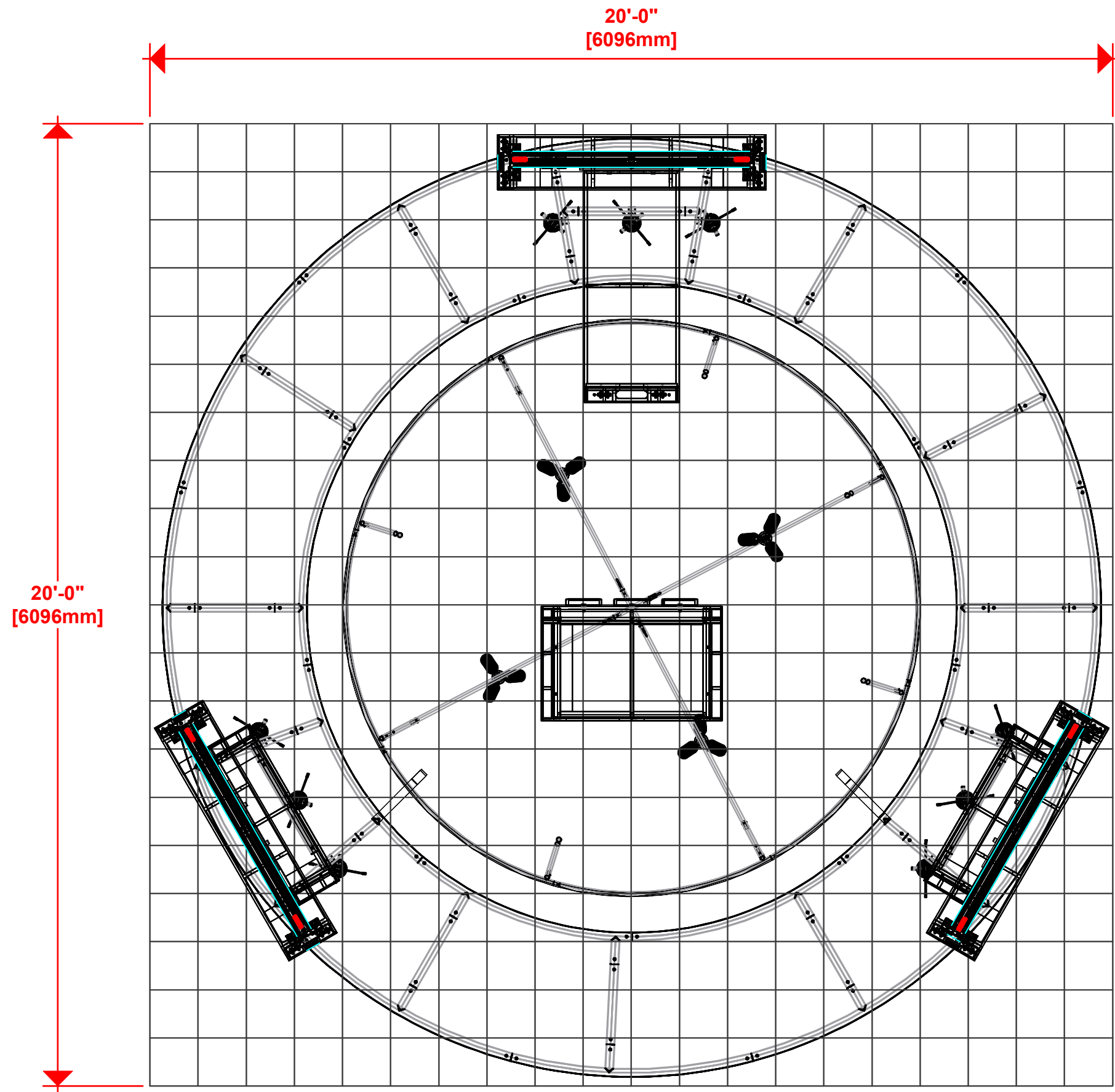

- 2400mm = (94 1/2")
 - 2100mm = (82 5/8")
 - 1800mm = (70 7/8")
 - 1500mm = (59")
 - 1200mm = (47 1/4")
 - 900mm = (35 1/2")
 - 600mm = (23 5/8")
 - 300mm = (11 7/8")
- Phone Line / Fax
 - Internet connection
 - Outlet
 - Main Drop (point of distribution)
 - Wire running under carpet

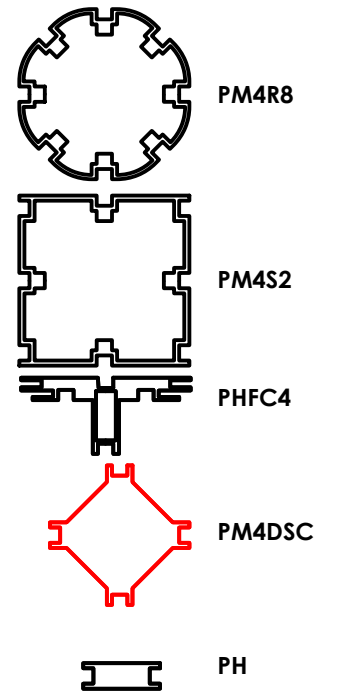

SET UP INSTRUCTIONS:

1. CONNECT BOTTOM AND TOP TUBES FOLLOWING THE LABELS
2. CONNECT SIDE TUBES
3. CLEAN THE FRAME AND PLACE THEM ON CLEAN PLACE
4. CAREFULLY REMOVE FABRIC COVER FROM BAG
5. PLACE COVER AROUND THE BOTTOM OF THE FRAME
6. PULL COVER CAREFULLY UP TO THE TOP
7. CLOSE ALL ZIPPERS
8. ADJUST FABRIC AROUND THE FRAME
9. CONNECT CABLE HARNESS TO THE EYEBOLTS
10. COMPLETELY TIGHTEN THREADED CONNECTORS

BREAK DOWN INSTRUCTIONS:

REVERSE SET-UP STEPS TO BREAKDOWN FRAME

FABRIC CARE INSTRUCTIONS:

1. UNZIP COVER ZIPPERS
2. CAREFULLY REMOVE FABRIC COVER
3. CLOSE ALL ZIPPERS
4. FOLD OR ROLL NEATLY
5. PLACE FABRIC IN COVER BAG

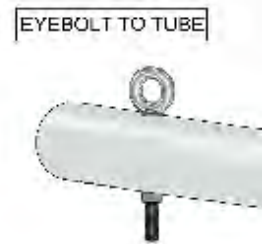
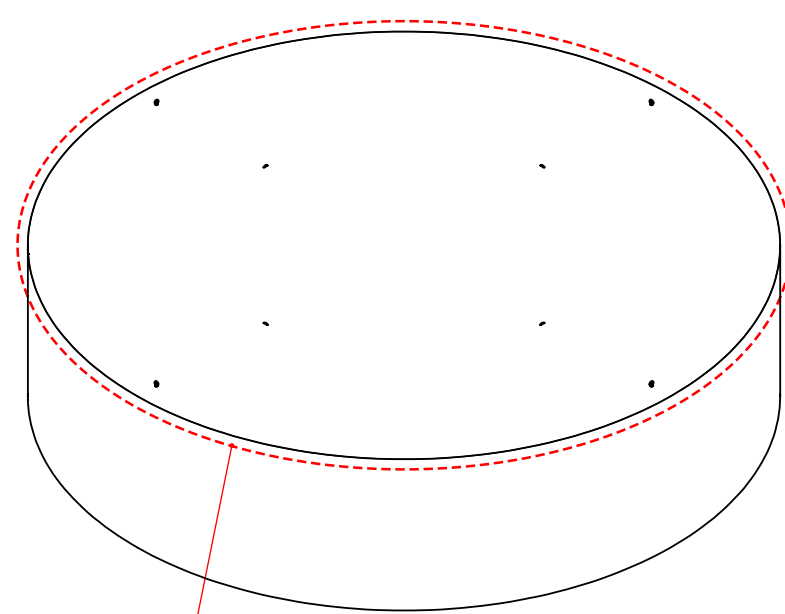

ZIPPERS

SET UP INSTRUCTIONS

REVISIONS				
REV.	DESCRIPTION	INITIALS	DATE	APPROVED

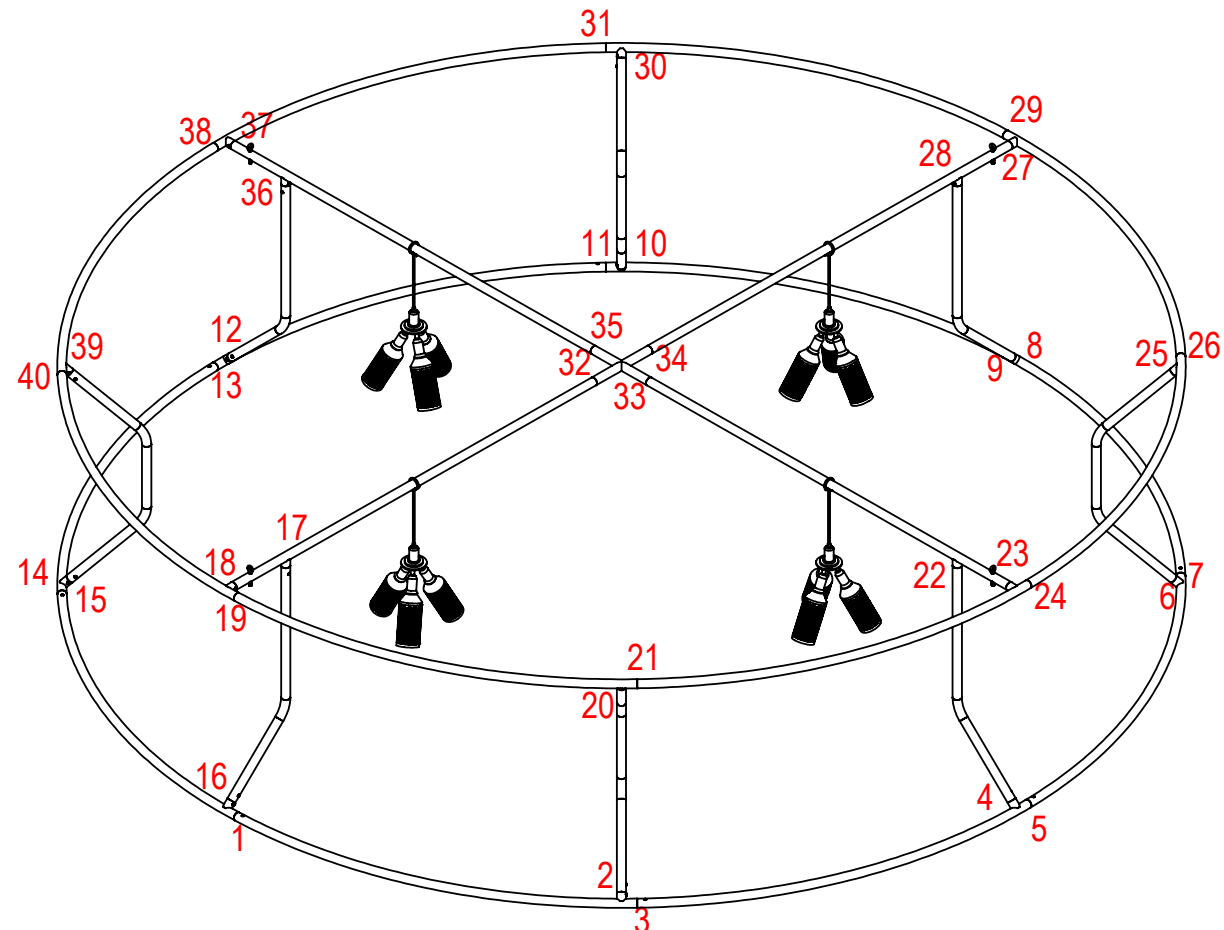

2400mm = (94 1/2")	▼ Phone Line / Fax
2100mm = (82 5/8")	⚡ Internet connection
1800mm = (70 7/8")	⚡ Outlet
1500mm = (59")	⚡ Main Drop (point of distribution)
1200mm = (47 1/4")	
900mm = (35 1/2")	
600mm = (23 5/8")	
300mm = (11 7/8")	
--- Wire running under carpet	

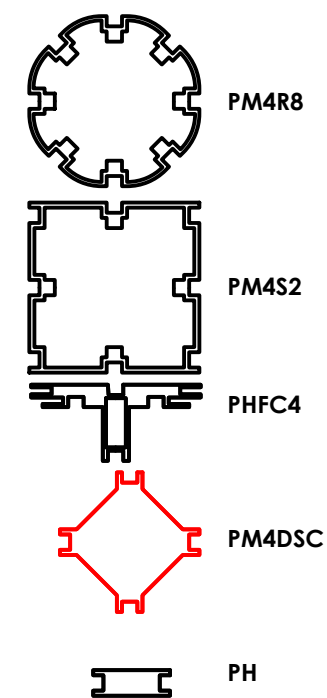

PART NUMBER	DESCRIPTION	None
1451042-B-T3	30mm Anodized Tube	4
1451042-B-T2	30mm Anodized Tube	8
1451042-B-T5	30mm Anodized Tube	4
1451042-B-T6	30mm Anodized Tube	4
1451042-B-T1	30mm Anodized Tube	4
1451042-B-T4	30mm Anodized Tube	4
1451042-B-G	Graphic pillowcase	1
EYEBOLTS-0.25-20-2	2" SHANK 0.25-20 THREADED EYE BOLT	4
TC30-C_SB_90DEG	TUBING ADAPTER FOR 30MM TUBING	8
TC-30-C	TUBING ADAPTER FOR 30MM TUBING	12
LH-3WAY-SOCKET-12IN CORD	LH-3WAY-SOCKET-12IN CORD	4
CH-SP4-HD-08	4-CABLE SINGLE POINT HEAVY DUTY HARNESS WITH 96" LENGTHS 1/8" CABLE	1
1451042-B-T7	30mm Anodized Tube	1
ES30	EXPANDING SPIGOT FOR 30MM TUBE	4

Code	#	Description
GRAPHIC (E1)	1	(148.02 w X 148.02 h total size) 144.02 w X 144.02 h

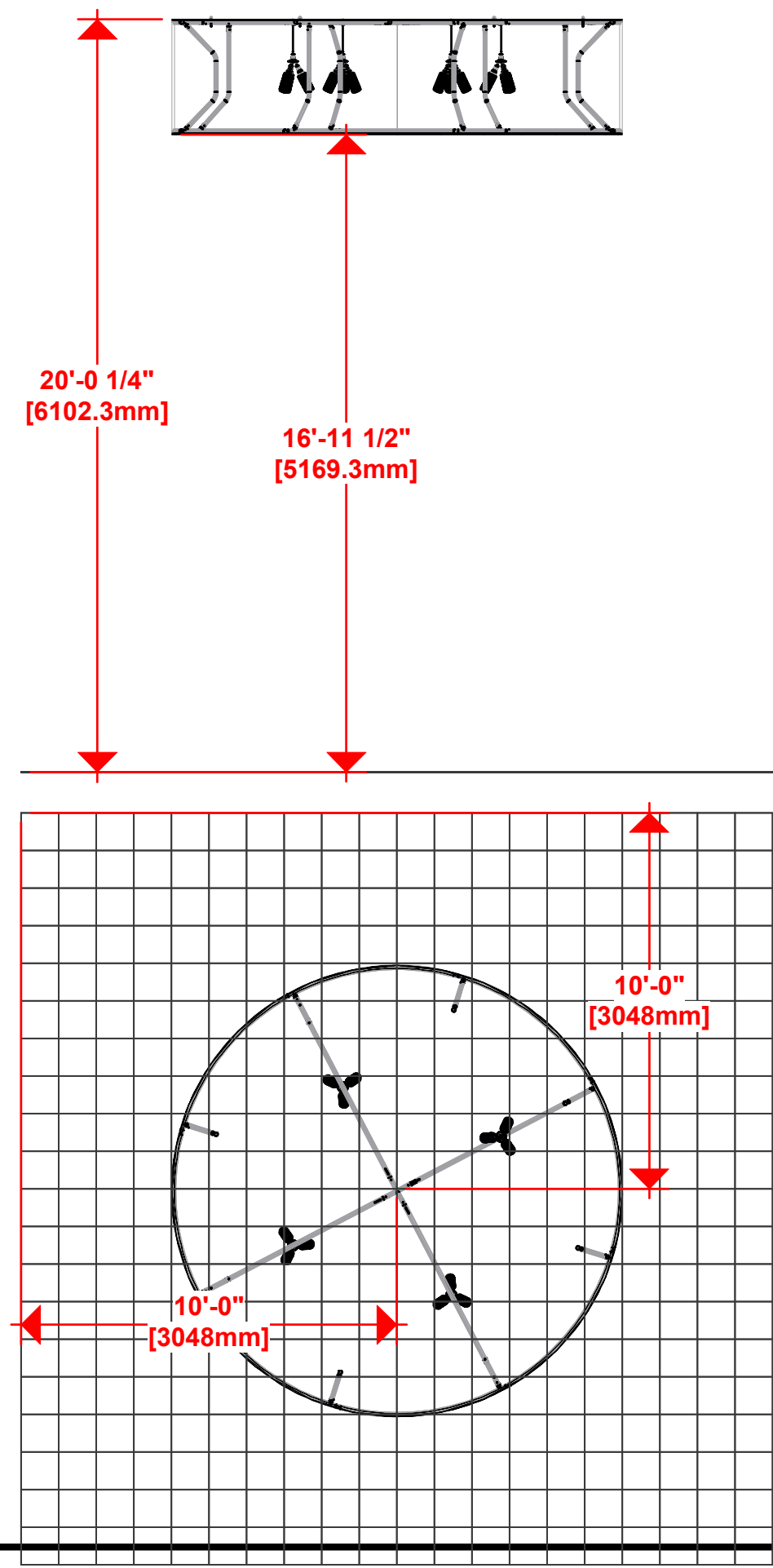
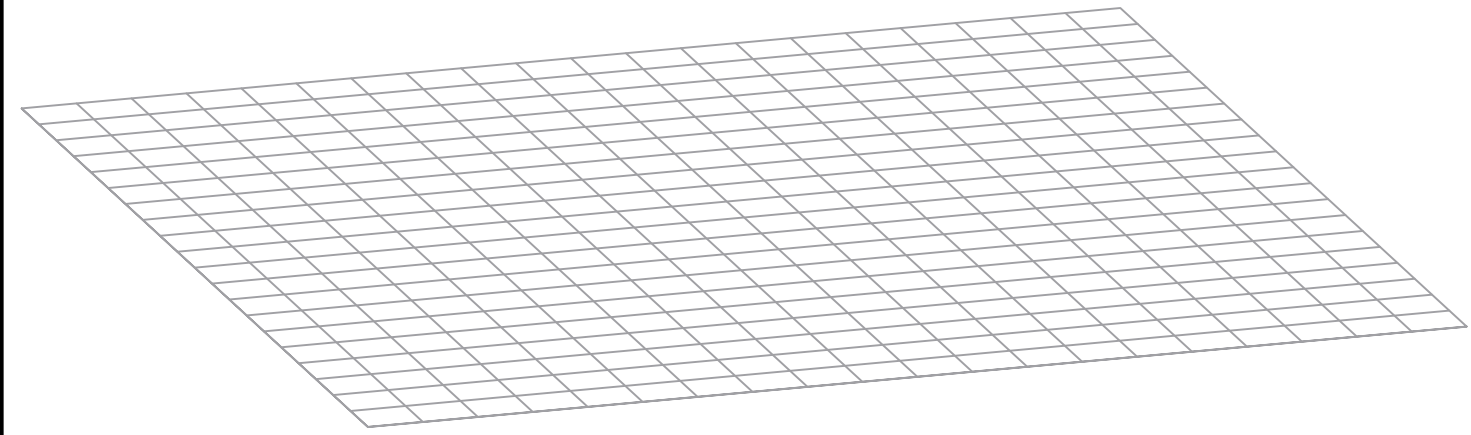
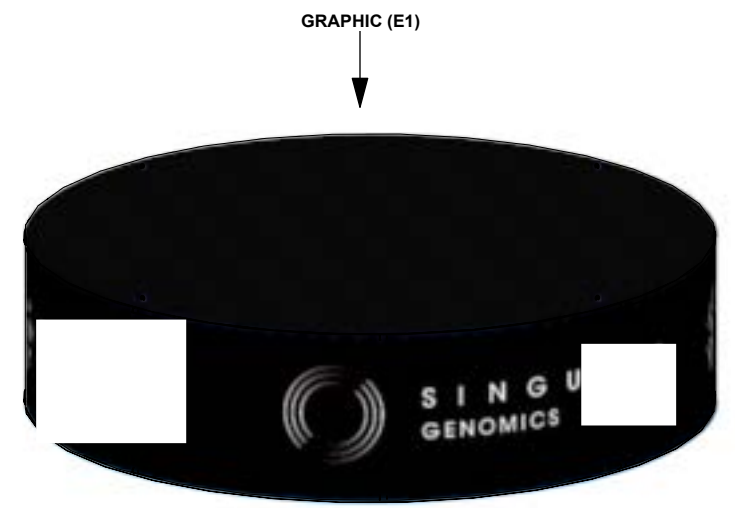

- 2400mm = (94 1/2") Phone Line / Fax
- 2100mm = (82 5/8") Internet connection
- 1800mm = (70 7/8") Outlet
- 1500mm = (59") Main Drop (point of distribution)
- 1200mm = (47 1/4")
- 900mm = (35 1/2")
- 600mm = (23 5/8")
- 300mm = (11 7/8")
- Wire running under carpet

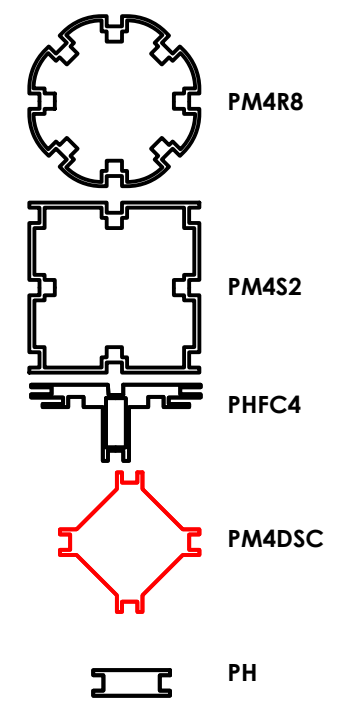

Code	#	Description
A8	1	1500MM LENGTH OF PHFC4 EXTRUSION-WITH MITRE CUT BOTH ENDS-WITH GROMMET HOLE
A10	2	2400MM LENGTH OF PHFC4 EXTRUSION-WITH MITRE CUT FOR CB9 ONE END-IB2 LOCK HOLE ONE END-WITH SIDE LOCKS-WITH GROMMET
A7	2	900MM LENGTH OF PHFC4 EXTRUSION-WITH MITRE CUT FOR CB9 ONE END-IB2 LOCK HOLE ONE END-WITH SIDE LOCKS
A9	1	1500MM LENGTH OF PHFC4 EXTRUSION-WITH MITRE CUT BOTH ENDS-WITH SIDE LOCKS-WITH GROMMET HOLE
A3	1	1410MM CUT DOWN FROM 1500MM LENGTH OF PH EXTRUSION-WITH SLIDE LOCKS BOTH ENDS
A4	1	1410MM CUT DOWN FROM 1500MM LENGTH OF PM4R8 EXTRUSION-WITH CAM LOCKS BOTH ENDS
A5	1	1410MM CUT DOWN FROM 1500MM LENGTH OF PM4S2 EXTRUSION-WITH CAM LOCKS BOTH ENDS
CB9	4	90 DEGREE JOINER
IB2-O	2	JOINER BAR (OLD STYLE)

- 2400mm = (94 1/2")
 - 2100mm = (82 5/8")
 - 1800mm = (70 7/8")
 - 1500mm = (59")
 - 1200mm = (47 1/4")
 - 900mm = (35 1/2")
 - 600mm = (23 5/8")
 - 300mm = (11 7/8")
- Phone Line / Fax
 - Internet connection
 - Outlet
 - Main Drop (point of distribution)
 - Wire running under carpet

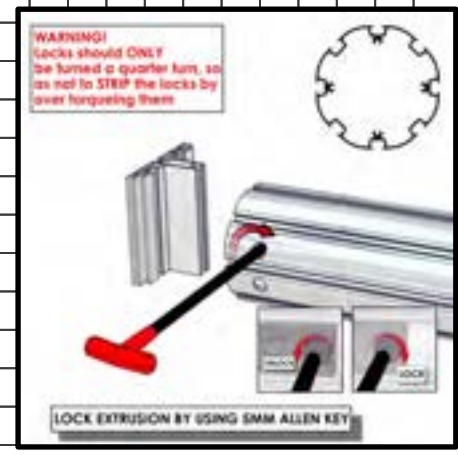
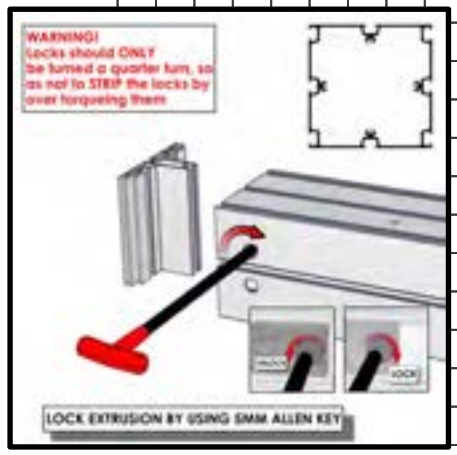
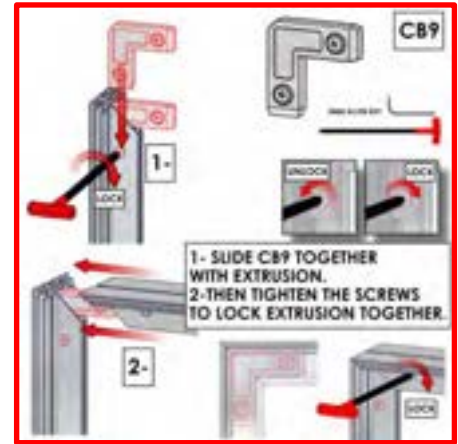
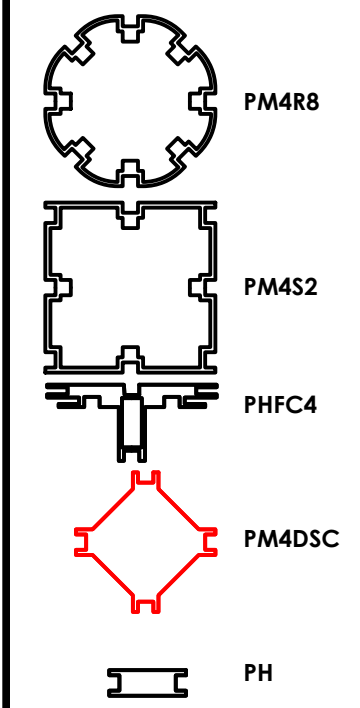
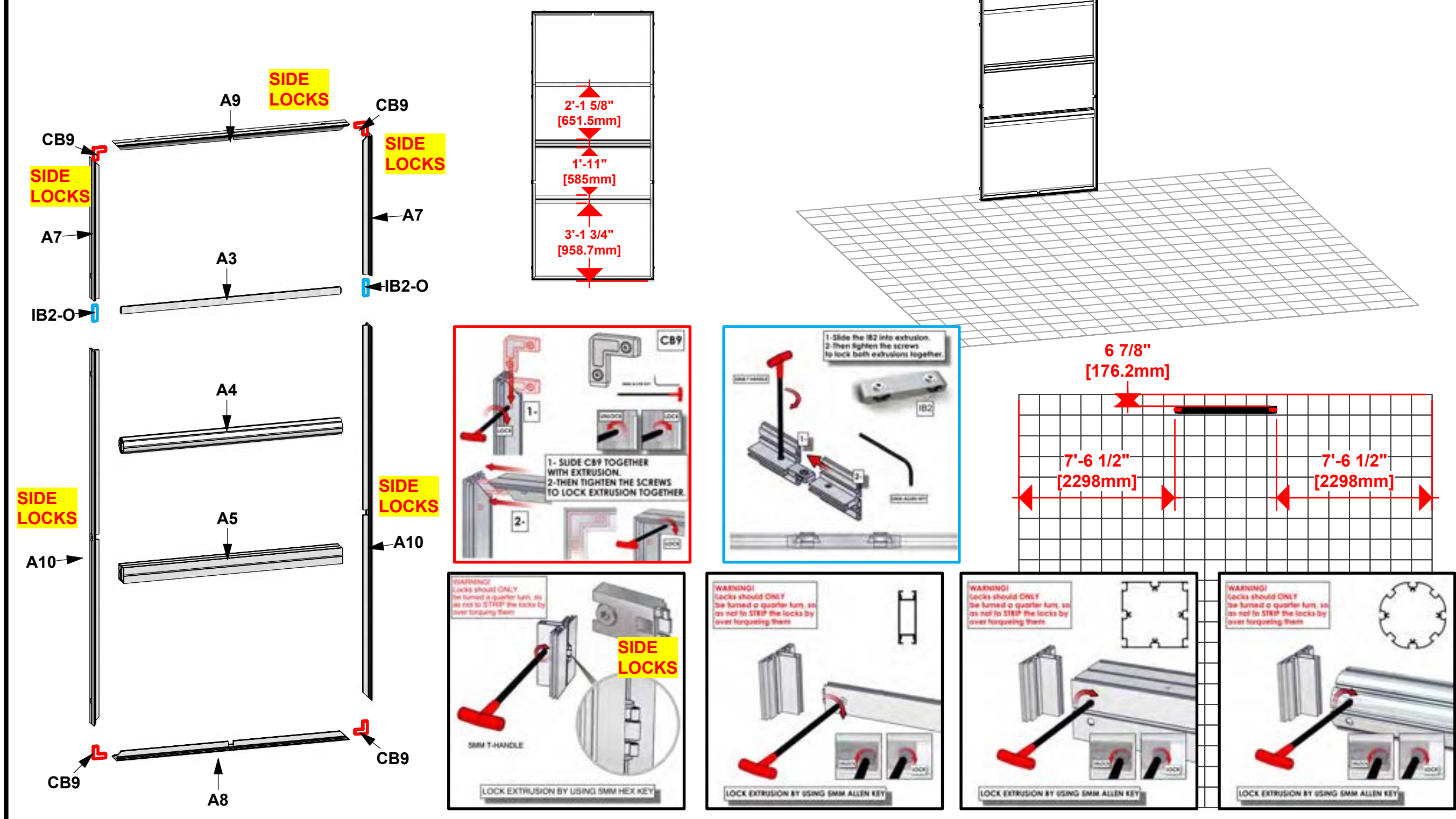

Code	#	Description
PANEL A2	1	WOOD LAMINATE SURROUND FOR VECTORFRAME, W/ CURVED CORNERS AND WIRE MANAGEMENT IN TOP. 1700MM
PANEL A5	1	WOOD LAMINATE SURROUND FOR VECTORFRAME, W/ CURVED CORNERS AND WIRE MANAGEMENT IN TOP. 1700MM
PANEL A4	1	WOOD LAMINATE SURROUND FOR VECTORFRAME, W/ CURVED CORNERS AND WIRE MANAGEMENT IN TOP. 1700MM
PANEL A3	1	WOOD LAMINATE SURROUND FOR VECTORFRAME, W/ CURVED CORNERS AND WIRE MANAGEMENT IN TOP. 1700MM
PANEL A1	1	WOOD LAMINATE SURROUND FOR VECTORFRAME, W/ CURVED CORNERS AND WIRE MANAGEMENT IN TOP. 1700MM

LOCK FRAME TO WOOD PANELS

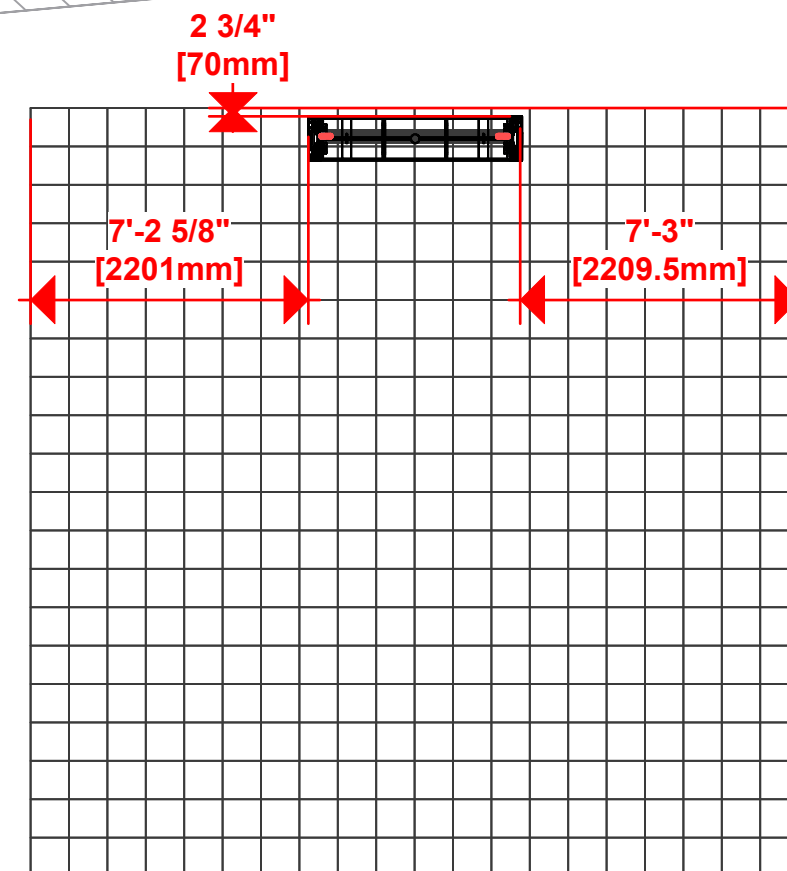
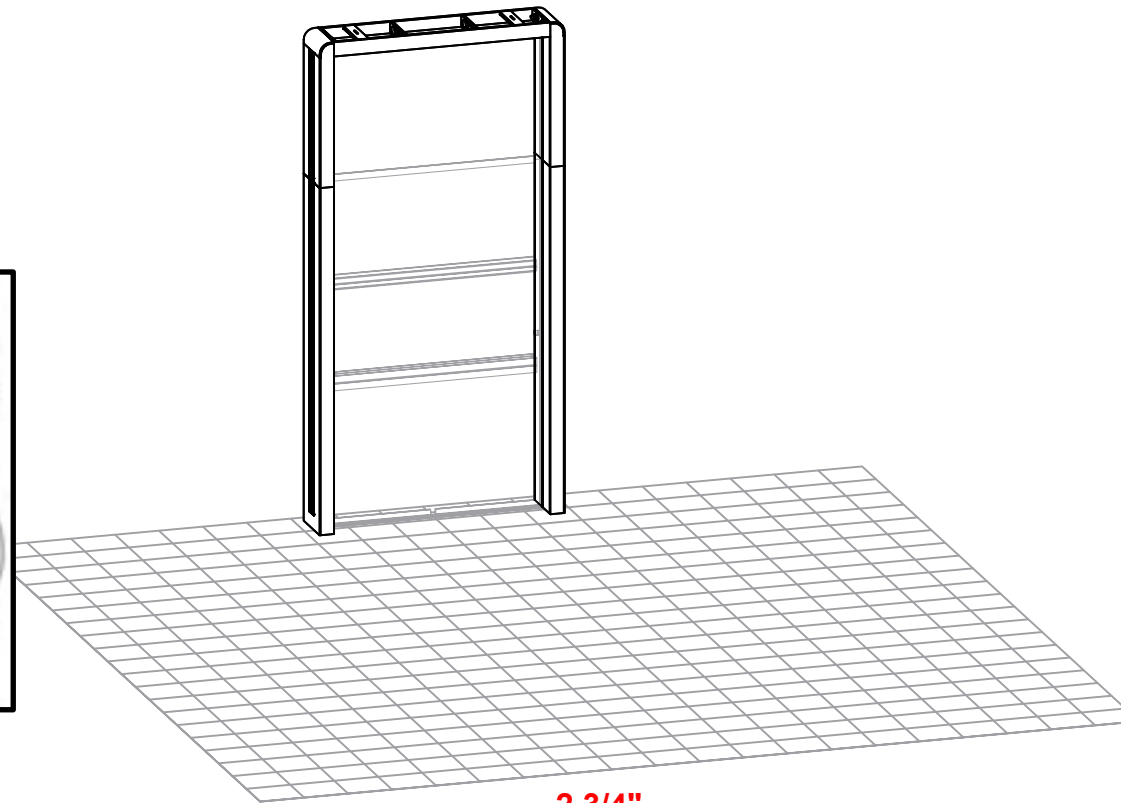
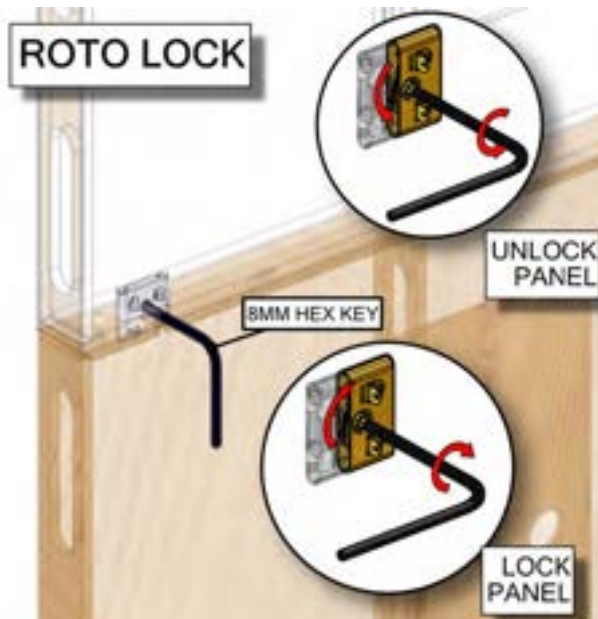
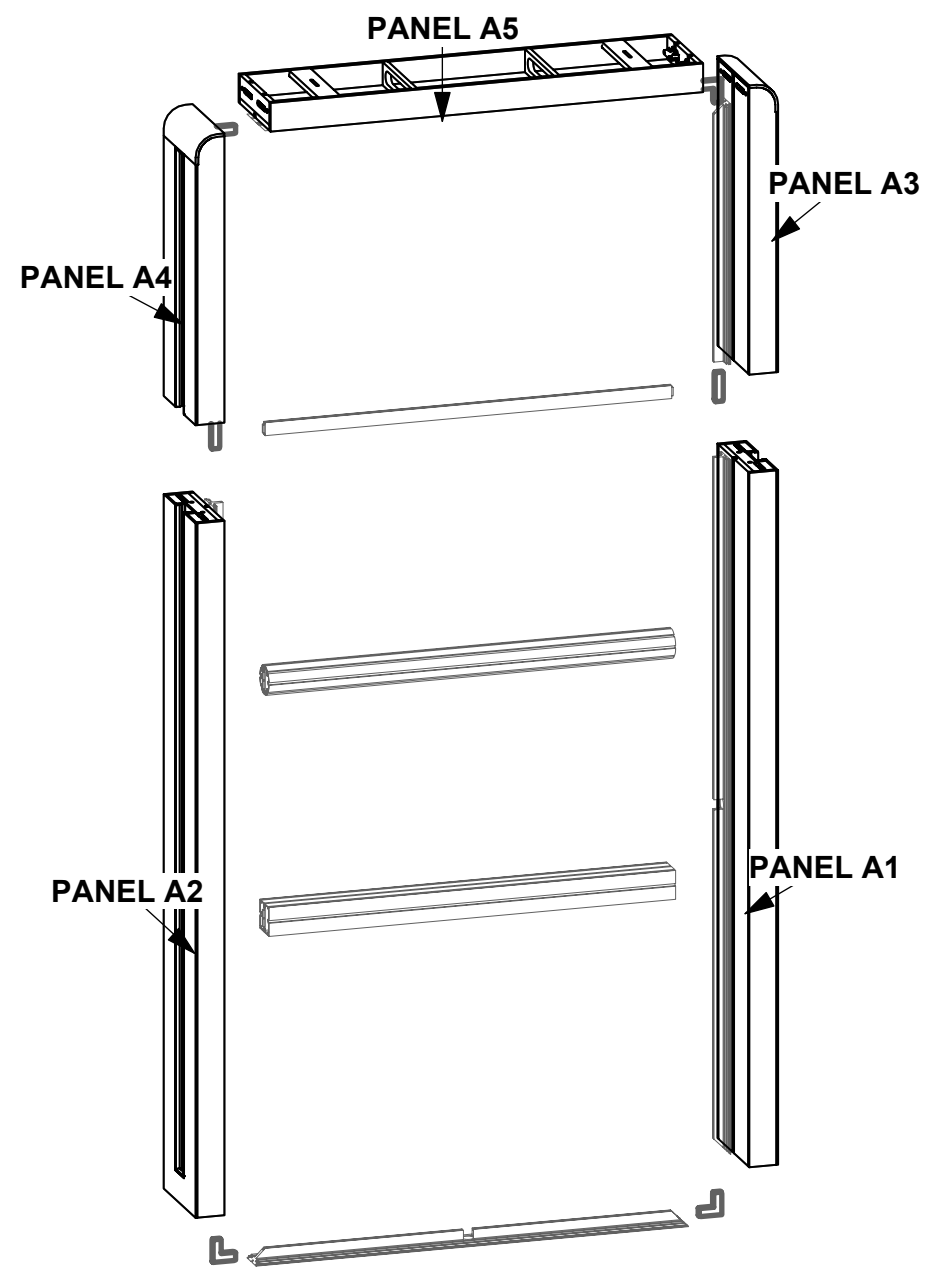



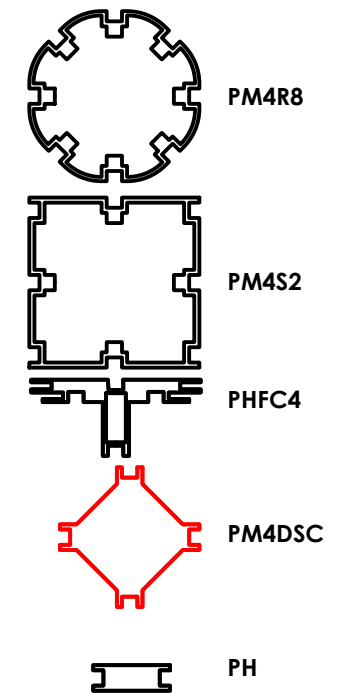

2400mm = (94 1/2")
 2100mm = (82 5/8")
 1800mm = (70 7/8")
 1500mm = (59")
 1200mm = (47 1/4")
 900mm = (35 1/2")
 600mm = (23 5/8")
 300mm = (11 7/8")

Phone Line / Fax
 Internet connection
 Outlet
 Main Drop (point of distribution)
 Wire running under carpet



Code	#	Description
A8	2	1500MM LENGTH OF PHFC4 EXTRUSION-WITH MITRE CUT BOTH ENDS-WITH GROMMET HOLE
A10	4	2400MM LENGTH OF PHFC4 EXTRUSION-WITH MITRE CUT FOR CB9 ONE END-IB2 LOCK HOLE ONE END-WITH SIDE LOCKS-
A7	4	900MM LENGTH OF PHFC4 EXTRUSION-WITH MITRE CUT FOR CB9 ONE END-IB2 LOCK HOLE ONE END-WITH SIDE LOCKS
A9	2	1500MM LENGTH OF PHFC4 EXTRUSION-WITH MITRE CUT BOTH ENDS-WITH SIDE LOCKS-WITH GROMMET HOLE
A3	2	1410MM CUT DOWN FROM 1500MM LENGTH OF PH EXTRUSION-WITH SLIDE LOCKS BOTH ENDS
A5	2	1410MM CUT DOWN FROM 1500MM LENGTH OF PM4S2 EXTRUSION-WITH CAM LOCKS BOTH ENDS
A4	2	1410MM CUT DOWN FROM 1500MM LENGTH OF PM4R8 EXTRUSION-WITH CAM LOCKS BOTH ENDS
CB9	8	90 DEGREE JOINER
IB2-O	4	JOINER BAR (OLD STYLE)

2400mm = (94 1/2")
 2100mm = (82 5/8")
 1800mm = (70 7/8")
 1500mm = (59")
 1200mm = (47 1/4")
 900mm = (35 1/2")
 600mm = (23 5/8")
 300mm = (11 7/8")

 Phone Line / Fax
 Internet connection
 Outlet
 Main Drop (point of distribution)
 Wire running under carpet

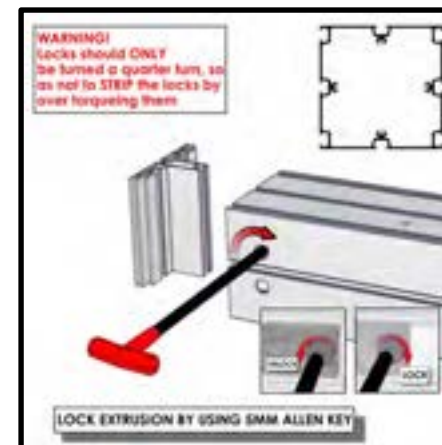
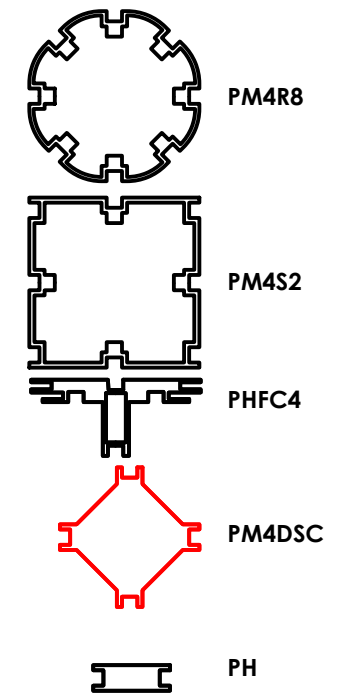
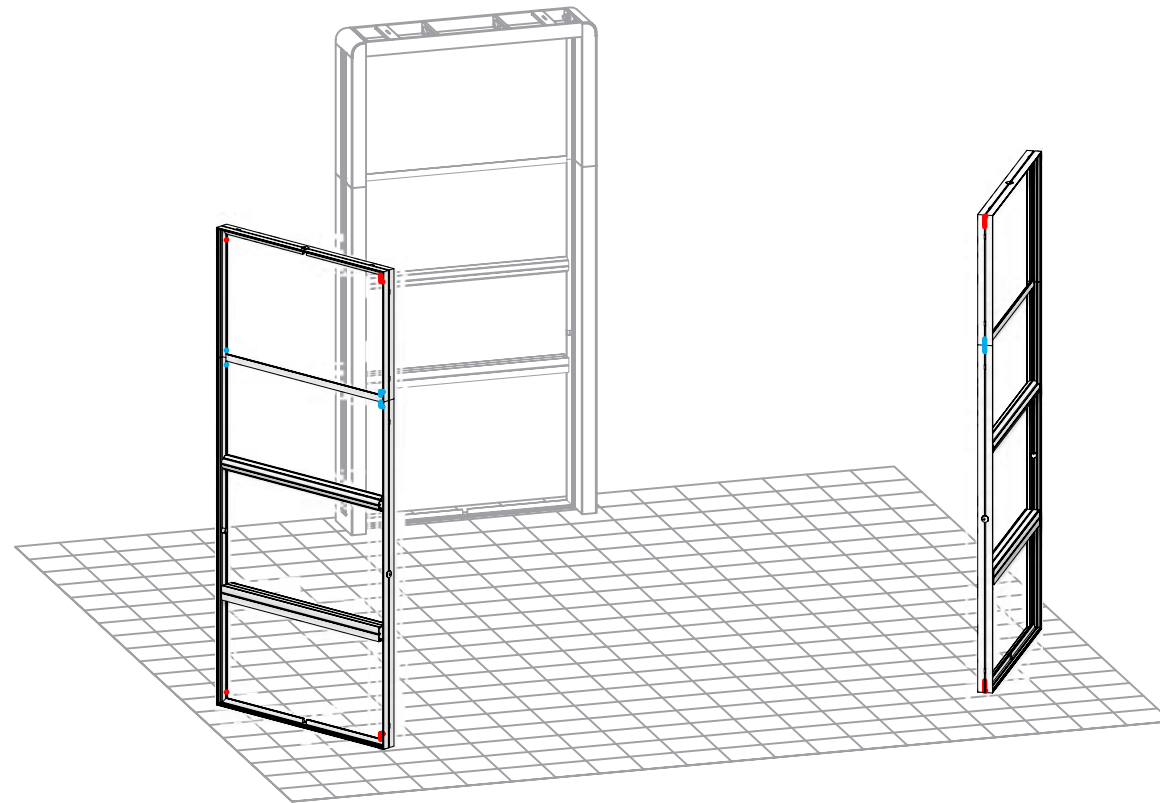
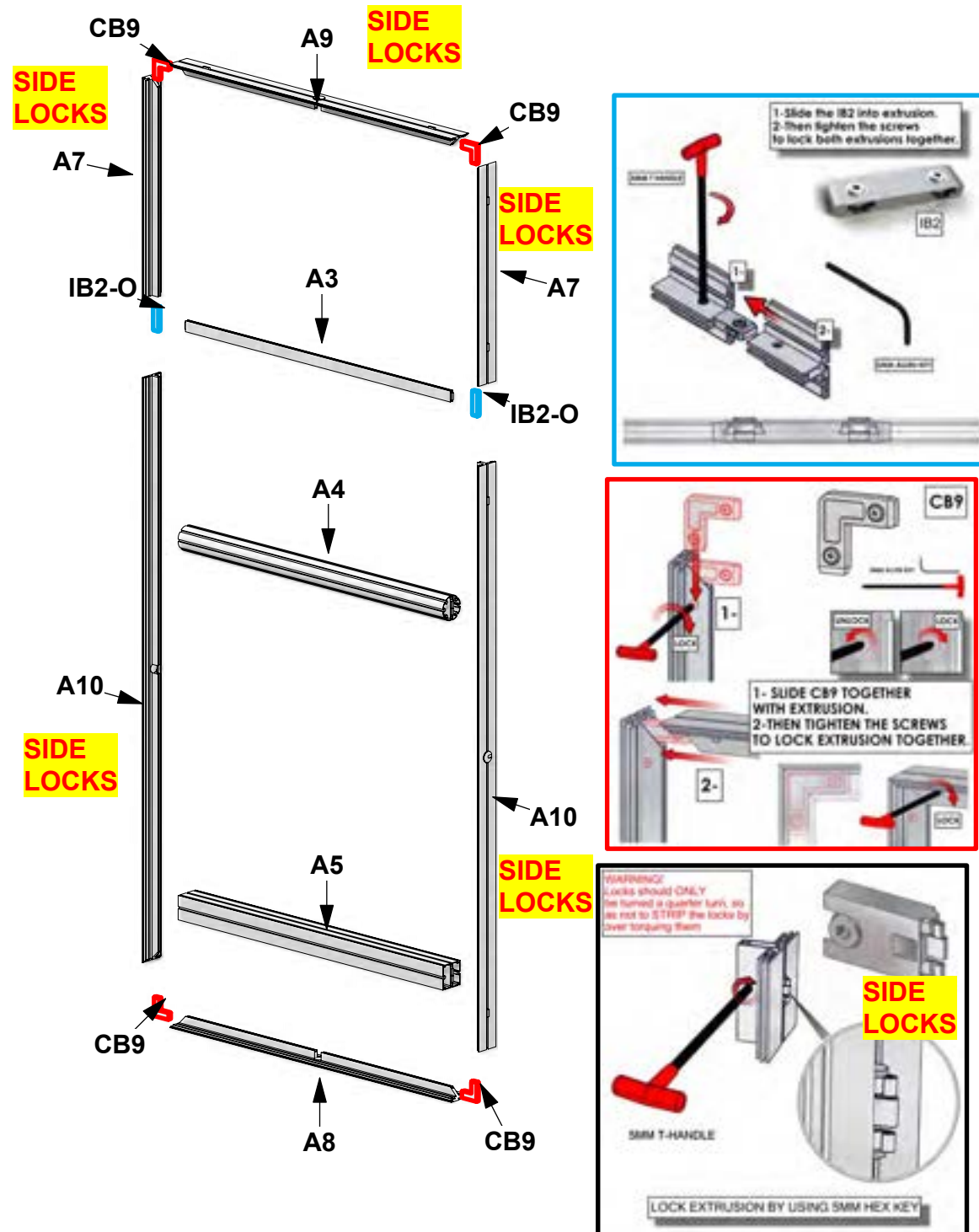

Code	#	Description
PANEL B1	1	WOOD LAMINATE SURROUND FOR VECTORFRAME, W/ CURVED CORNERS AND WIRE MA
PANEL B5	1	WOOD LAMINATE SURROUND FOR VECTORFRAME, W/ CURVED CORNERS AND WIRE MA
PANEL B3	1	WOOD LAMINATE SURROUND FOR VECTORFRAME, W/ CURVED CORNERS AND WIRE MA
PANEL B4	1	WOOD LAMINATE SURROUND FOR VECTORFRAME, W/ CURVED CORNERS AND WIRE MA
PANEL B2	1	WOOD LAMINATE SURROUND FOR VECTORFRAME, W/ CURVED CORNERS AND WIRE MA
PANEL C2	1	WOOD LAMINATE SURROUND FOR VECTORFRAME, W/ CURVED CORNERS AND WIRE MA
PANEL C5	1	WOOD LAMINATE SURROUND FOR VECTORFRAME, W/ CURVED CORNERS AND WIRE MA
PANEL C4	1	WOOD LAMINATE SURROUND FOR VECTORFRAME, W/ CURVED CORNERS AND WIRE MA
PANEL C3	1	WOOD LAMINATE SURROUND FOR VECTORFRAME, W/ CURVED CORNERS AND WIRE MA
PANEL C1	1	WOOD LAMINATE SURROUND FOR VECTORFRAME, W/ CURVED CORNERS AND WIRE MA

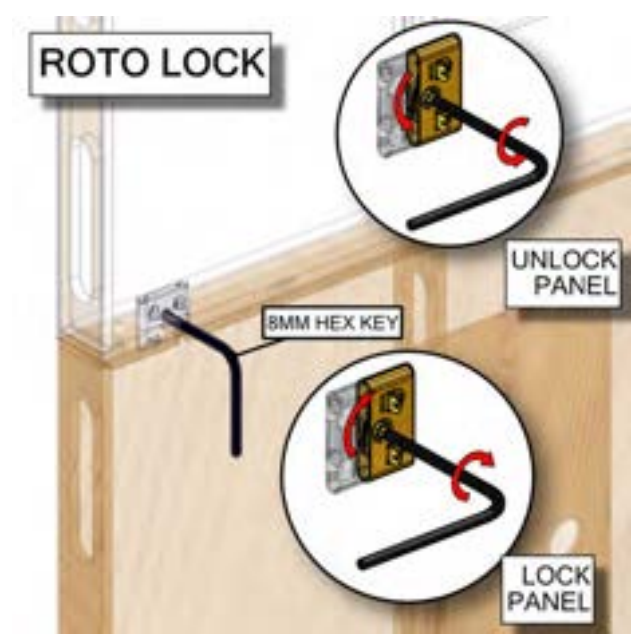
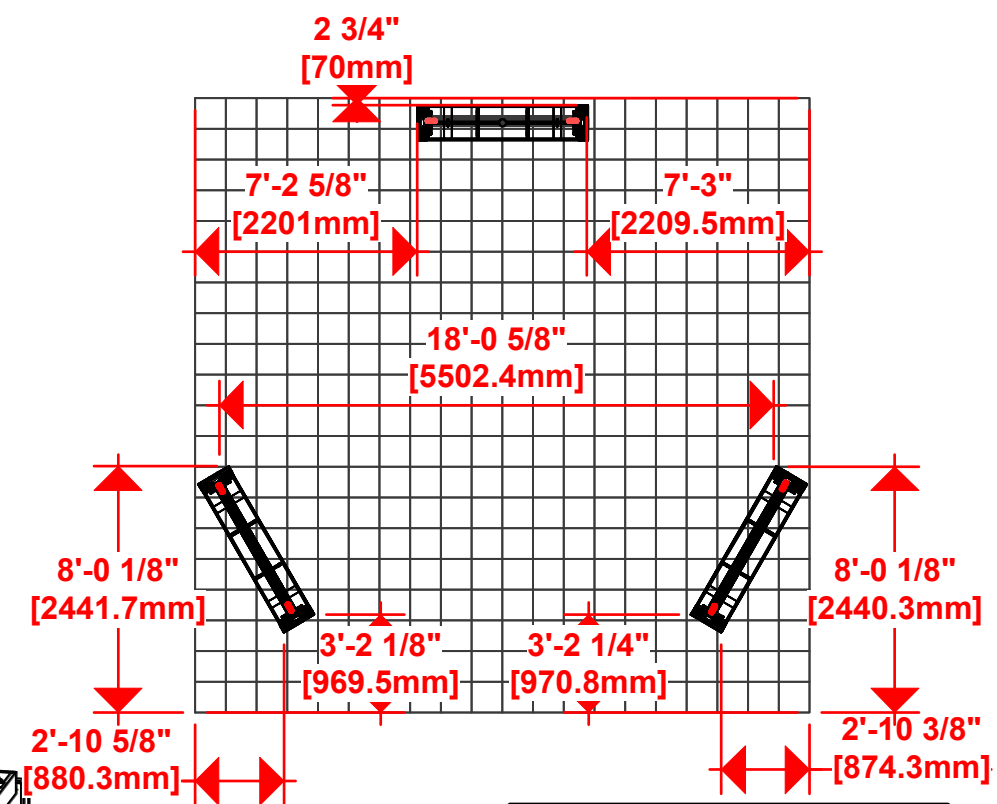
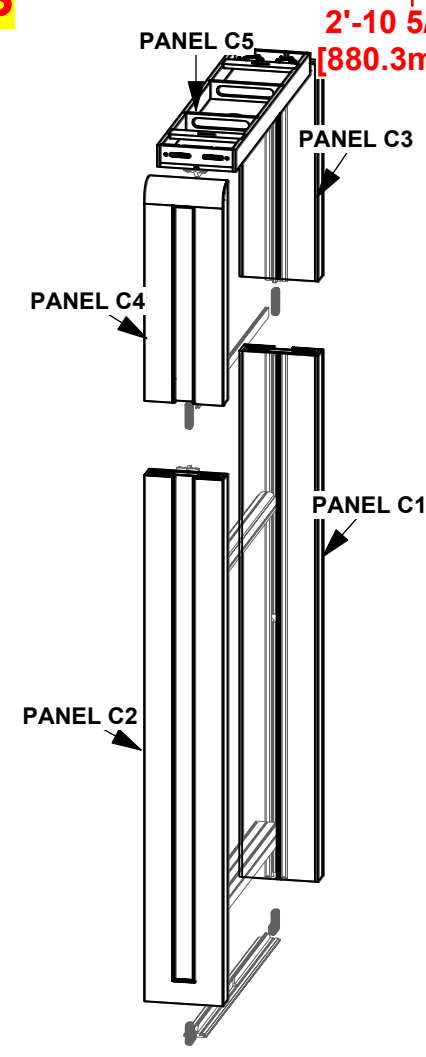
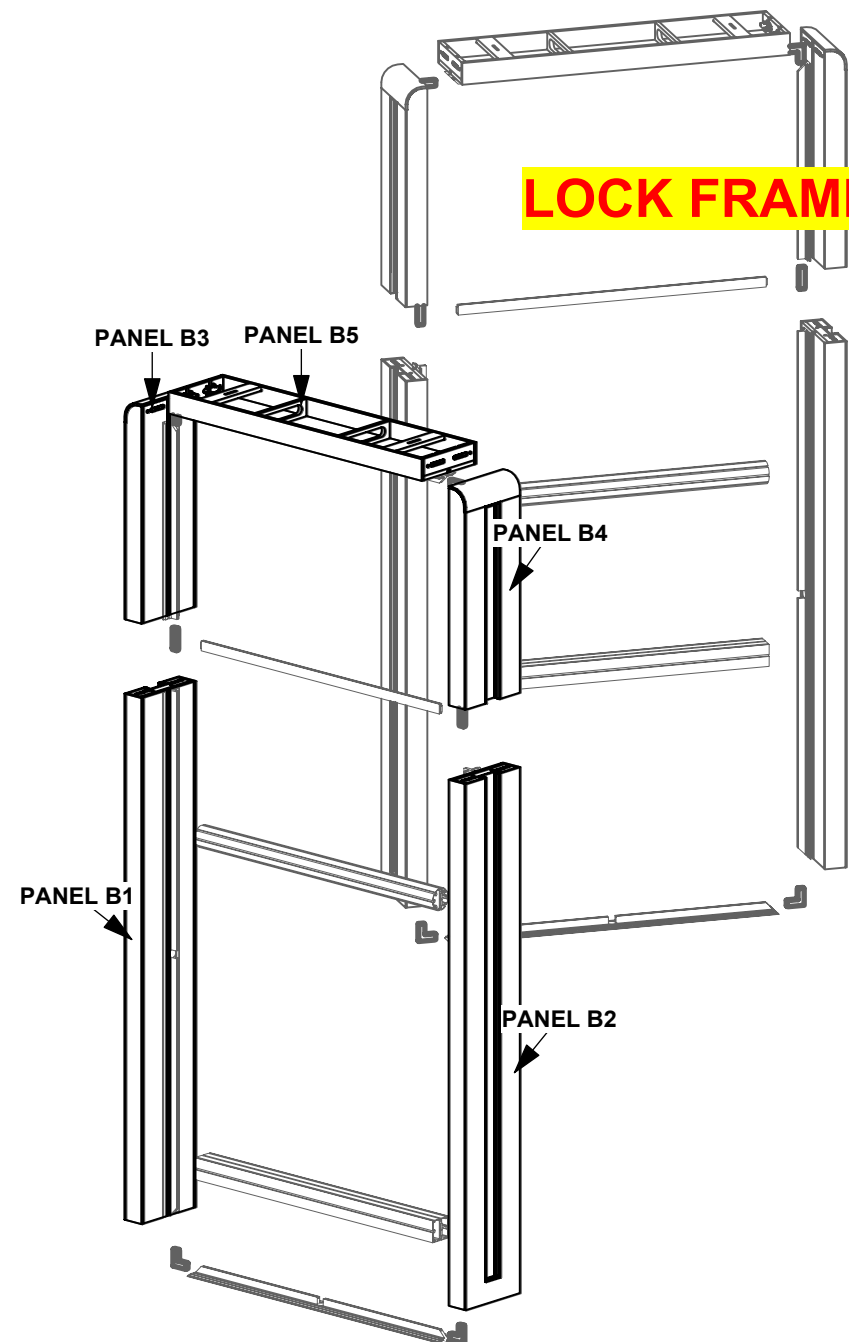

2400mm = (94 1/2")
 2100mm = (82 5/8")
 1800mm = (70 7/8")
 1500mm = (59")
 1200mm = (47 1/4")
 900mm = (35 1/2")
 600mm = (23 5/8")
 300mm = (11 7/8")

Phone Line / Fax
 Internet connection
 Outlet
 Main Drop (point of distribution)
 Wire running under carpet

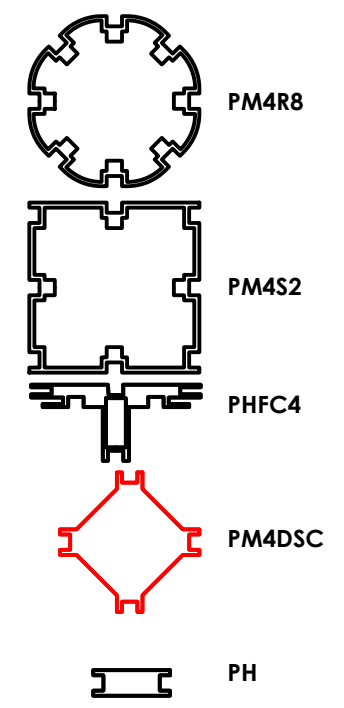

Code	#	Description
GRAPHIC (A2)	1	(62.94 w X 133.80 h total size) 58.94 w X 129.80 h finish size, Dye-sub print on Eclipse Blockout Stretch, single sided, sewn with FCE-2 silicone
GRAPHIC (B2)	1	(62.94 w X 133.80 h total size) 58.94 w X 129.80 h finish size, Dye-sub print on Eclipse Blockout Stretch, single sided, sewn with FCE-2 silicone
GRAPHIC (C2)	1	(62.94 w X 133.80 h total size) 58.94 w X 129.80 h finish size, Dye-sub print on Eclipse Blockout Stretch, single sided, sewn with FCE-2 silicone

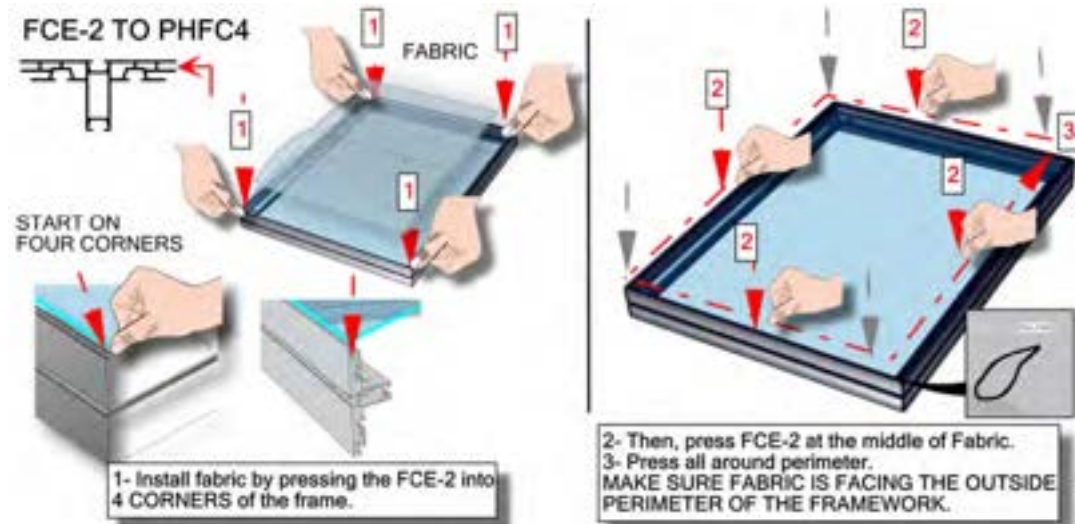

OUTSIDE GRAPHICS

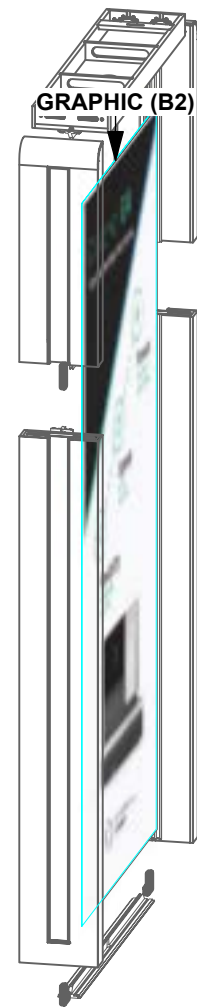
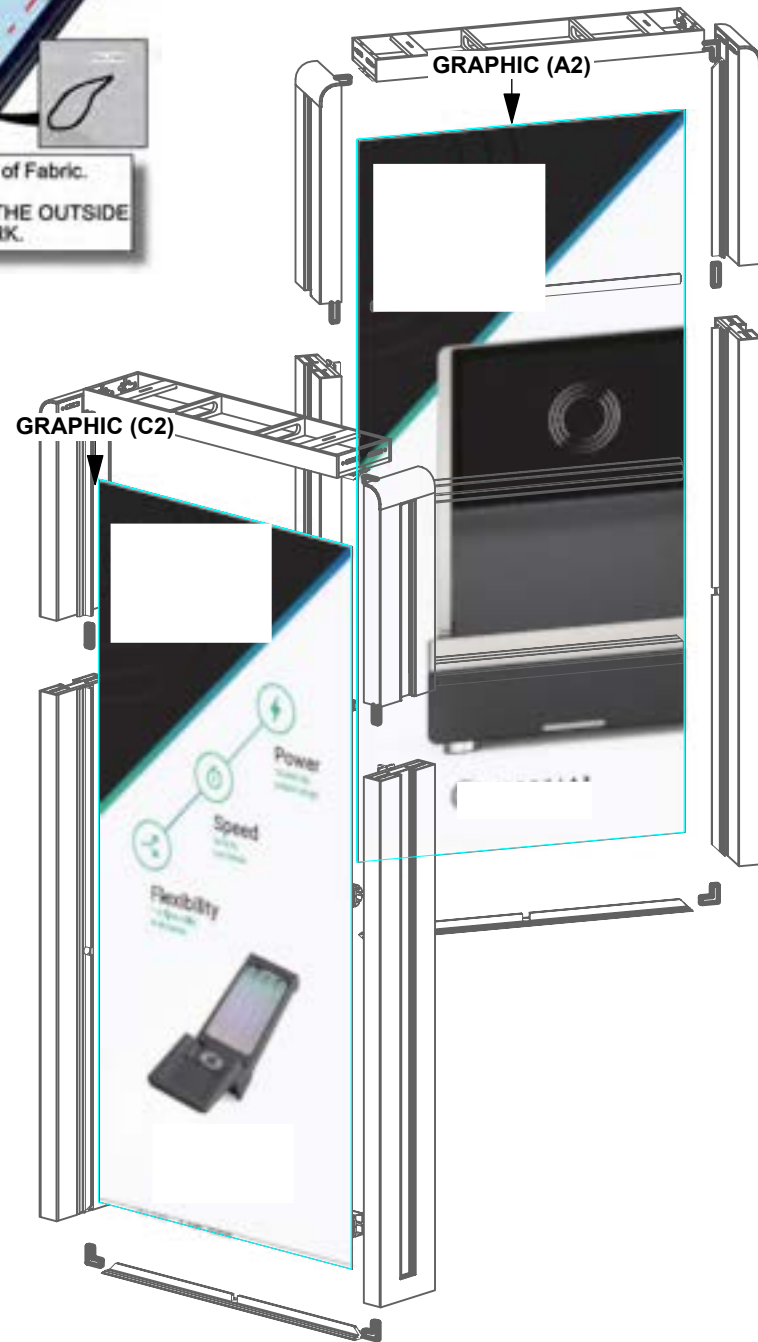
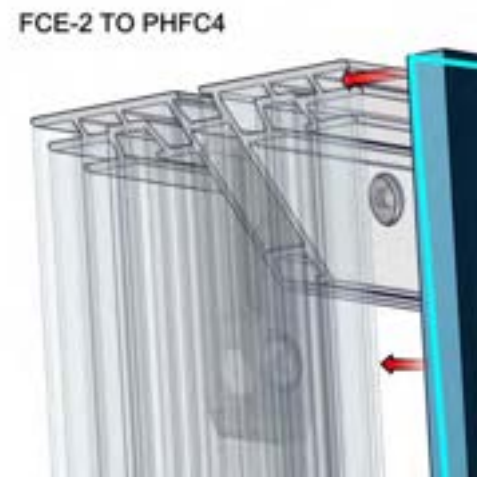

- 2400mm = (94 1/2")
 - 2100mm = (82 5/8")
 - 1800mm = (70 7/8")
 - 1500mm = (59")
 - 1200mm = (47 1/4")
 - 900mm = (35 1/2")
 - 600mm = (23 5/8")
 - 300mm = (11 7/8")
- ☐ Phone Line / Fax
 - ⚡ Internet connection
 - ⚡ Outlet
 - ⚡ Main Drop (point of distribution)
 - Wire running under carpet

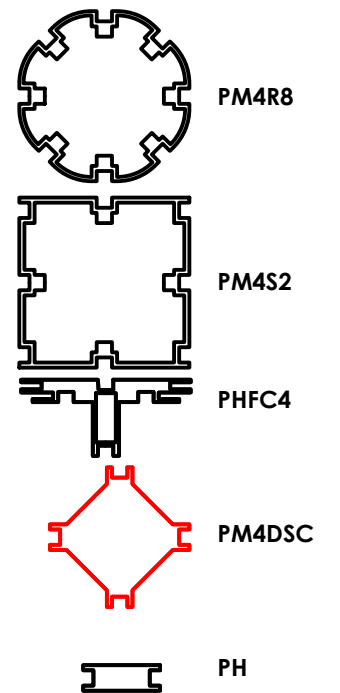

Code	#	Description
GRAPHIC (A1)	1	(62.94 w X 133.80 h total size) 58.94 w X 129.80 h finish size, Dye-sub print on Eclipse Blockout Stretch, single sided, sewn with FCE-2 silicon
GRAPHIC (B1)	1	(62.94 w X 133.80 h total size) 58.94 w X 129.80 h finish size, Dye-sub print on Eclipse Blockout Stretch, single sided, sewn with FCE-2 silicon
GRAPHIC (C1)	1	(62.94 w X 133.80 h total size) 58.94 w X 129.80 h finish size, Dye-sub print on Eclipse Blockout Stretch, single sided, sewn with FCE-2 silicon

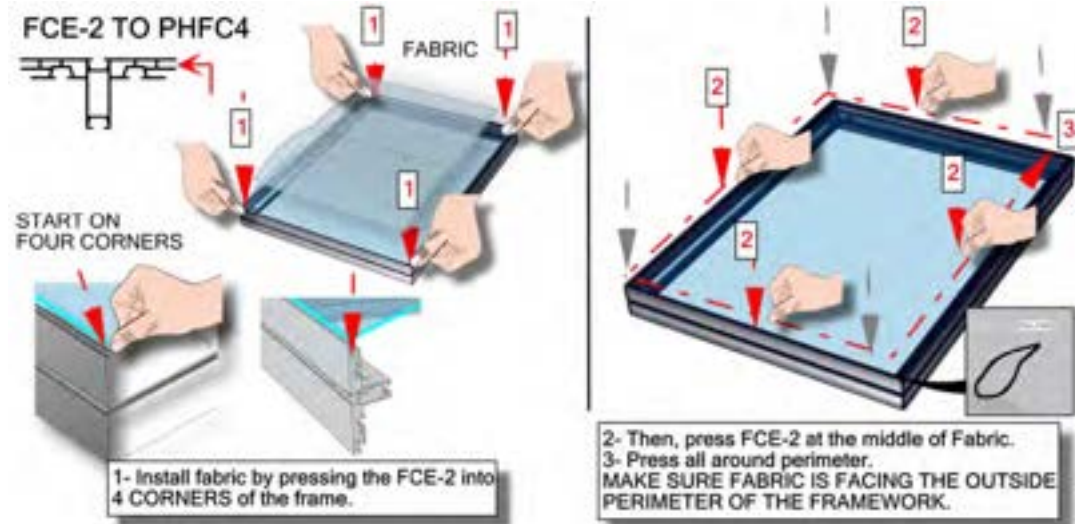

INSIDE GRAPHICS

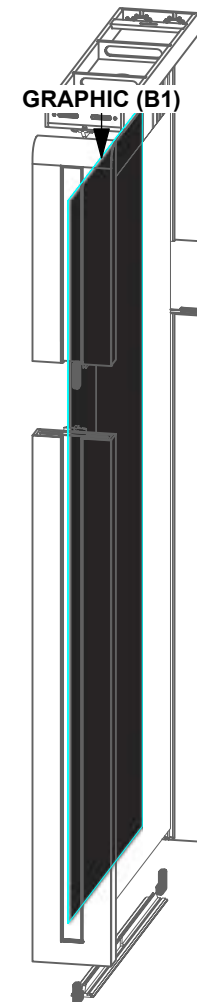
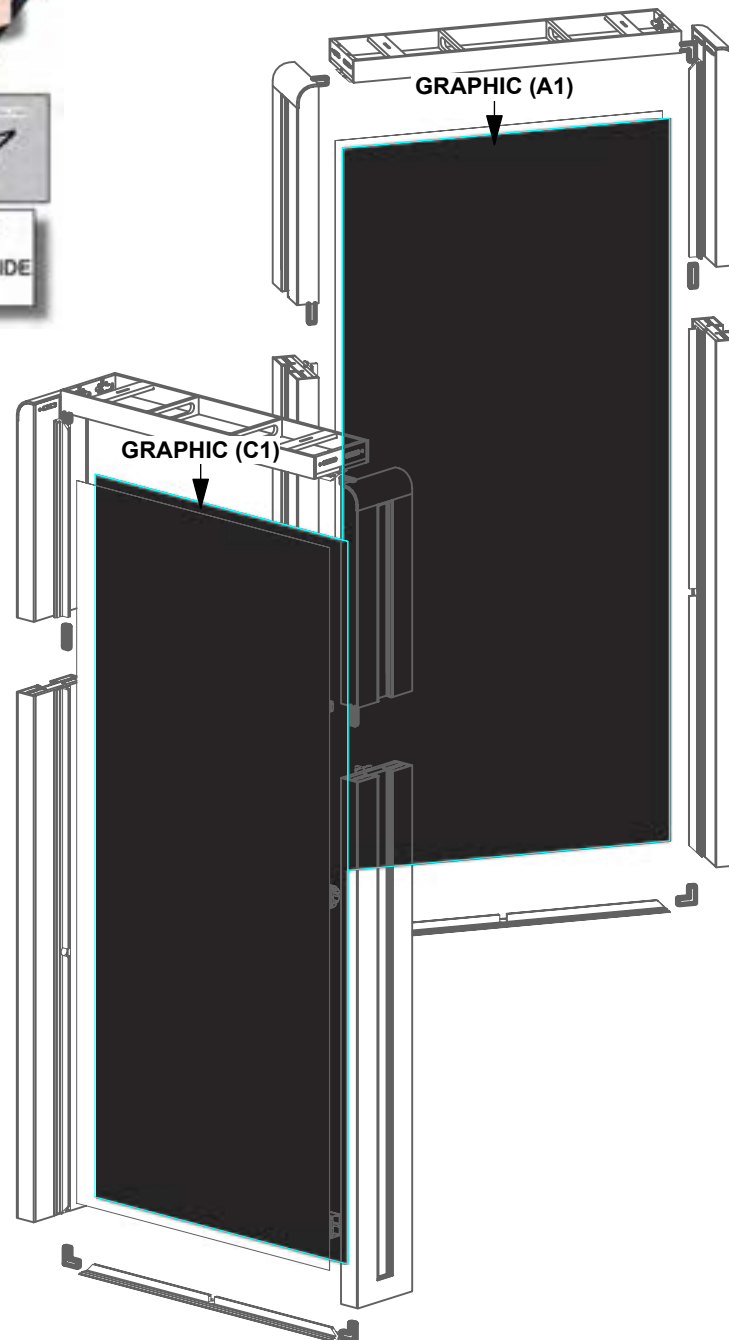
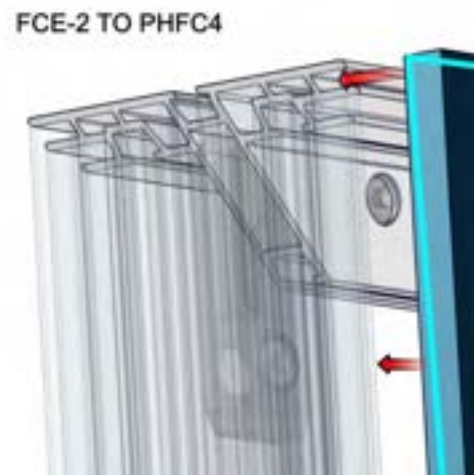

2400mm = (94 1/2")
2100mm = (82 5/8")
1800mm = (70 7/8")
1500mm = (59")
1200mm = (47 1/4")
900mm = (35 1/2")
600mm = (23 5/8")
300mm = (11 7/8")

Phone Line / Fax
Internet connection
Outlet
Main Drop (point of distribution)
Wire running under carpet

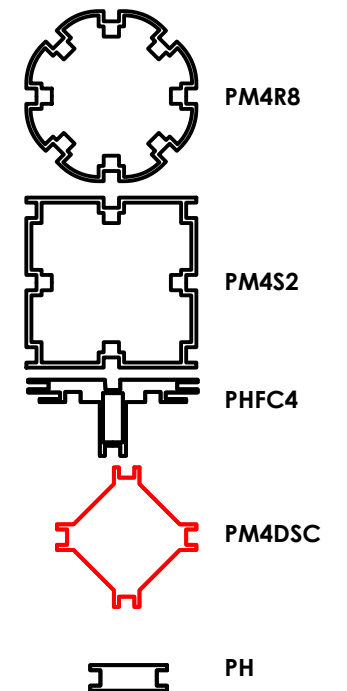

Code	#	Description
EXT-LG-MB	3	Large LCD Monitor mount, 37" - 70" size, 110 Lb. max. weight, Tilting-with extrusion mounted hardware
GRAPHIC (F1)	1	(7.82 w X 129.87 h total size) 3.82 w X 125.87 h finish size, UV/LED print on Backlit Intensity, single sided, sewn with silicone bea
GRAPHIC (F2)	1	(7.82 w X 129.87 h total size) 3.82 w X 125.87 h finish size, UV/LED print on Backlit Intensity, single sided, sewn with silicone bea
GRAPHIC (G1)	1	(7.82 w X 129.87 h total size) 3.82 w X 125.87 h finish size, UV/LED print on Backlit Intensity, single sided, sewn with silicone bea
GRAPHIC (G2)	1	(7.82 w X 129.87 h total size) 3.82 w X 125.87 h finish size, UV/LED print on Backlit Intensity, single sided, sewn with silicone bea
GRAPHIC (H1)	1	(7.82 w X 129.87 h total size) 3.82 w X 125.87 h finish size, UV/LED print on Backlit Intensity, single sided, sewn with silicone bea
GRAPHIC (H2)	1	(7.82 w X 129.87 h total size) 3.82 w X 125.87 h finish size, UV/LED print on Backlit Intensity, single sided, sewn with silicone bea

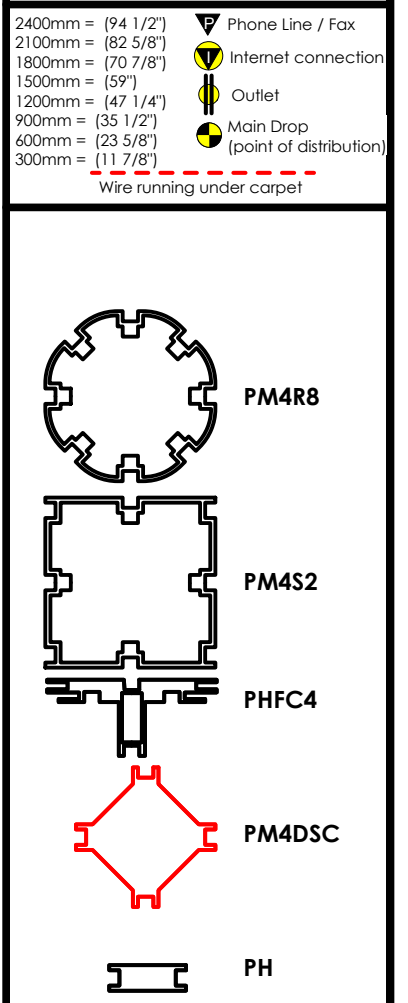
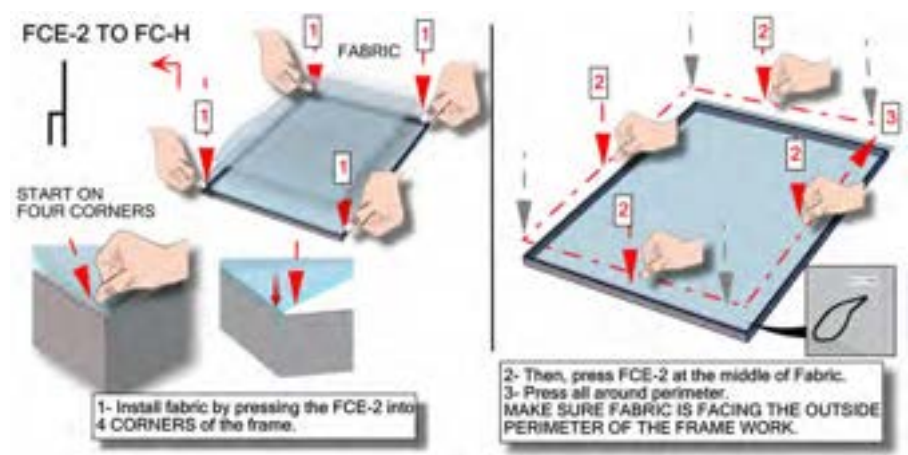
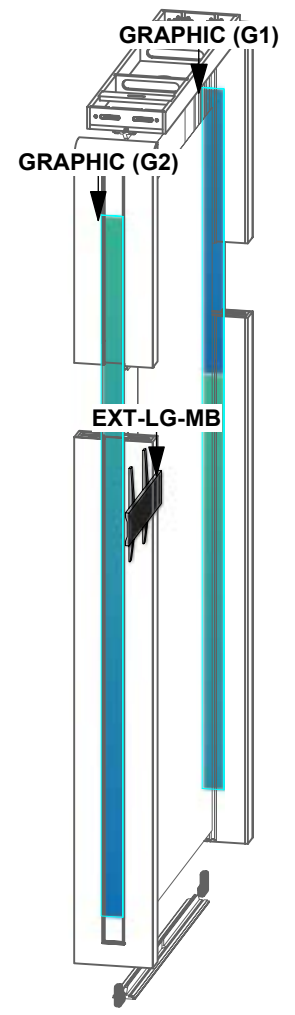
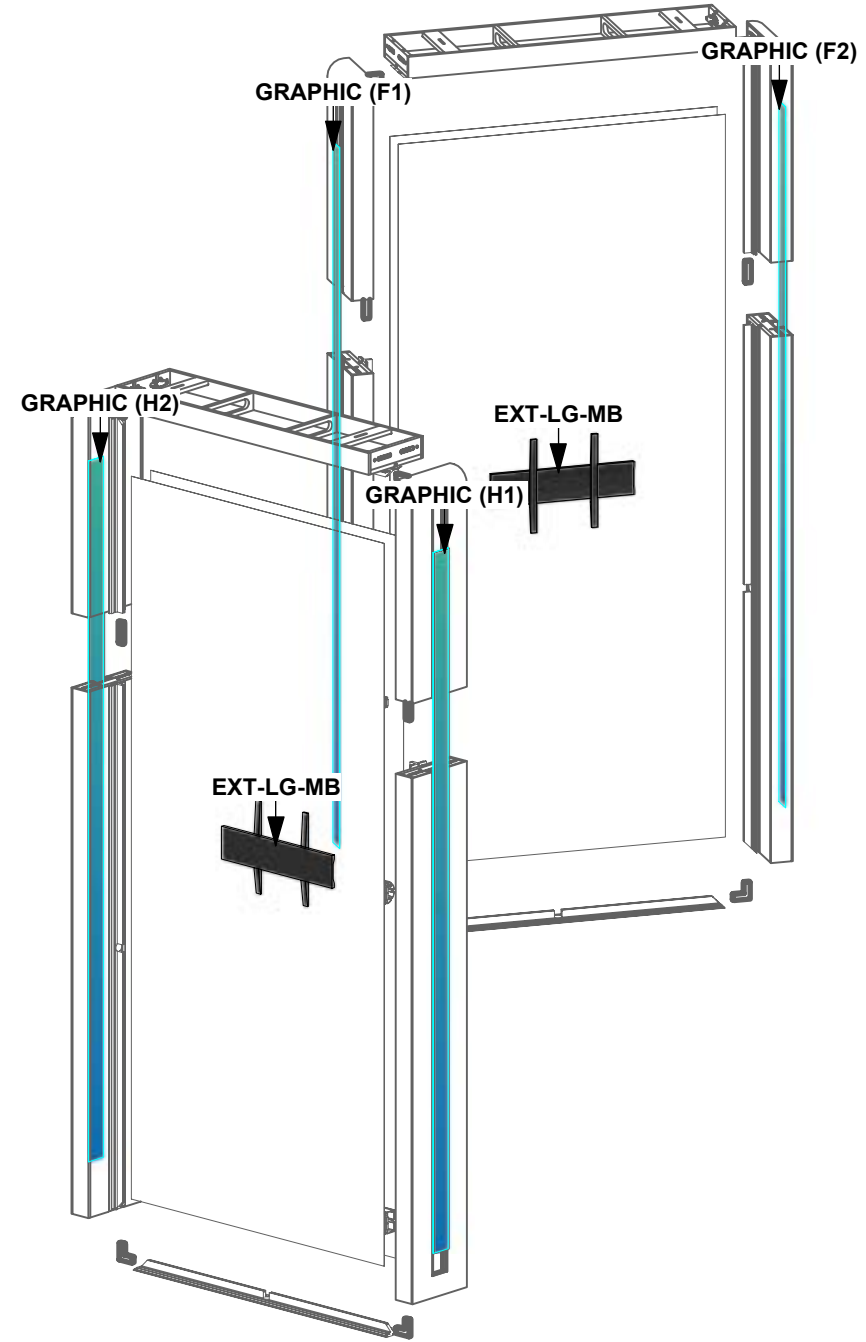
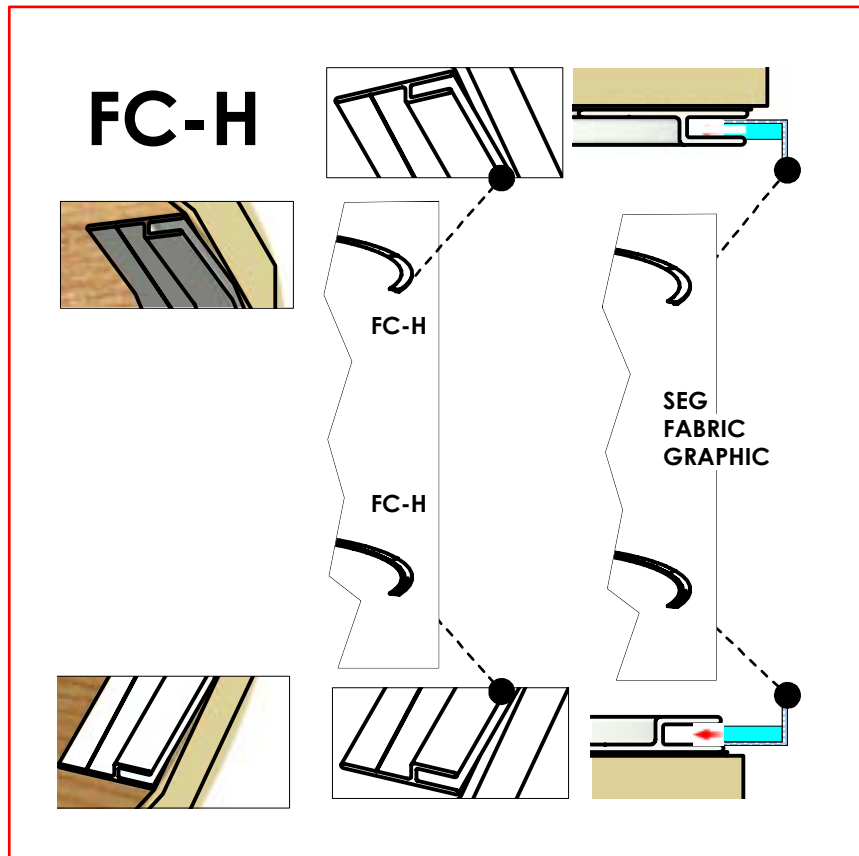

Code	#	Description
PANEL 6	1	WATERFALL COUNTER APPROX. 2' W X 5' D X 42" H, SPLITS FOR PACKING *WILSONART WHITE LAMINATE*
PANEL 7	1	WATERFALL COUNTER APPROX. 2' W X 5' D X 42" H, SPLITS FOR PACKING *WILSONART WHITE LAMINATE*
CUS-CTR-02	2	CUSTOM WOOD COUNTER W/ LOCKING DOORS AND RADIUS CORNERS, 45" W X 1' D X 41" H, W/ 3" TOEKICK, MUL

2400mm = (94 1/2") Phone Line / Fax
 2100mm = (82 5/8") Internet connection
 1800mm = (70 7/8") Outlet
 1500mm = (59")
 1200mm = (47 1/4")
 900mm = (35 1/2")
 600mm = (23 5/8") Main Drop (point of distribution)
 300mm = (11 7/8")
 Wire running under carpet

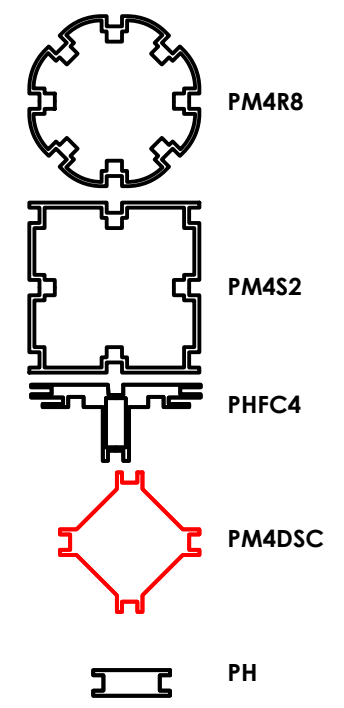
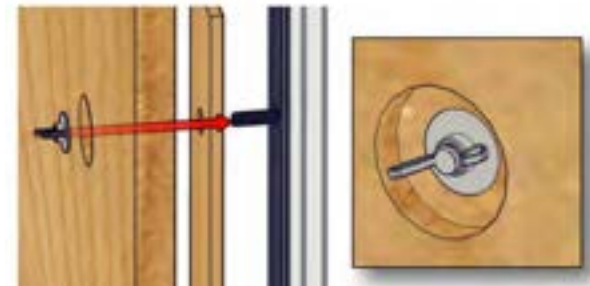
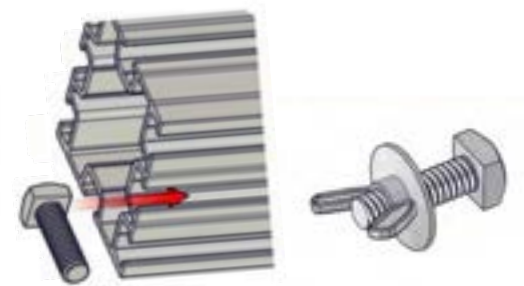
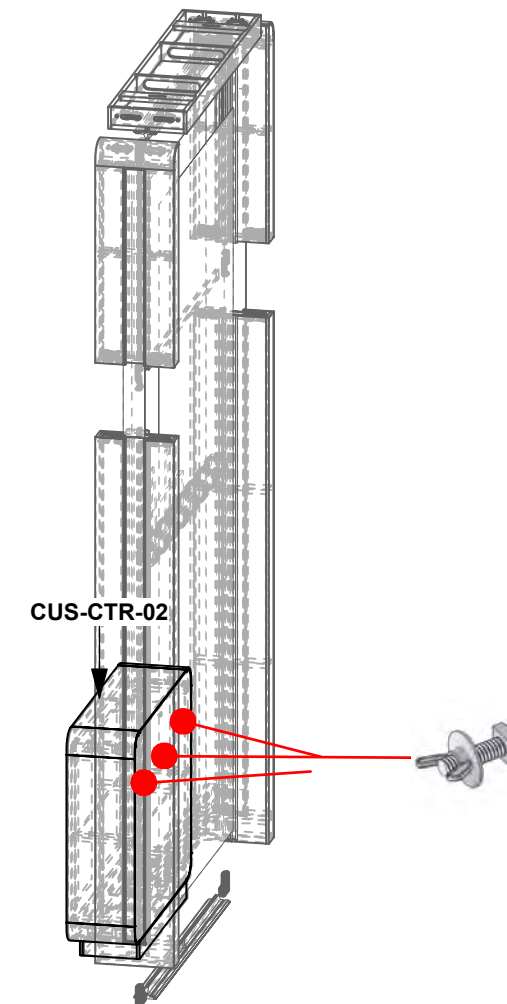
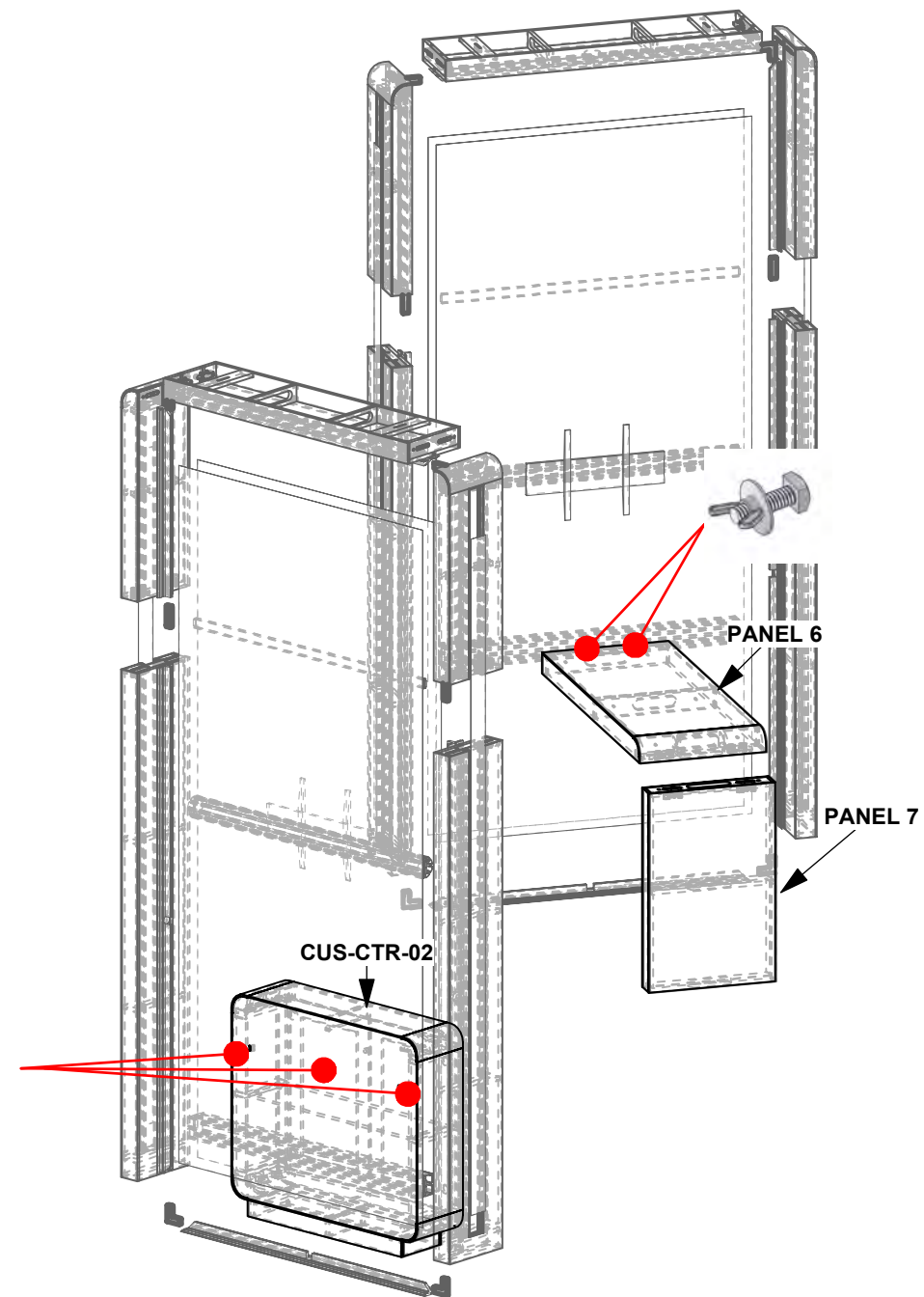

SET UP INSTRUCTIONS:

1. CONNECT BOTTOM AND TOP TUBES FOLLOWING THE LABELS
2. CONNECT SIDE TUBES
3. CLEAN THE FRAME AND PLACE THEM ON CLEAN PLACE
4. CAREFULLY REMOVE FABRIC COVER FROM BAG
5. PLACE COVER AROUND THE BOTTOM OF THE FRAME
6. PULL COVER CAREFULLY UP TO THE TOP
7. CLOSE ALL ZIPPERS
8. ADJUST FABRIC AROUND THE FRAME
9. CONNECT CABLE HARNESS TO THE EYEBOLTS
10. COMPLETELY TIGHTEN THREADED CONNECTORS

BREAK DOWN INSTRUCTIONS:

REVERSE SET-UP STEPS TO BREAKDOWN FRAME

FABRIC CARE INSTRUCTIONS:

1. UNZIP COVER ZIPPERS
2. CAREFULLY REMOVE FABRIC COVER
3. CLOSE ALL ZIPPERS
4. FOLD OR ROLL NEATLY
5. PLACE FABRIC IN COVER BAG

SET UP INSTRUCTIONS

REVISIONS				
REV.	DESCRIPTION	INITIALS	DATE	APPROVED

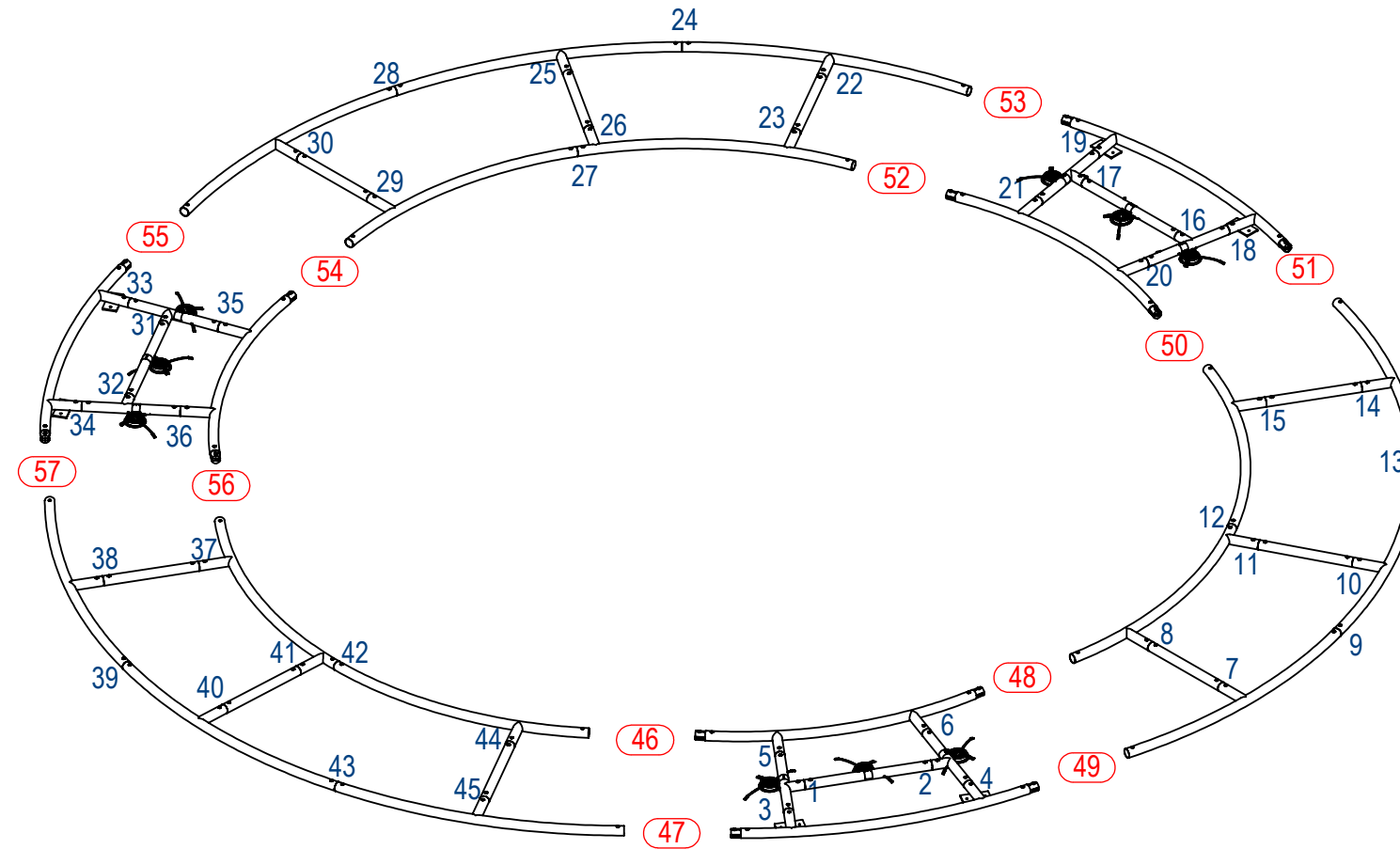

2400mm = (94 1/2")	▼ Phone Line / Fax
2100mm = (82 5/8")	▼ Internet connection
1800mm = (70 7/8")	▼ Outlet
1500mm = (59")	▼ Main Drop (point of distribution)
1200mm = (47 1/4")	▼ Wire running under carpet
900mm = (35 1/2")	
600mm = (23 5/8")	
300mm = (11 7/8")	

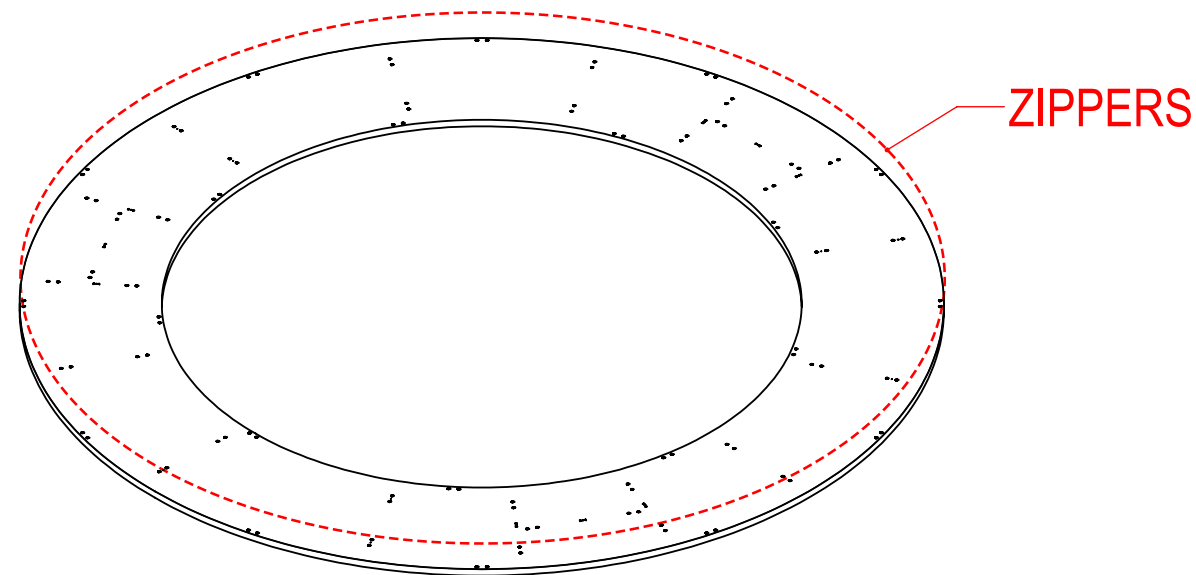
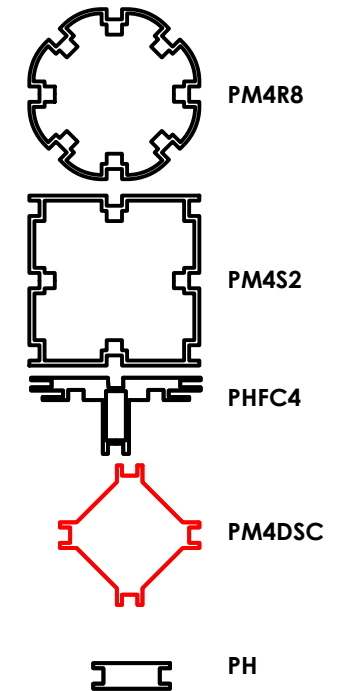

STEP 1:
TIGHTEN THE JOINT BY TIGHTENING THE HEX SCREW INTO THE HOLES IN THE HOLES ON THE TUBING

STEP 2:
TIGHTEN THE HEX SCREW SO THE JOINT SEPARATES AND THE JOINTS ARE ASSEMBLED. ALL KINDS OF JOINTS, LOCKING JOINTS AND JOINTS ARE ALLOWED.

Code	#	Description
CUS-FABSTR-	1	FLAT FORMULATE RING, SINGLE SIDED, 19.5' DIAMETER W/ 13.5' DIAMETER OPENING. 9 PU
C-G-SK-PC-G	1	GRAPHIC (D1) 4 PRINTS AT -(169.47 w X 63.72 h total size) 165.47 w X 59.72 h finish size. Custom
LUM-LED6-OR	2	12 WATT LED EXHIBITION SPOTLIGHT - FIXED ANGLE - BLACK

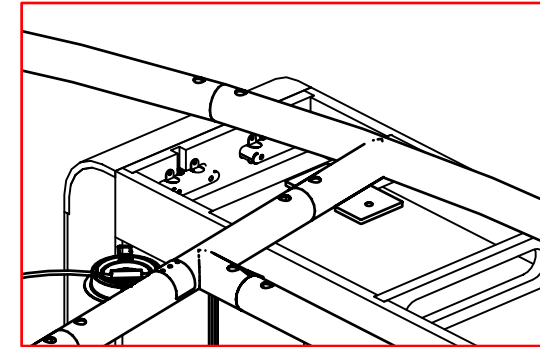

2400mm = (94 1/2")
 2100mm = (82 5/8")
 1800mm = (70 7/8")
 1500mm = (59")
 1200mm = (47 1/4")
 900mm = (35 1/2")
 600mm = (23 5/8")
 300mm = (11 7/8")

Phone Line / Fax
 Internet connection
 Outlet
 Main Drop (point of distribution)
 Wire running under carpet

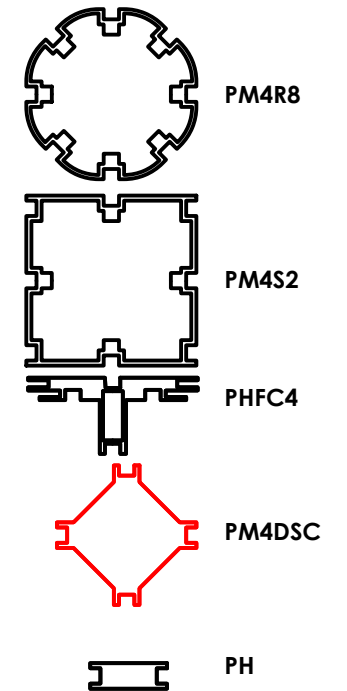
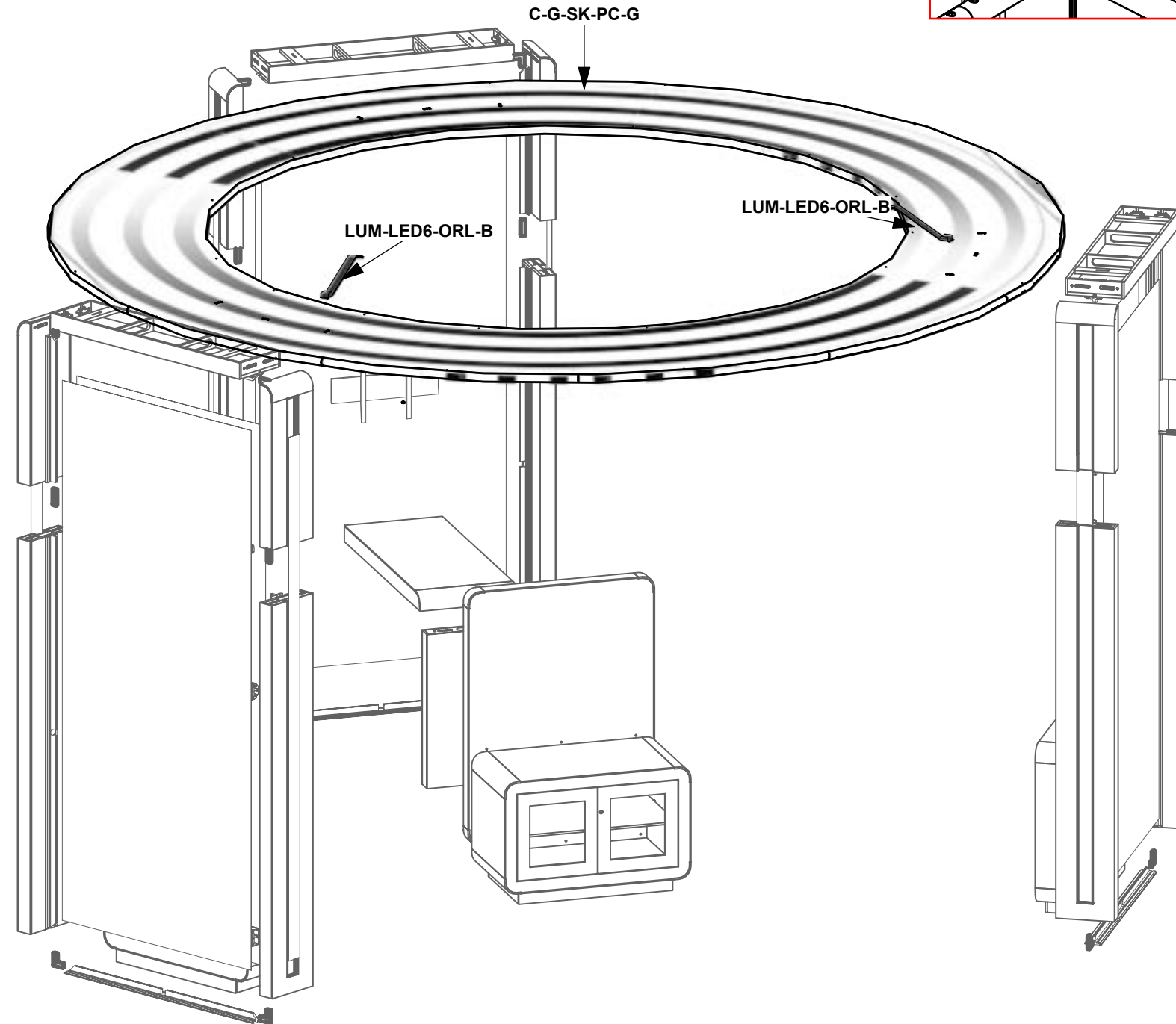

Code	#	Description
GRAPHIC (11)	1	(32.50 w X 32.50 h total size) 31.50 w X 31.50 h finish size, UV print on white adhesive backed vinyl, contour cut vinyl application (fully cut & weed
CUS-KIOSK-01	1	CUSTOM WOOD LAMINATED PANEL TO ATTACH TO BACK OF COUNTER 1, BROCHURE HOLDERS AND VINYL LOGO ON BACK *WILSON
CUS-CTR-01	1	CUSTOM COUNTER W/ CURVED CORNERS, APPROX 45" W X 30" H X 25" D, TO SUPPORT 200LB CLIENT MACHINERY. MULTI COLOR TA
ABH-01	3	3MM UNIVERSAL ACRYLIC BROCHURE HOLDER WITH (2) CKSO STAND OFFS

- 2400mm = (94 1/2")
 - 2100mm = (82 5/8")
 - 1800mm = (70 7/8")
 - 1500mm = (59")
 - 1200mm = (47 1/4")
 - 900mm = (35 1/2")
 - 600mm = (23 5/8")
 - 300mm = (11 7/8")
- ☒ Phone Line / Fax
 - ☒ Internet connection
 - ☒ Outlet
 - ☒ Main Drop (point of distribution)
 - Wire running under carpet

