



Electrical



**Key**

 **10 AMP**

 **Extension w/  
power strip**

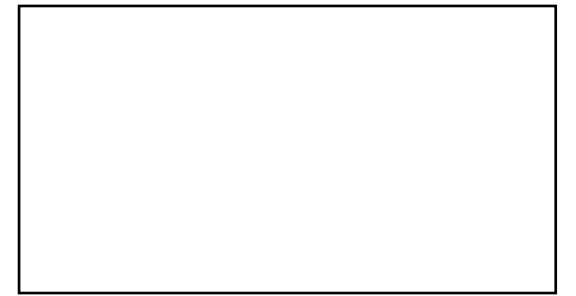
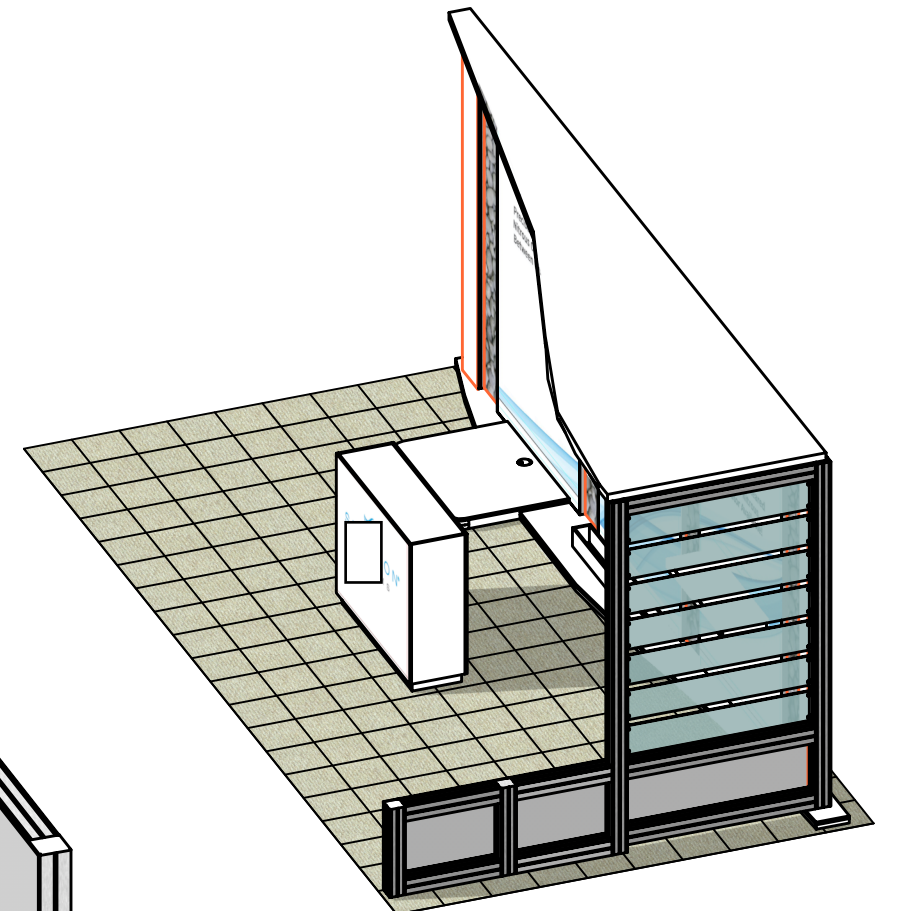
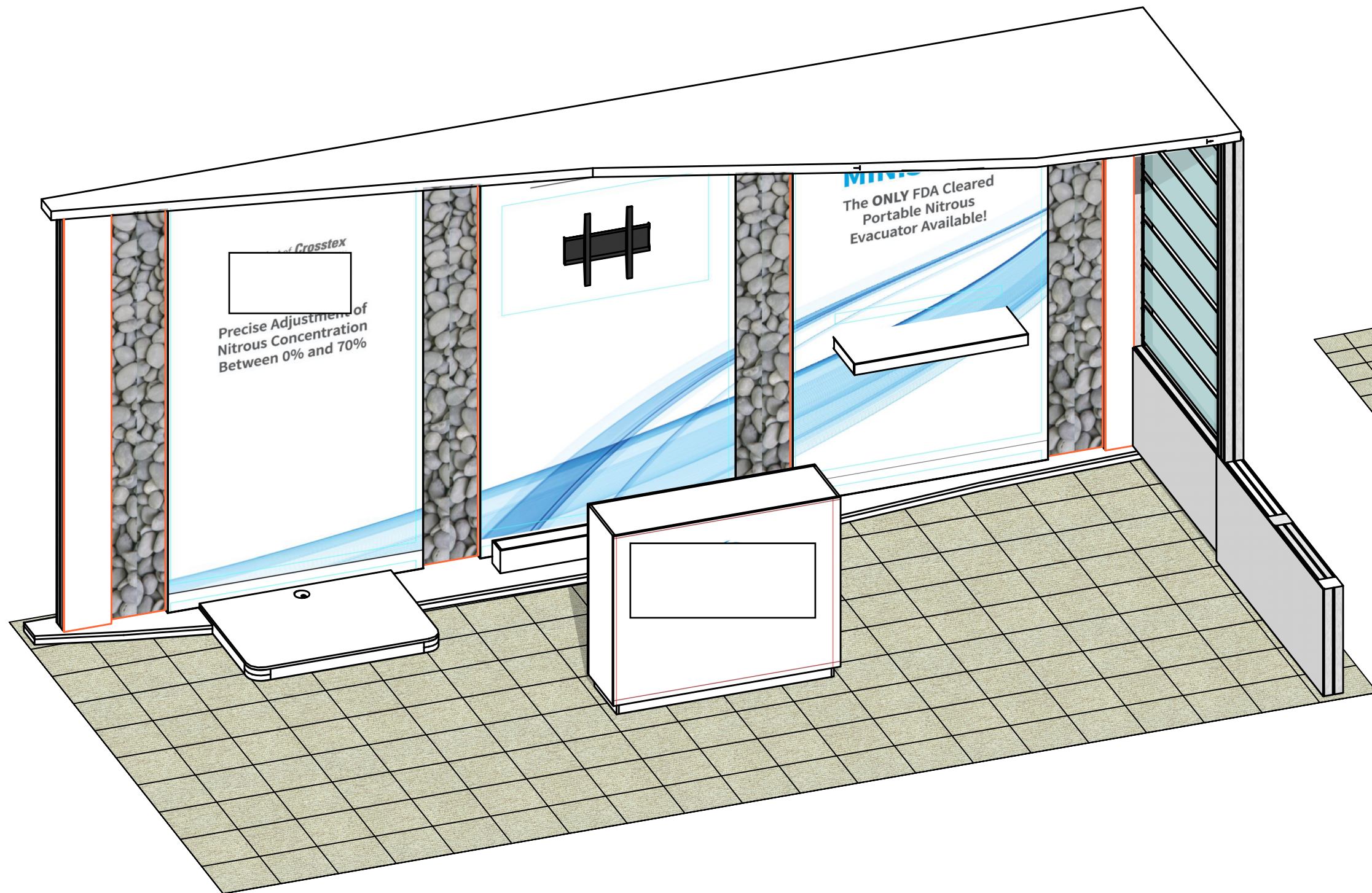

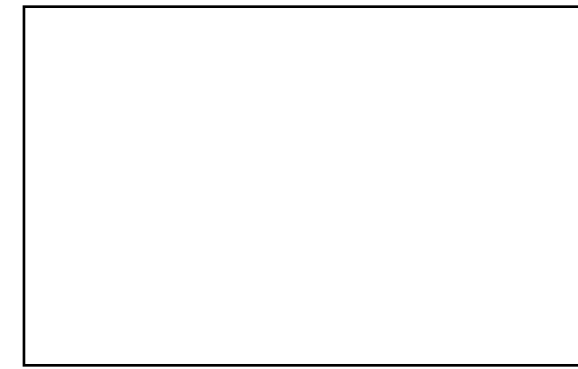

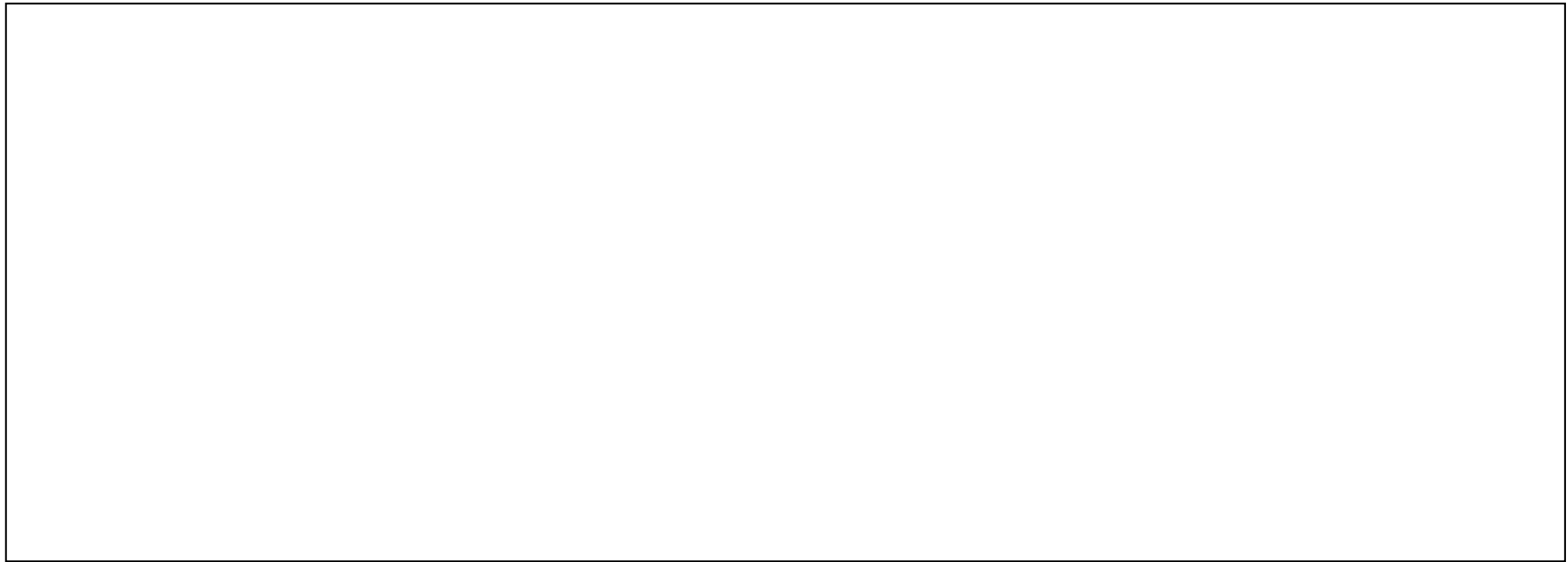

**IMPERIAL TO METRIC SIZES**

**8' Nominal = 94 1/2" or 2400mm Actual**  
**4' Nominal = 47 1/4" or 1200mm Actual**  
**3' Nominal = 35 7/16" or 900mm Actual**  
**2' Nominal = 23 5/8" or 600mm Actual**  
**1' Nominal = 11 13/16" or 300mm Actual**



# FABRIC, VINYL & UV GRAPHIC CARE GUIDELINES

## GENERAL HANDLING FABRIC GRAPHICS

- Your fabric graphics should always be handled in a clean, dry area with clean hands. When possible, use white fabric gloves.
- Be sure fabric is clean and dry before packing.
- Machine washing and/or drying is not recommended for all fabrics. Refer to chart below for which fabrics are washable.

## EMERGENCY STAIN TREATMENT (FABRIC)

- For dry stains, like loose dirt or pencil marks, try initially using masking tape or Magic Eraser (dry-not moistened).
  - Masking tape or MagicEraser (dry) can be quite effective at lifting dry, surface dirt. Try 'pulling' as much of stain away as you can. Avoid rubbing stain into fabric.
- Introduce water or liquid cleaner for stains not responsive to masking tape or dry Magic Eraser.
  - When using liquids to treat stains, if at all possible, treat the stain with fabric off of the frame.
  - Place a clean dry cloth behind stain (to absorb stain while being treated). Moisten another cloth initially with just water (distilled water is optimal, if available).
  - Gently blot stain with moistened cloth (or small area of moistened Magic Eraser), while trying to push stain through to the back, using the dry cloth to absorb.
  - Repeat using care to keep the wet area as small as possible.
- Grandma's Secret Spot Remover can be an effective stain remover. Mix several drops in a small cup with clean water. Repeat above technique, taking care to keep wet area as small as possible and using dry cloth on back of stain to absorb.

## MACHINE WASHING FABRIC GRAPHICS

- Cold water/delicate cycle/tumble dry low or air dry. For stretch fabrics do not use dryer, let hang dry.
- Use caution on dryer time with graphics containing liners. Its best to put tension fabric on frame when fabric is still damp and let it air dry. Always be sure that the aluminum frame is clean when mounting the damp graphic.
- Fabric stretch graphics that are washed and machine dried may shrink up to 3/4" per every 50" of fabric in the direction of the stretch and shrink up to 1/4" in the non stretch direction.

## STORING & PACKING BACKLIT GRAPHICS

- To avoid cracks in the ink or having to steam graphics, Backlit fabrics should be loosely folded with bubble wrap or stored around a tube.
- Avoid folding the graphic tightly to store in a small bag or box.

## GENERAL HANDLING VINYL & UV GRAPHICS

- Vinyl banners and rigid graphics should always be handled in a clean, dry area with clean hands. When possible, use white fabric gloves.
- Be sure vinyl/ UV is clean and dry before packing. Always follow material handling and packing instructions included.
- All vinyl materials should be rolled with graphics facing in to protect the graphic printed side. Roll on a tube if available.
- Avoid folding materials to reduce the risk of crease lines and chipped inks. If a graphic must be folded, try to fold loosely and as few times as possible.

## EMERGENCY STAIN TREATMENT (UV)

- For drier stains, like loose dirt, pencil marks or adhesive, try initially using masking tape. Masking tape can be quite effective at lifting dry, surface dirt. Try 'pulling' as much of stain away as you can and avoid rubbing the stain into the material.
- When using Solvent to clean a stain be sure to avoid any image. Solvent is aggressive and will take the image off. Soapy water should be used at a ratio of 1 part Dawn® /10 parts water.
- While using Windex® avoid scrubbing harshly. Too much pressure can fade the graphic print.

## GENERAL HANDLING OF ROLLABLE PVC PANELS

All mural panels, truss panels and detachables should be rolled with graphics facing out to protect the graphic printed side. Mural panels should be stored in the original plastic sleeves that are provided with the panels.

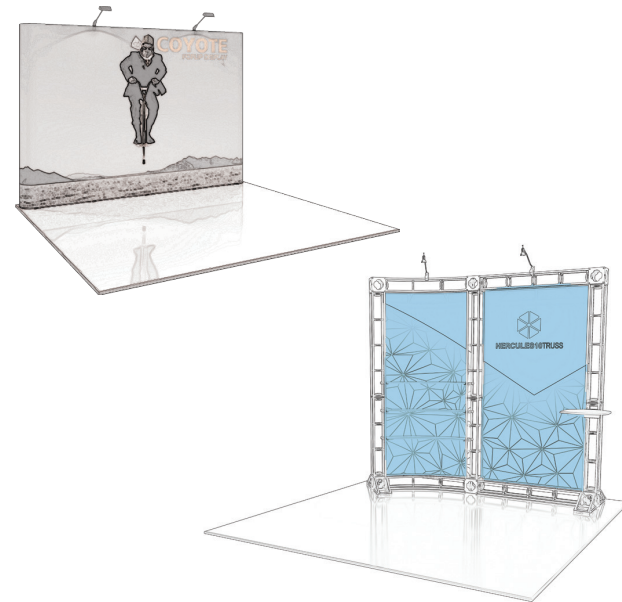

# FABRIC, VINYL & UV GRAPHIC CARE GUIDELINES

## STEAMING FABRIC GRAPHICS

- For optimal results, steam wrinkles when fabric is tensioned and installed securely on the frame.
- Fill steamer with clean drinking water or distilled water. Avoid using water containing hard minerals.
- Hold steamer upright and hold close to fabric. Avoid touching fabric with steamer.
- Do not tip steamer as water drips may cause water marks to form on graphic.

### NON BACKLIT FABRIC

\* IF WRINKLES APPEAR

-STEAM FABRIC FROM THE FRONT SIDE OF THE FABRIC.

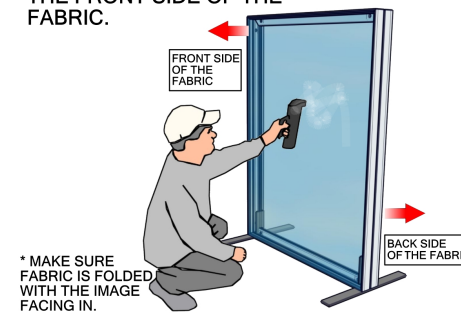

### BACKLIT FABRIC

\* IF WRINKLES APPEAR

1-STEAM FABRIC FROM THE BACK SIDE OF THE FABRIC WHEN POSSIBLE.

2-STEAM FABRIC FROM THE FRONT SIDE OF THE FABRIC WHEN ACCESS TO BACK SIDE IS NOT AN OPTION

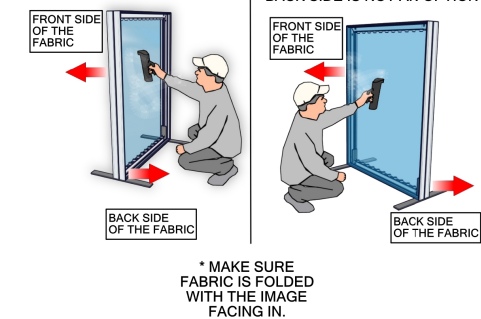

## HANDLING REFERENCE CHART

FABRIC	WASHING MACHINE	DRY CLEAN	SPOT CLEAN	STEAMING/ IRON	MAGIC ERASER
RESILIENCE	NO	NO	NO	NO	YES (ONLY ON WHITE)
OXFORD	YES	YES	YES	YES	YES
POWER STRETCH	YES	YES	YES	YES	YES
DISPLAY POLYESTER	YES	YES	YES	YES	YES
DISPLAY POLY CONVERTIBLES TABLE THROWS	YES (MUST VELCRO THE TABS)	YES (MUST VELCRO THE TABS)	YES	YES	YES
OUTDOOR FLAG	YES	N/A	YES	YES	YES
CANVAS OUTDOOR	NO	NO	YES	STEAM ONLY	YES
CANVAS LIGHTBOX	NO	NO	NO	STEAM ONLY	YES
AGILITY	YES	YES	YES	(ONLY W/ 100% TENSION)	YES
SUPER STRETCH	YES	YES	YES	(ONLY W/ 100% TENSION)	YES
TRIPLE WHITE	YES	YES	NO	YES	NO
SOFT KNIT	YES	YES	YES	YES	YES
SHEER	YES	YES	YES	YES	YES

## VINYL & ROLLABLE

	SOLVENT	SOAPY WATER (DAWN®)	WINDEX®
FLATMAXX	ONLY ON WHITE	YES	NO
SCRIM 130Z/ 180Z	ONLY ON WHITE	YES	NO
VINYL 200Z	ONLY ON WHITE	YES	NO
MELINEX	NO	YES	NO
MURAL PANELS	NO	YES	YES
UV RIDGED	NO	YES	YES



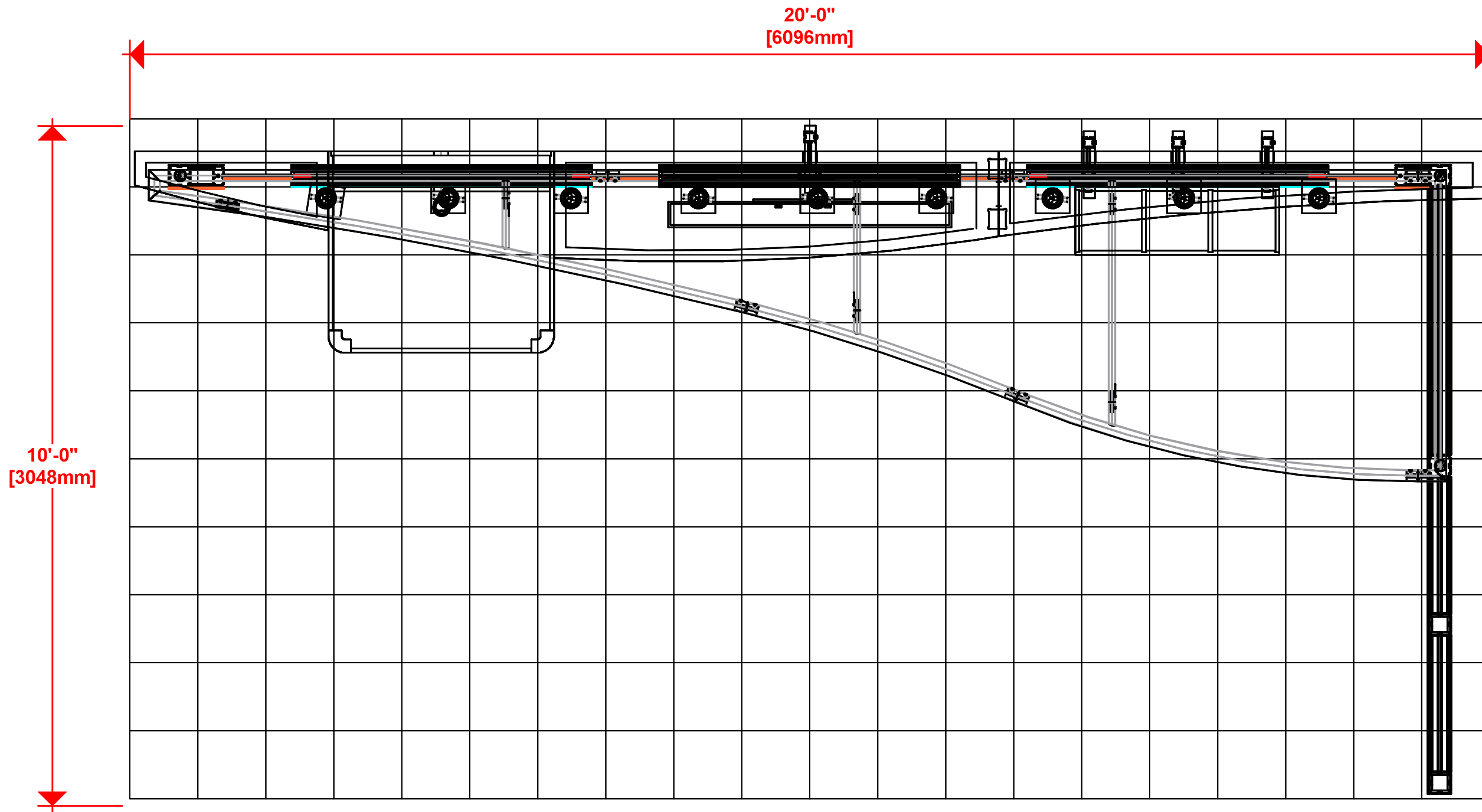

- 2400mm = (94 1/2")
  - 2100mm = (82 5/8")
  - 1800mm = (70 7/8")
  - 1500mm = (59")
  - 1200mm = (47 1/4")
  - 900mm = (35 1/2")
  - 600mm = (23 5/8")
  - 300mm = (11 7/8")
- ▼ Phone Line / Fax
  - ▼ Internet connection
  - Outlet
  - Main Drop (point of distrution)
  - Wire running under carpet

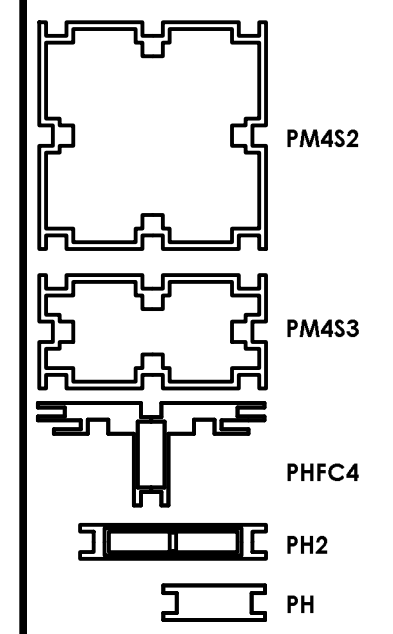

Code	#	Description
A9	2	2349MM CUT DOWN FROM 2100MM LENGTH OF PM4S2 EXTRUSION-WITH STOP AT 315MM-WITH NUT INSERT
A10	2	2349MM CUT DOWN FROM 2100MM LENGTH OF PM4S3 EXTRUSION-WITH STOP AT 315MM-WITH STOP AT 315MM
GROMMET-CAP-RNG-WHT	1	WHITE CAP & RING FOR 2 1/2" GROMMET
PANEL 2	1	**CNC** 40" X 35.58" 3" Thick Laminate wood Base-with gomet and wire management **WILSONART DESIGNER WHITE**
PANEL 4	1	**CNC** 14.3" X 85.55" 2" Thick Laminate wood Base with "T" nut for PM4S2 attachment-NOTCH ON BOTTOM FOR CUS-S
PANEL 1	1	**CNC** 12.8" X 34.06" 2" Thick Laminate wood Base with "T" nut for PM4S2 attachment **WILSONART DESIGNER WHITE**
PANEL 3	1	**CNC** 14.3" X 78.38" 2" Thick Laminate wood Base**WILSONART DESIGNER WHITE**

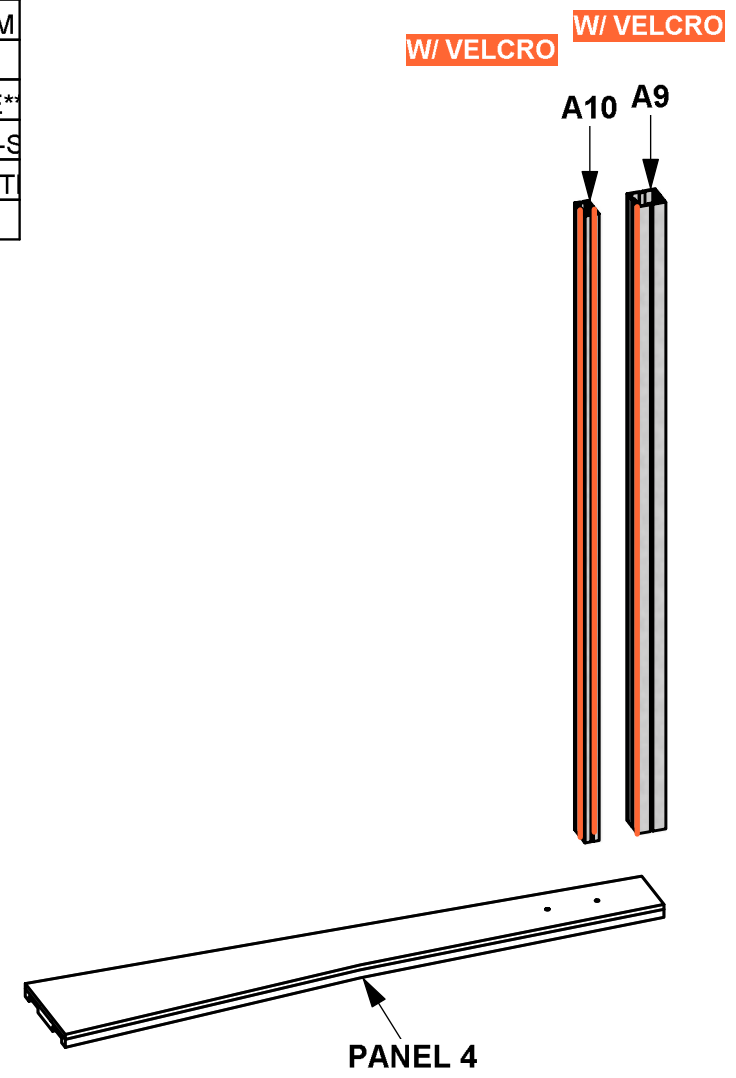
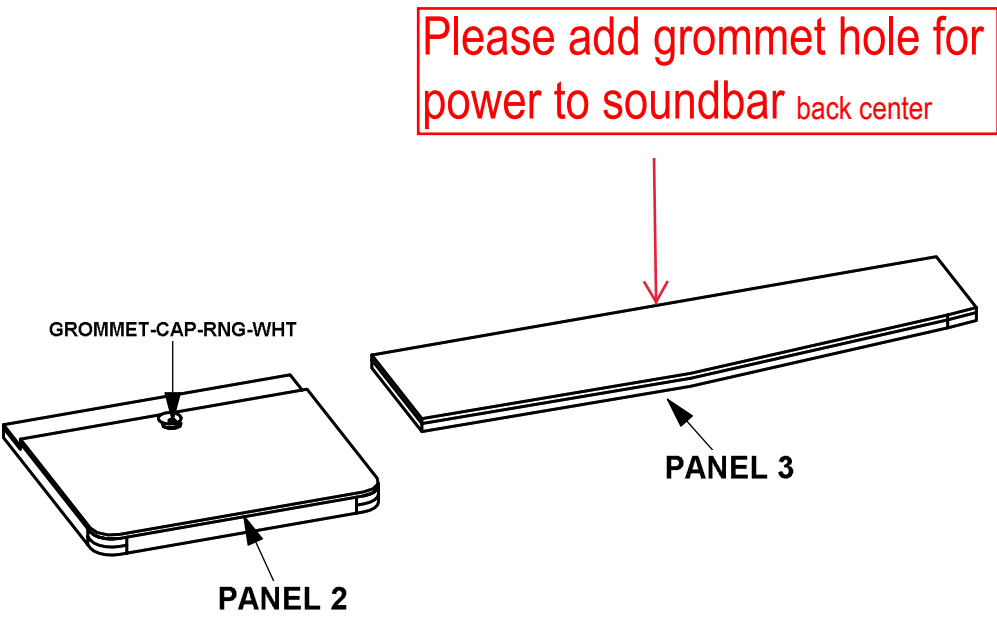
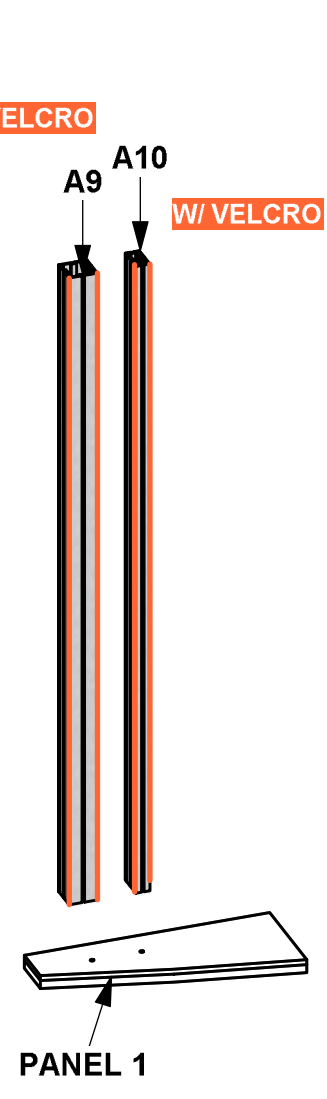
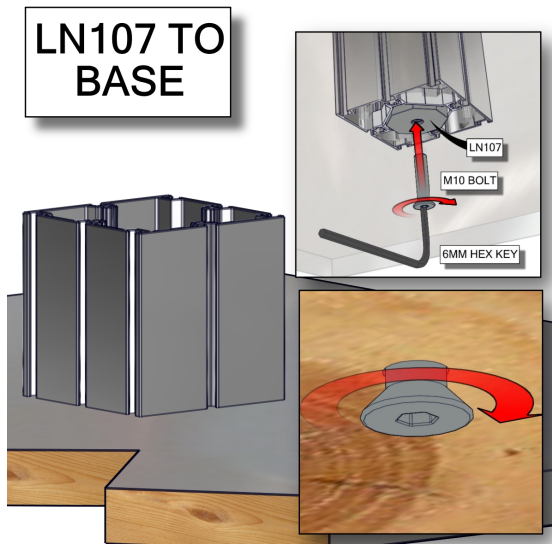
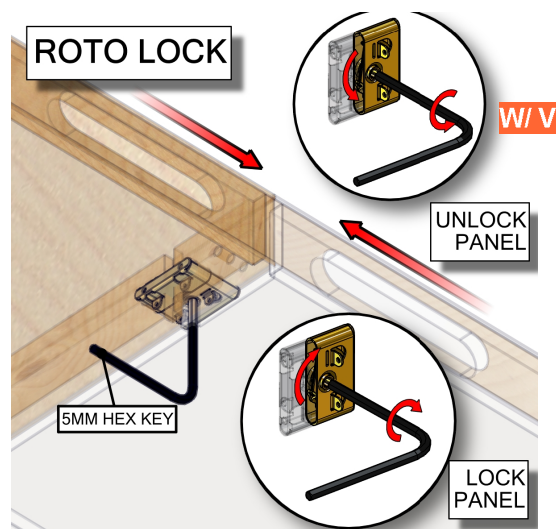

- 2400mm = (94 1/2")
  - 2100mm = (82 5/8")
  - 1800mm = (70 7/8")
  - 1500mm = (59")
  - 1200mm = (47 1/4")
  - 900mm = (35 1/2")
  - 600mm = (23 5/8")
  - 300mm = (11 7/8")
- Phone Line / Fax
  - Internet connection
  - Outlet
  - Main Drop (point of distrution)
  - Wire running under carpet

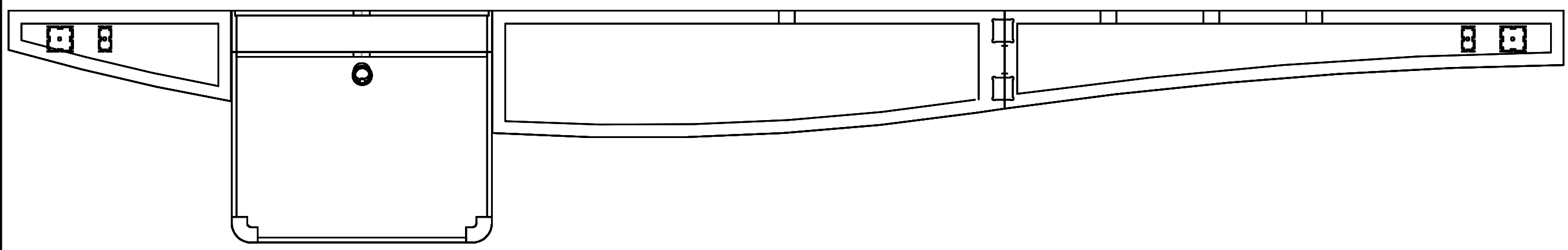
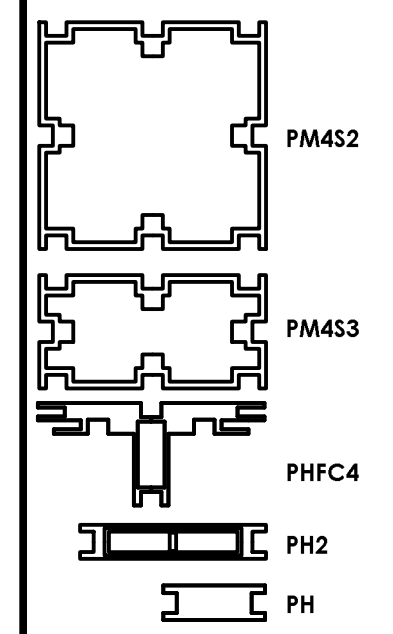

Code	#	Description
A6	2	1350MM CUT DOWN FROM 1500MM LENGTH OF PHFC4 EXTRUSION-WITH MITRE CUT FOR CB9-WITH MITRE CUT FOR CB9
CB9	4	90 DEGREE JOINER
A7	2	2349MM CUT DOWN FROM 2400MM LENGTH OF PHFC4 EXTRUSION-WITH MITRE CUT FOR CB9-WITH MITRE CUT FOR CB9

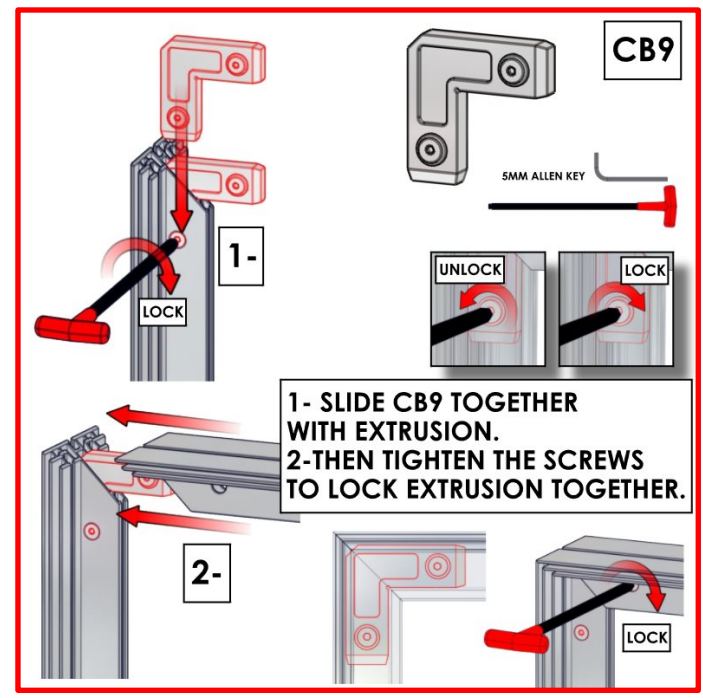
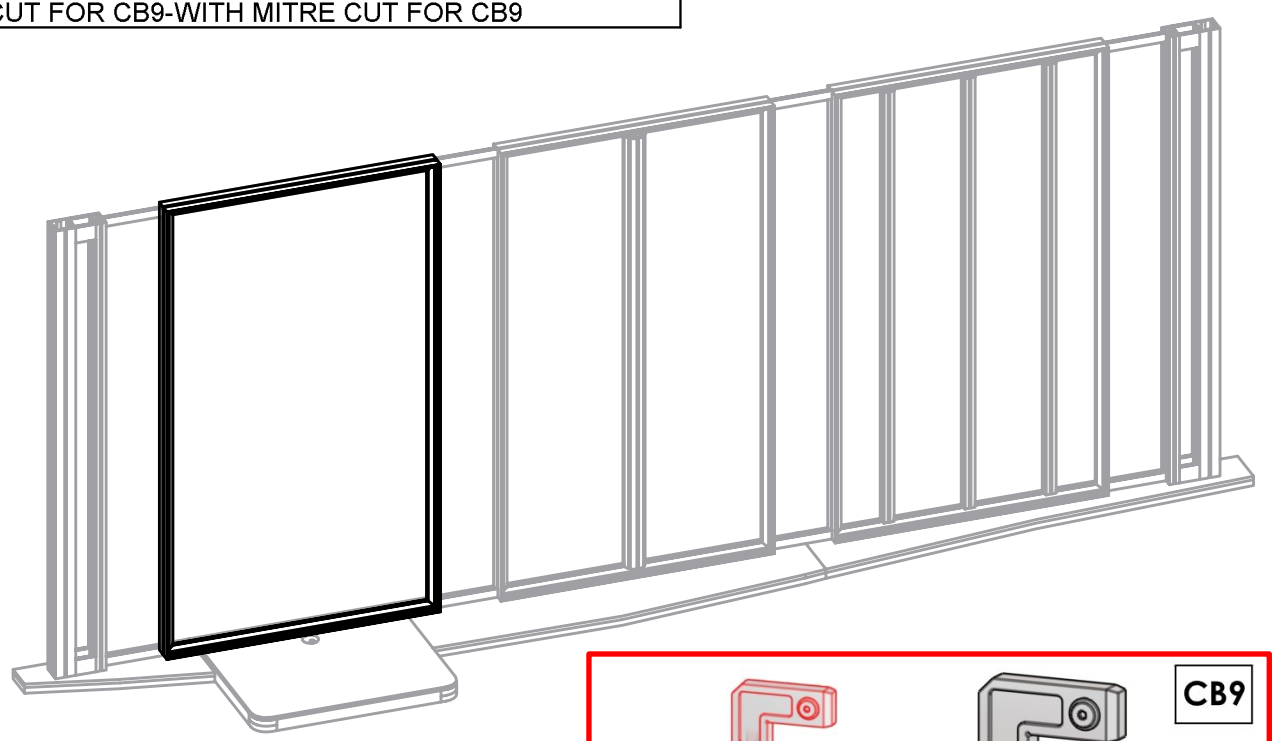
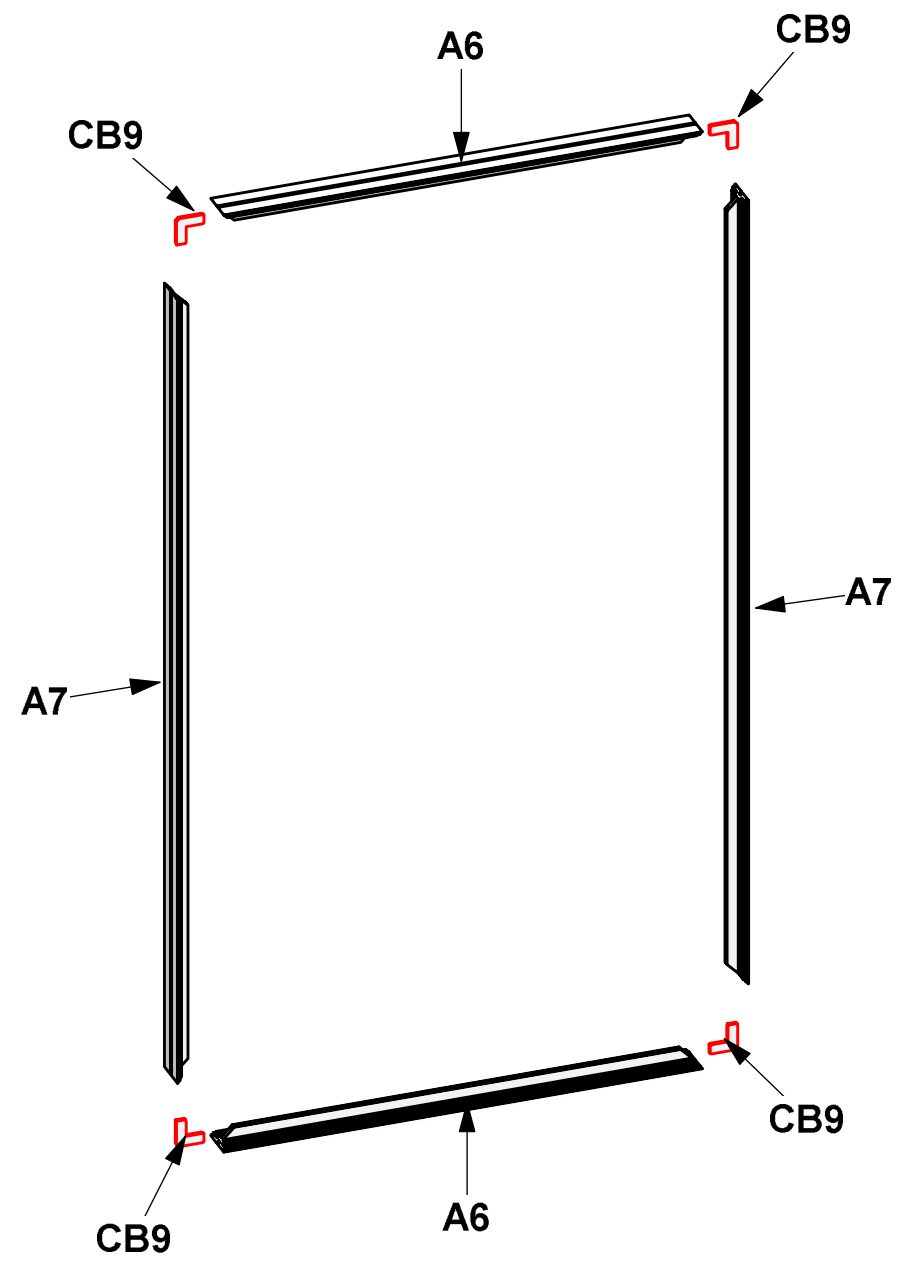

- 2400mm = (94 1/2") Phone Line / Fax
  - 2100mm = (82 5/8") Internet connection
  - 1800mm = (70 7/8") Outlet
  - 1500mm = (59") Main Drop (point of distrution)
  - 1200mm = (47 1/4")
  - 900mm = (35 1/2")
  - 600mm = (23 5/8")
  - 300mm = (11 7/8")
- Wire running under carpet

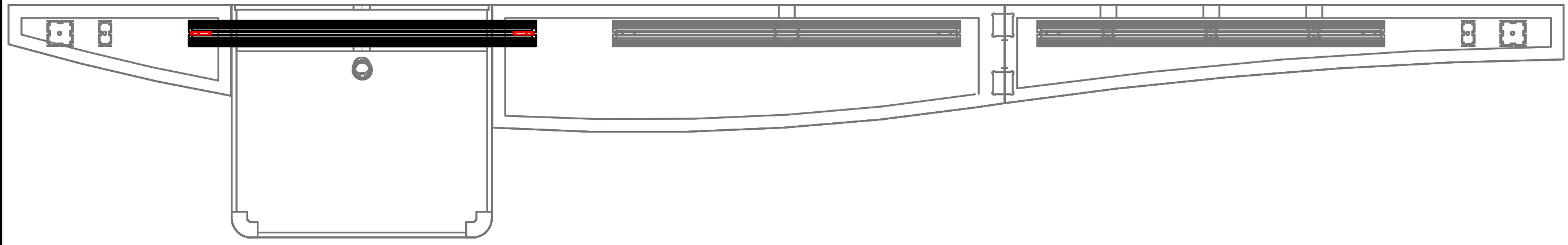
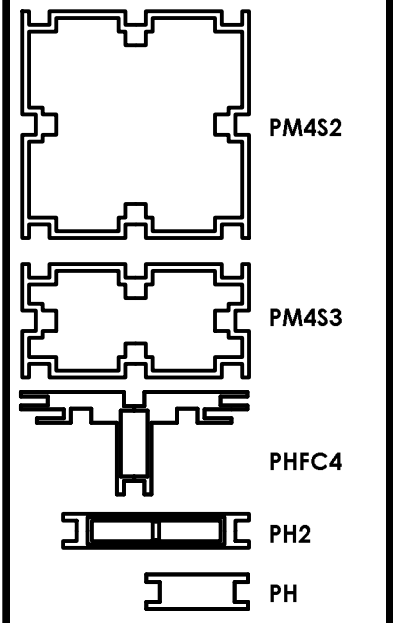



Code	#	Description
A6	2	1350MM CUT DOWN FROM 1500MM LENGTH OF PHFC4 EXTRUSION-WITH MIT
CB9	4	90 DEGREE JOINER
A7	2	2349MM CUT DOWN FROM 2400MM LENGTH OF PHFC4 EXTRUSION-WITH MIT
A12	1	2259MM CUT DOWN FROM 2100MM LENGTH OF PM4R8 EXTRUSION-WITH CAM

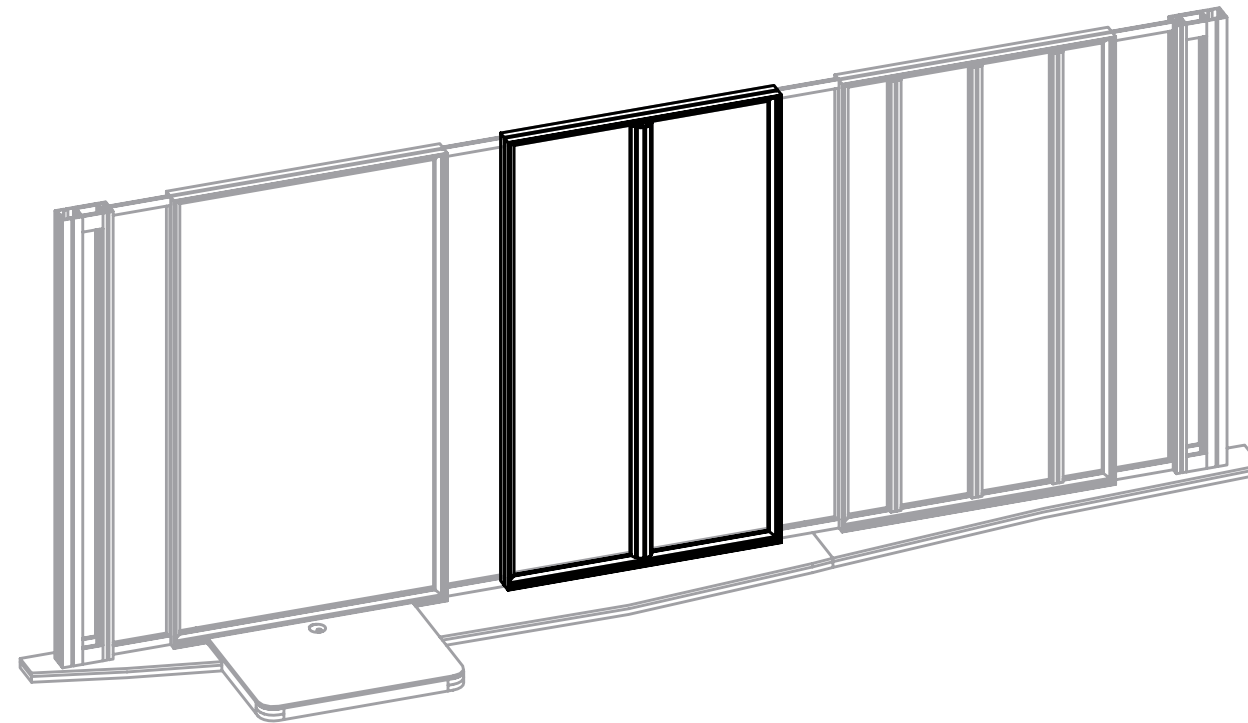
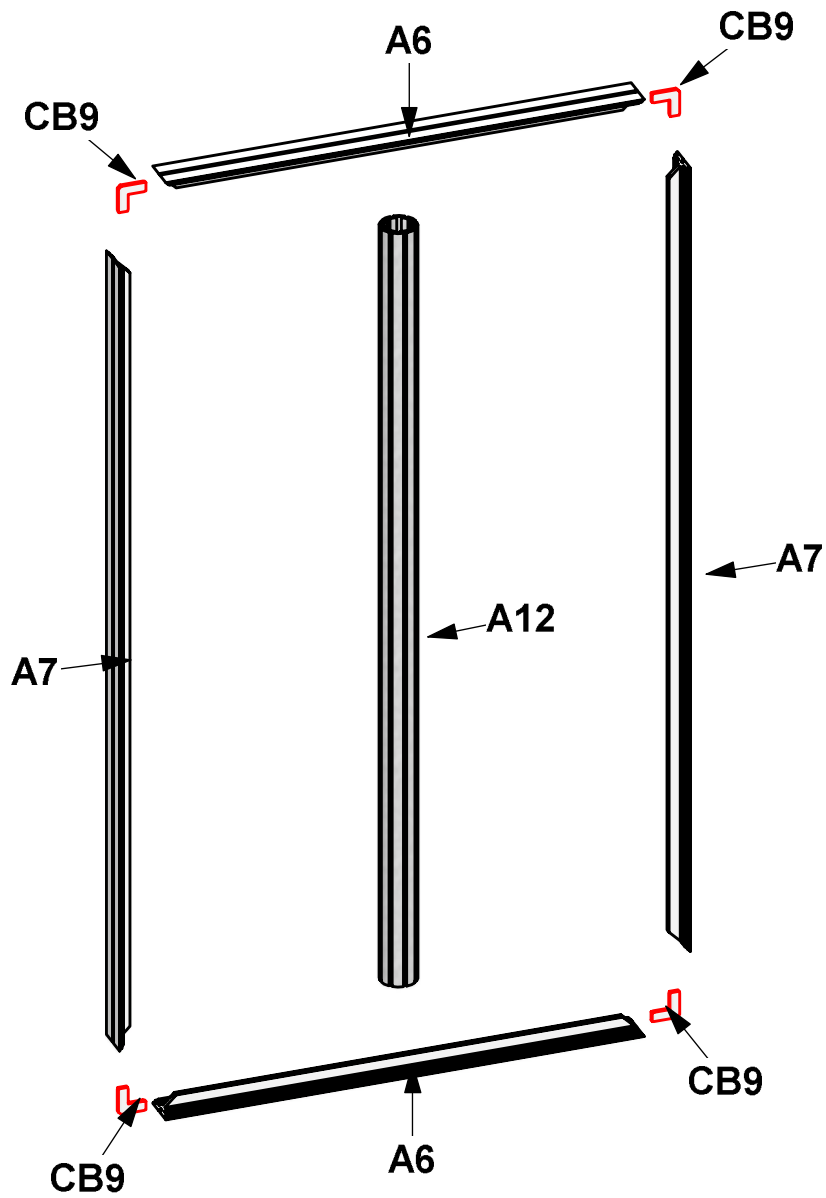

- 2400mm = (94 1/2") Phone Line / Fax
  - 2100mm = (82 5/8") Internet connection
  - 1800mm = (70 7/8") Outlet
  - 1500mm = (59") Main Drop (point of distrution)
  - 1200mm = (47 1/4")
  - 900mm = (35 1/2")
  - 600mm = (23 5/8")
  - 300mm = (11 7/8")
- Wire running under carpet

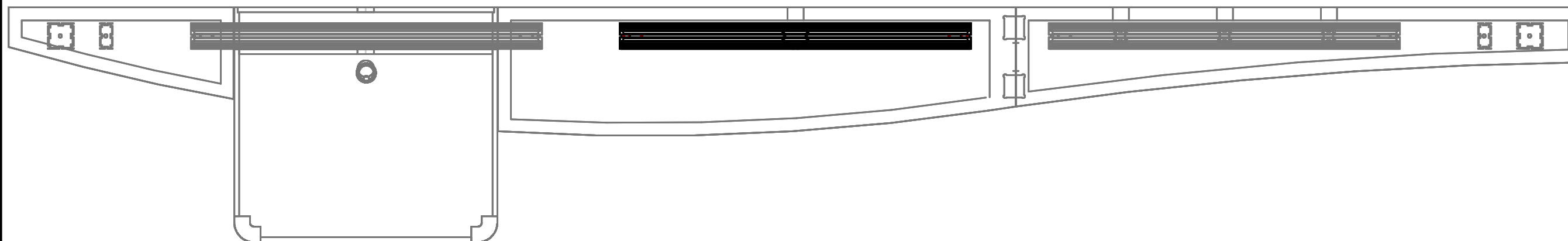
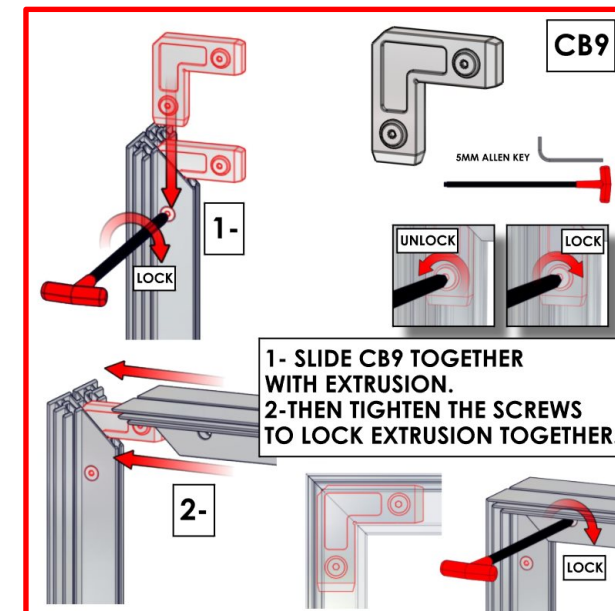
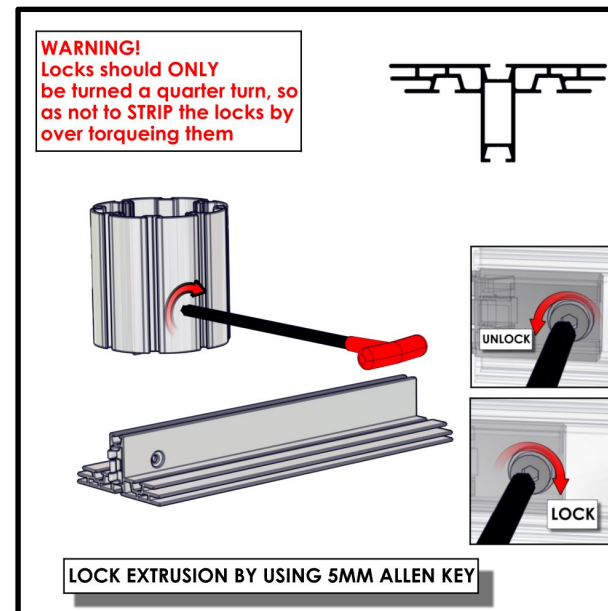
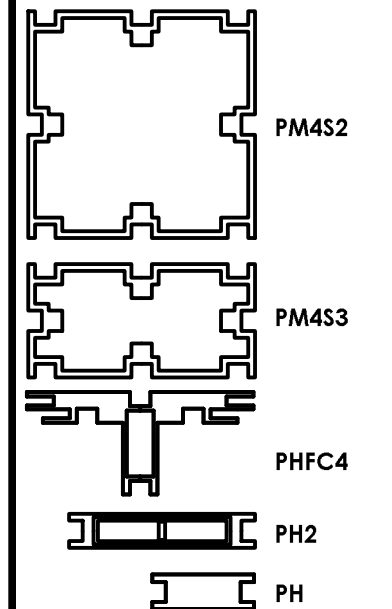

Code	#	Description
A14	3	2259MM CUT DOWN FROM 2100MM LENGTH OF PM2S2 EXTRUSION-WITH C
A6	2	1350MM CUT DOWN FROM 1500MM LENGTH OF PHFC4 EXTRUSION-WITH M
CB9	4	90 DEGREE JOINER
A7	2	2349MM CUT DOWN FROM 2400MM LENGTH OF PHFC4 EXTRUSION-WITH M

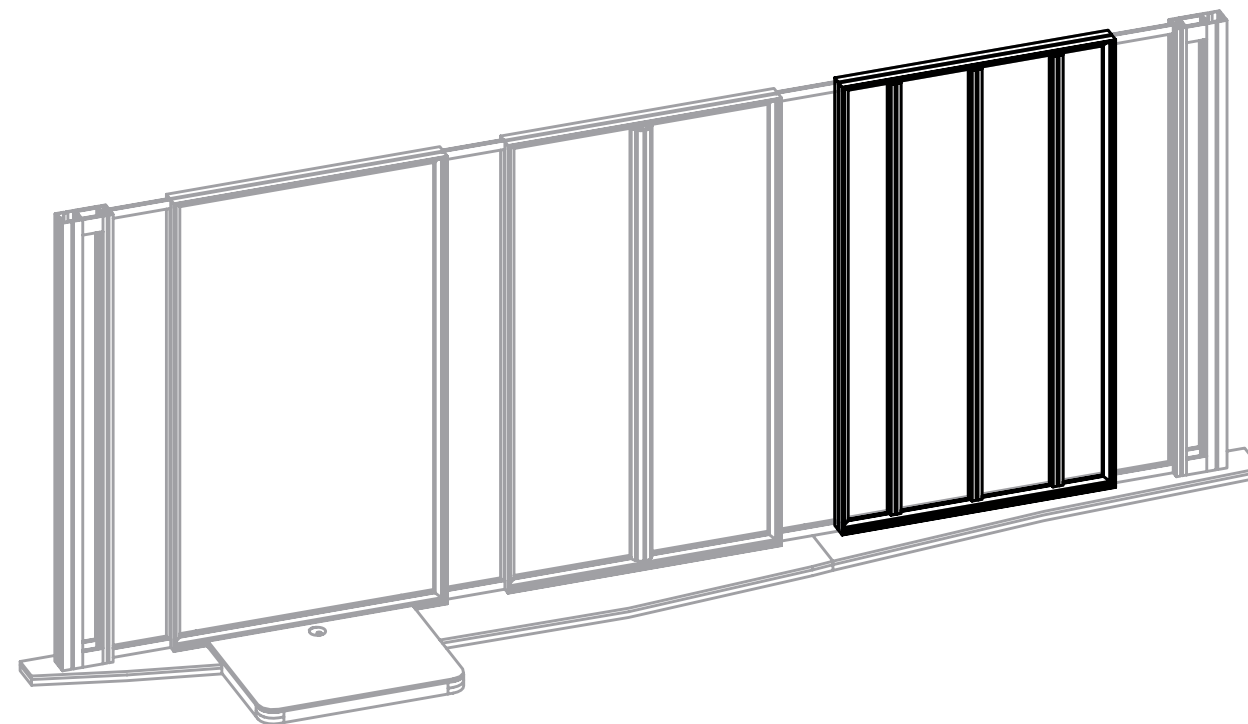
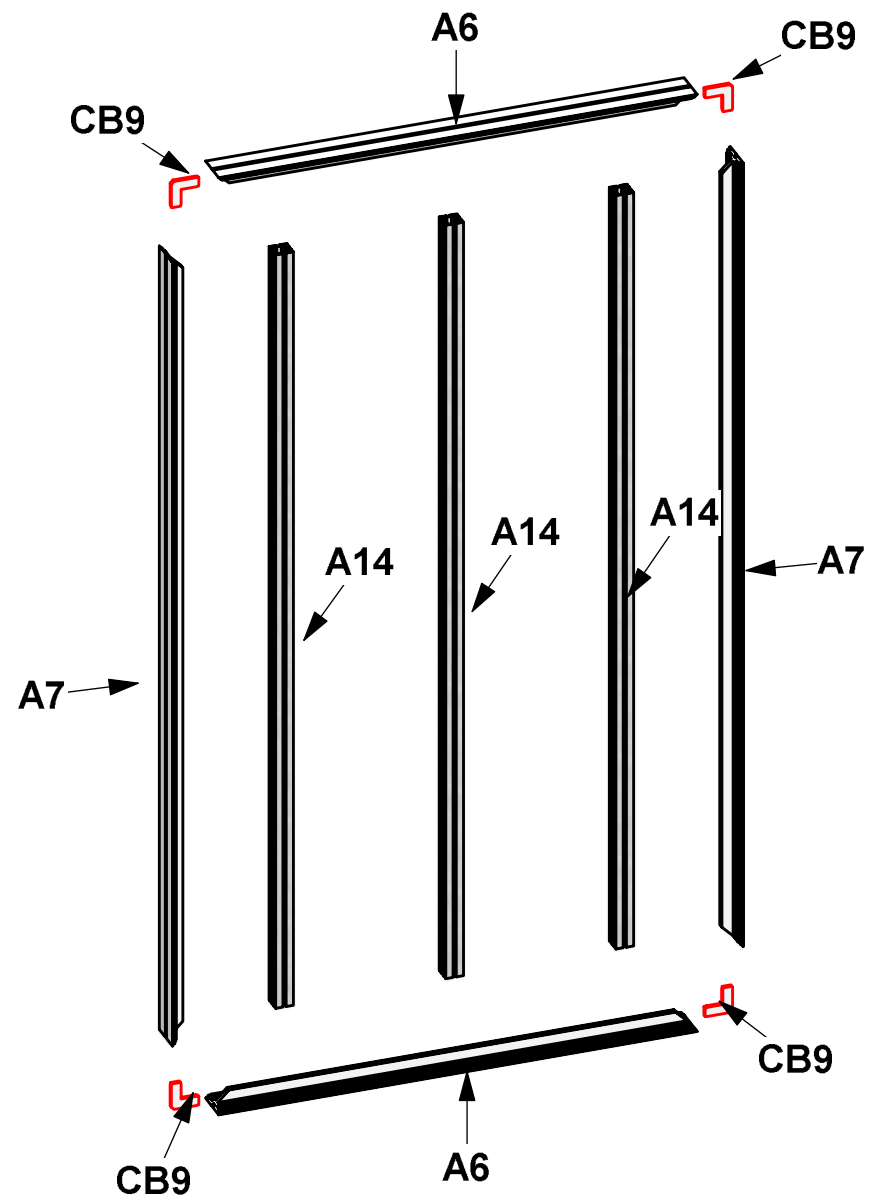

- 2400mm = (94 1/2")
  - 2100mm = (82 5/8")
  - 1800mm = (70 7/8")
  - 1500mm = (59")
  - 1200mm = (47 1/4")
  - 900mm = (35 1/2")
  - 600mm = (23 5/8")
  - 300mm = (11 7/8")
- ▼ Phone Line / Fax
  - ▼ Internet connection
  - ▼ Outlet
  - ▼ Main Drop (point of distrution)
- Wire running under carpet

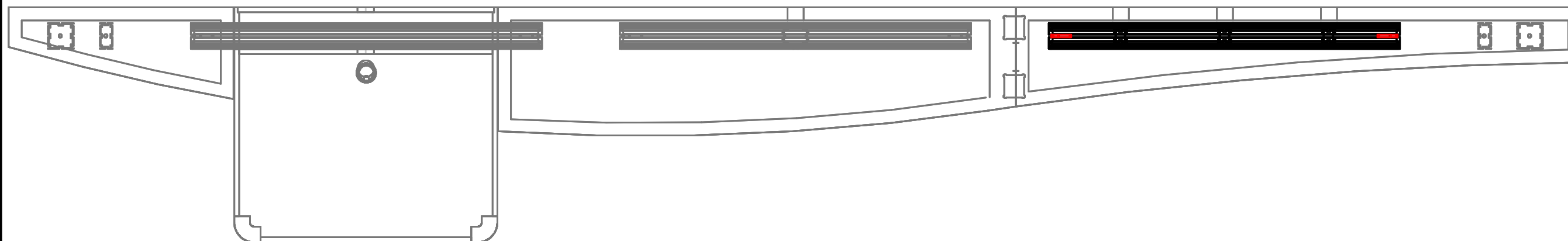
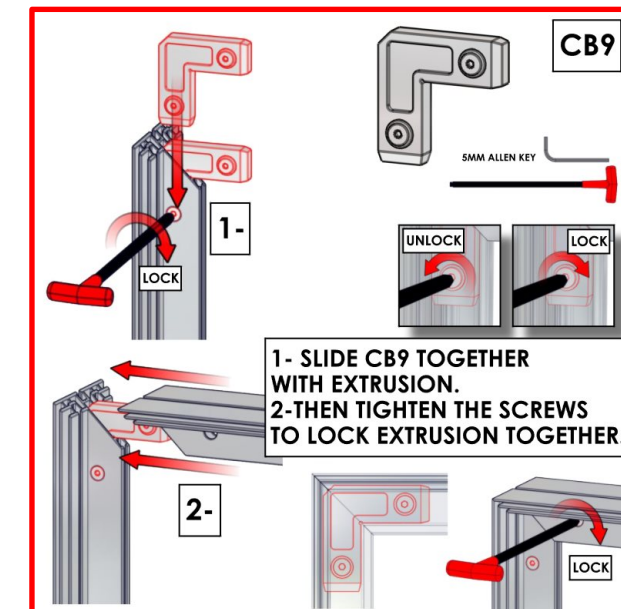
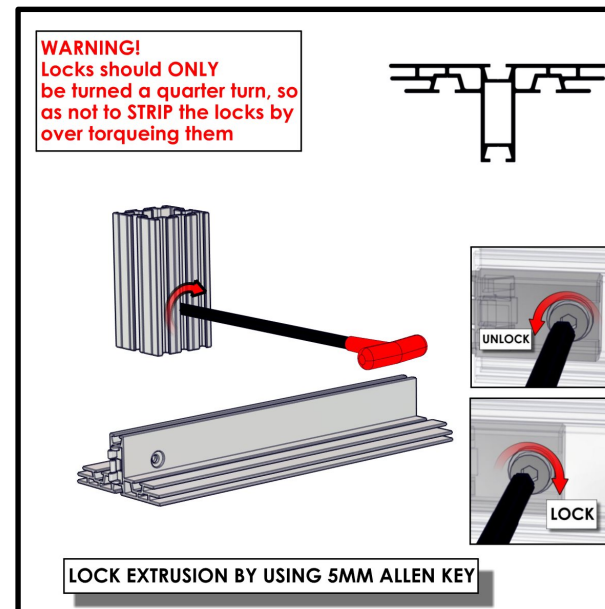
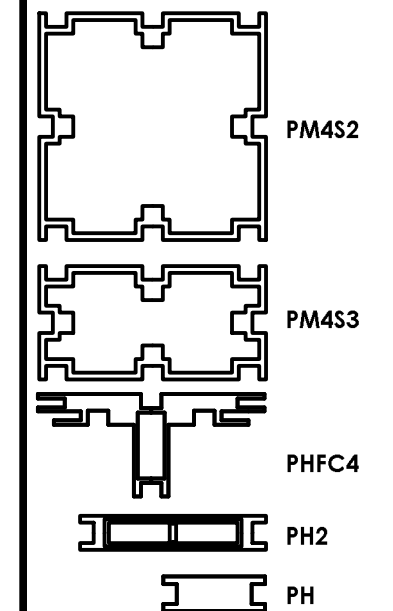

Code	#	Description
A8	8	300MM LENGTH OF PH EXTRUSION-WITH CAM LOCKS-WITH CAM LOCKS
A11	8	100MM LENGTH OF PH2 EXTRUSION-WITH CAM LOCKS BOTH ENDS

**WARNING!**  
Locks should ONLY be turned a quarter turn, so as not to STRIP the locks by over torquing them

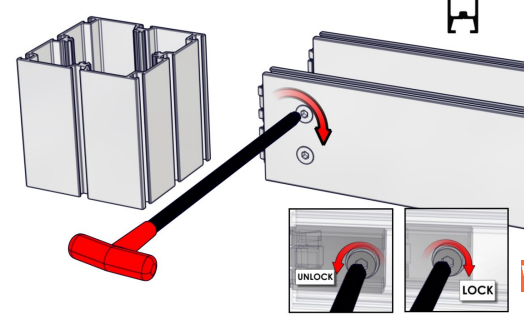

LOCK EXTRUSION BY USING 5MM ALLEN KEY

**WARNING!**  
Locks should ONLY be turned a half (or quarter) turn so as not to STRIP the locks by over torquing them

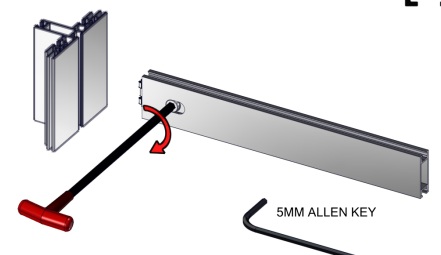

LOCK EXTRUSION BY USING 5MM ALLEN KEY

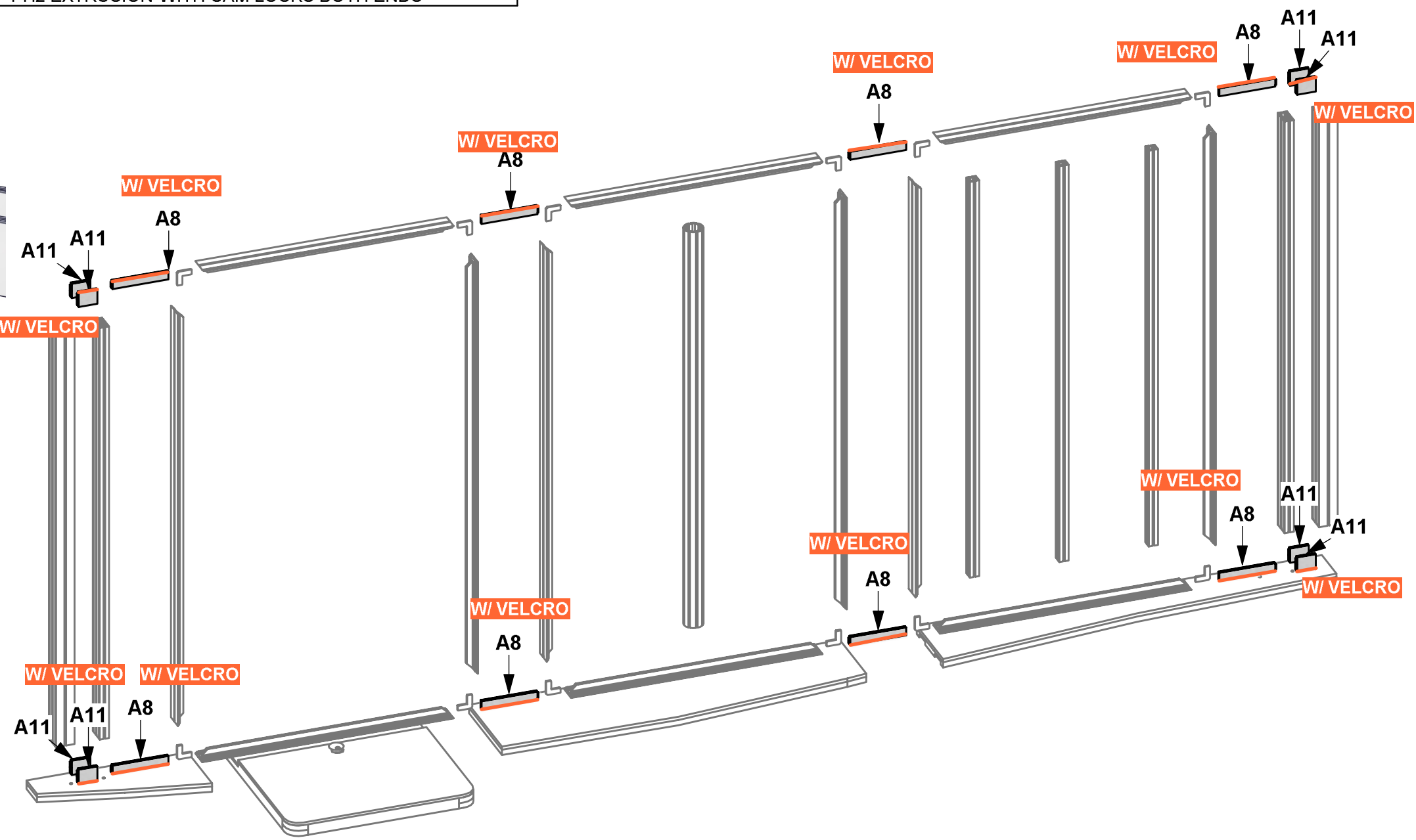

- 2400mm = (94 1/2")
  - 2100mm = (82 5/8")
  - 1800mm = (70 7/8")
  - 1500mm = (59")
  - 1200mm = (47 1/4")
  - 900mm = (35 1/2")
  - 600mm = (23 5/8")
  - 300mm = (11 7/8")
- Phone Line / Fax
  - Internet connection
  - Outlet
  - Main Drop (point of distrution)
  - Wire running under carpet

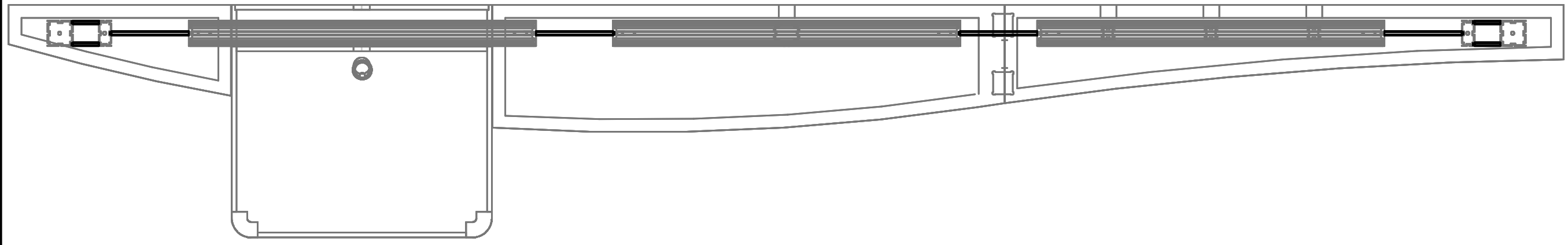
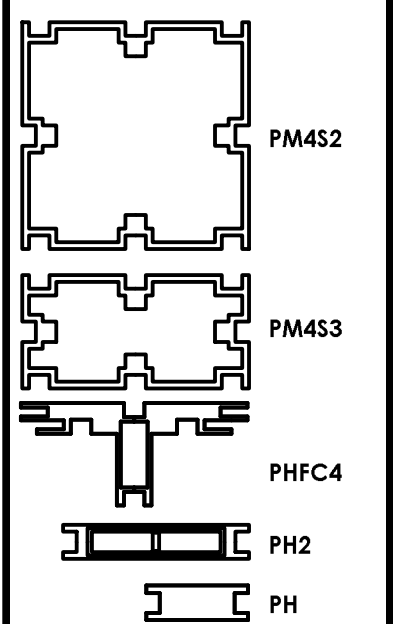

Code	#	Description
A11	8	100MM LENGTH OF PH2 EXTRUSION-WITH CAM LOCKS BOTH ENDS
A13	4	PM2S2-1200 EXTRUSION
CUS-SW-FOO	1	SMART WALL FOOT , CUT DOWN TO 300MM, WITH LN100 & M5 THUMBSCREWS
CUS-SW-FOO	3	**METAL SHOP**SMART WALL FOOT , CUT DOWN TO 300MM, WITH LN100 & M5 THUMBSCREWS **SEE DETAIL**

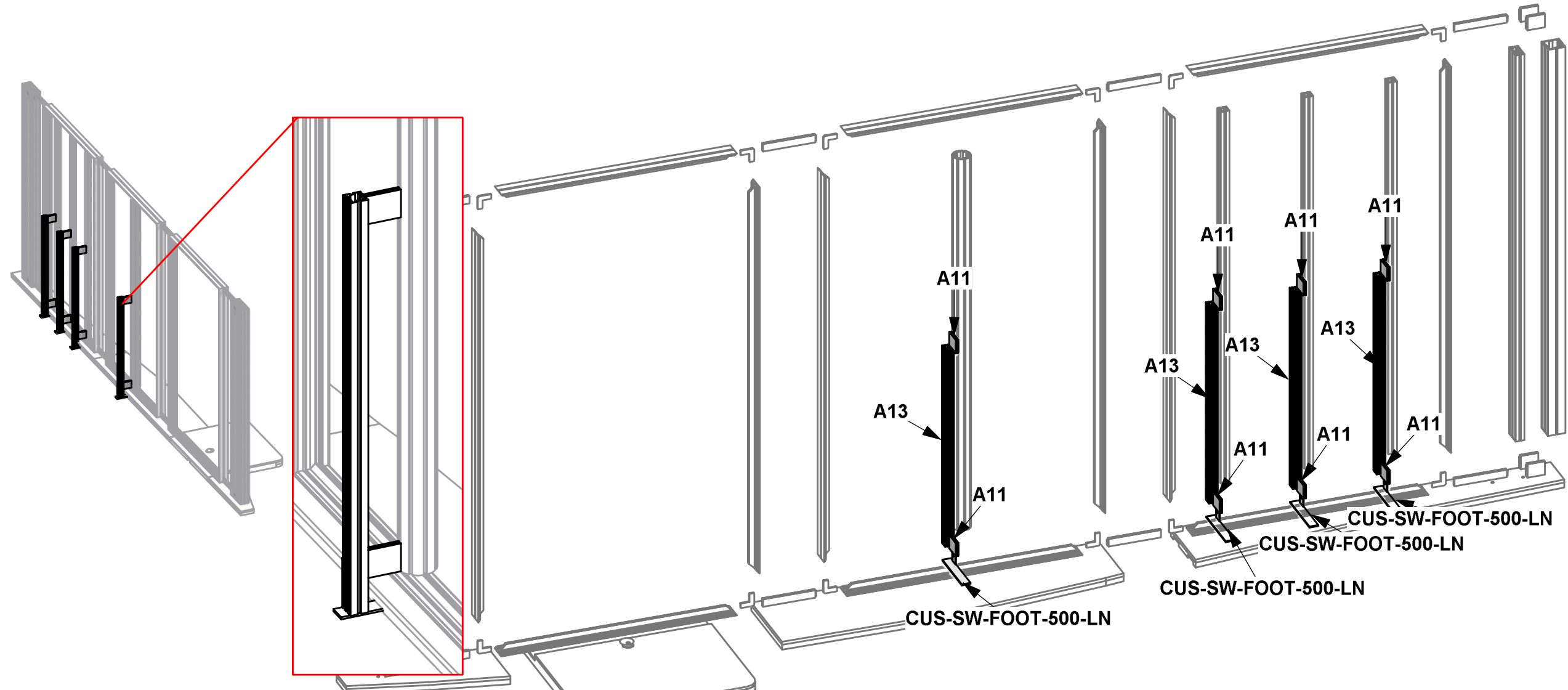

- 2400mm = (94 1/2") Phone Line / Fax
  - 2100mm = (82 5/8") Internet connection
  - 1800mm = (70 7/8") Outlet
  - 1500mm = (59")
  - 1200mm = (47 1/4")
  - 900mm = (35 1/2")
  - 600mm = (23 5/8") Main Drop (point of distrution)
  - 300mm = (11 7/8")
- Wire running under carpet

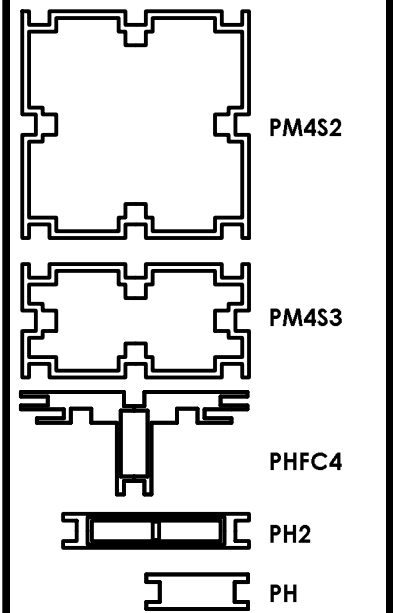

**WARNING!**  
Locks should ONLY be turned a quarter turn, so as not to STRIP the locks by over torqueing them

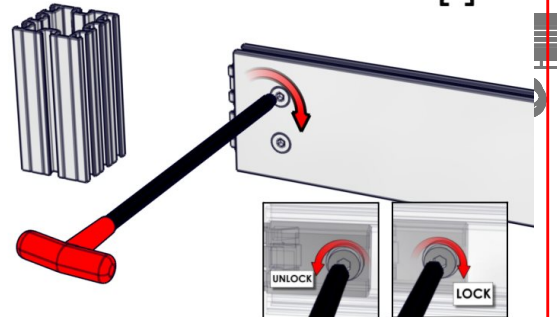

LOCK EXTRUSION BY USING 5MM ALLEN KEY

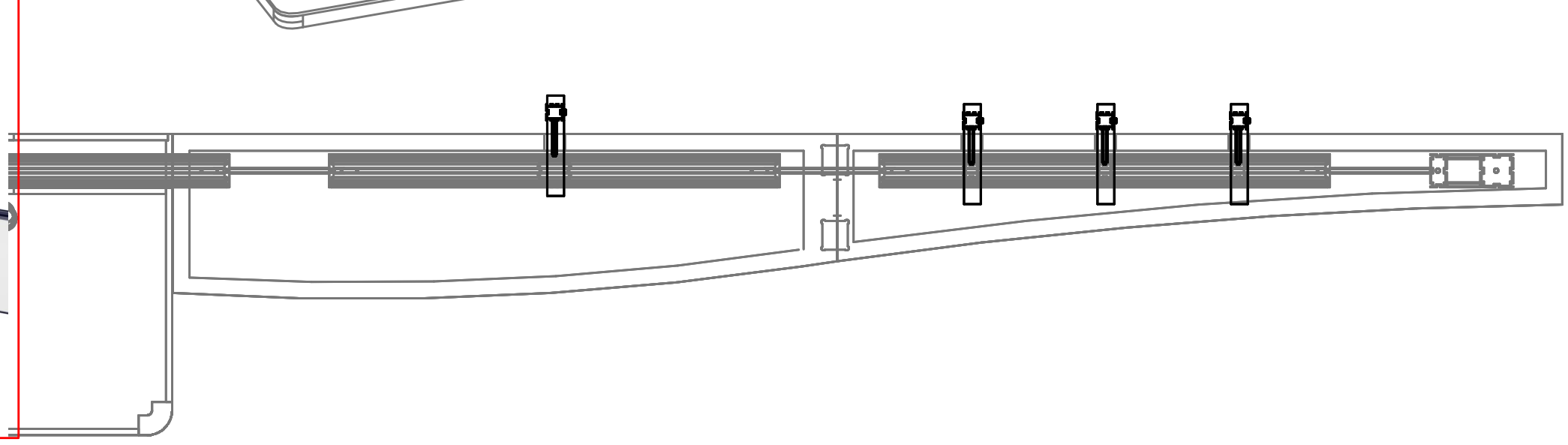

Code	#	Description
WME-2259	8	2259MM WME EXTRUSION

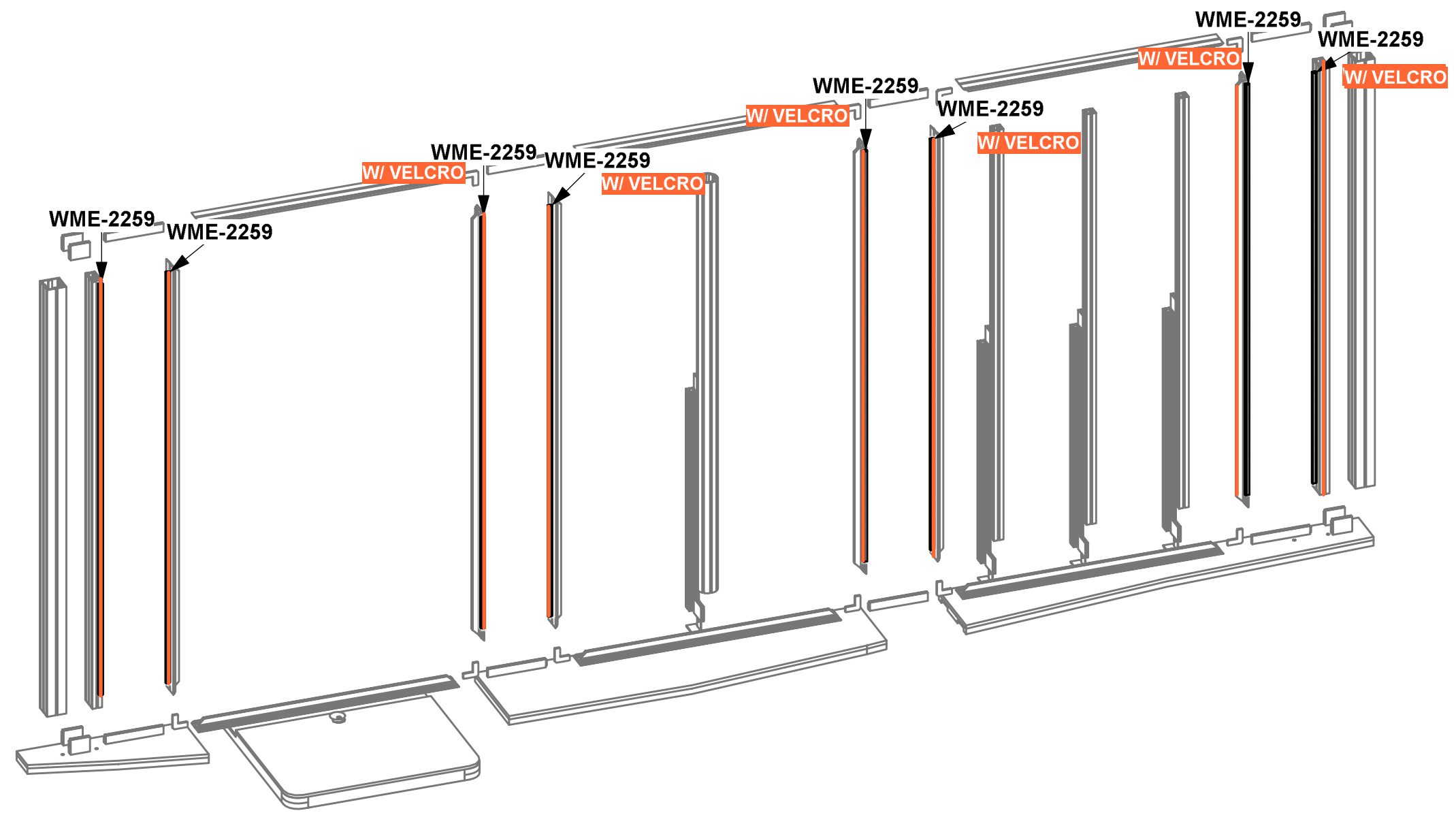

- 2400mm = (94 1/2")
  - 2100mm = (82 5/8")
  - 1800mm = (70 7/8")
  - 1500mm = (59")
  - 1200mm = (47 1/4")
  - 900mm = (35 1/2")
  - 600mm = (23 5/8")
  - 300mm = (11 7/8")
- ▼ Phone Line / Fax
  - ▼ Internet connection
  - ▼ Outlet
  - ▼ Main Drop (point of distrution)
  - Wire running under carpet

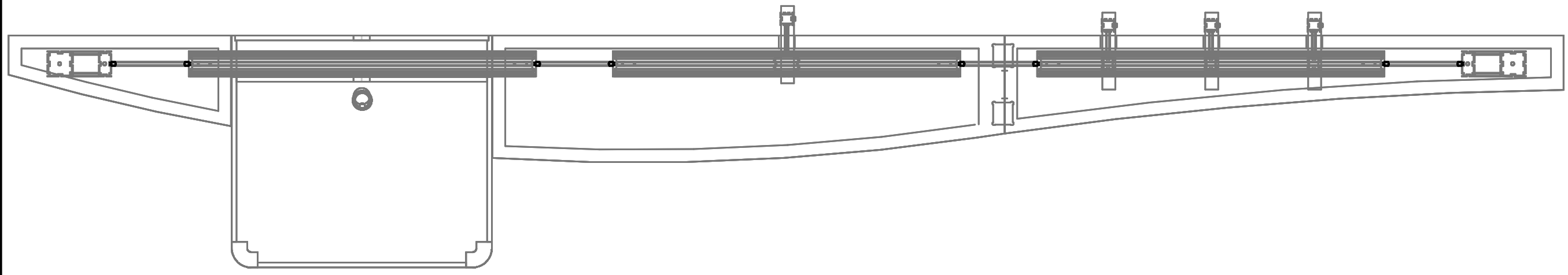
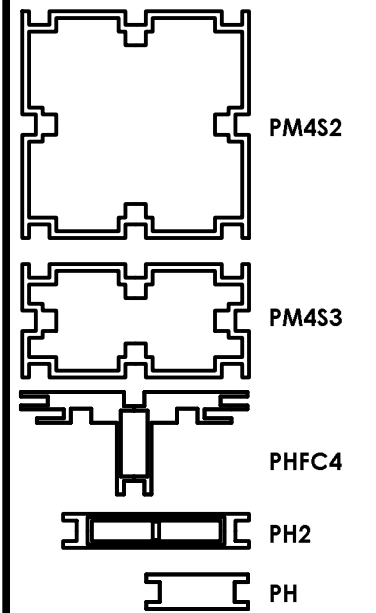

Code	#	Description
MM-M-T	1	MEDIUM SIZE LCD MONITOR MOUNT, 32"-55" SIZE, 80 LB. MAX.
GRAPHIC (C1)	1	53.03 w X 92.36 h FABRIC WITH FCE-2
GRAPHIC (C2)	1	53.03 w X 92.36 hh FABRIC WITH FCE-2
GRAPHIC (C3)	1	53.03 w X 92.36 h FABRIC WITH FCE-2

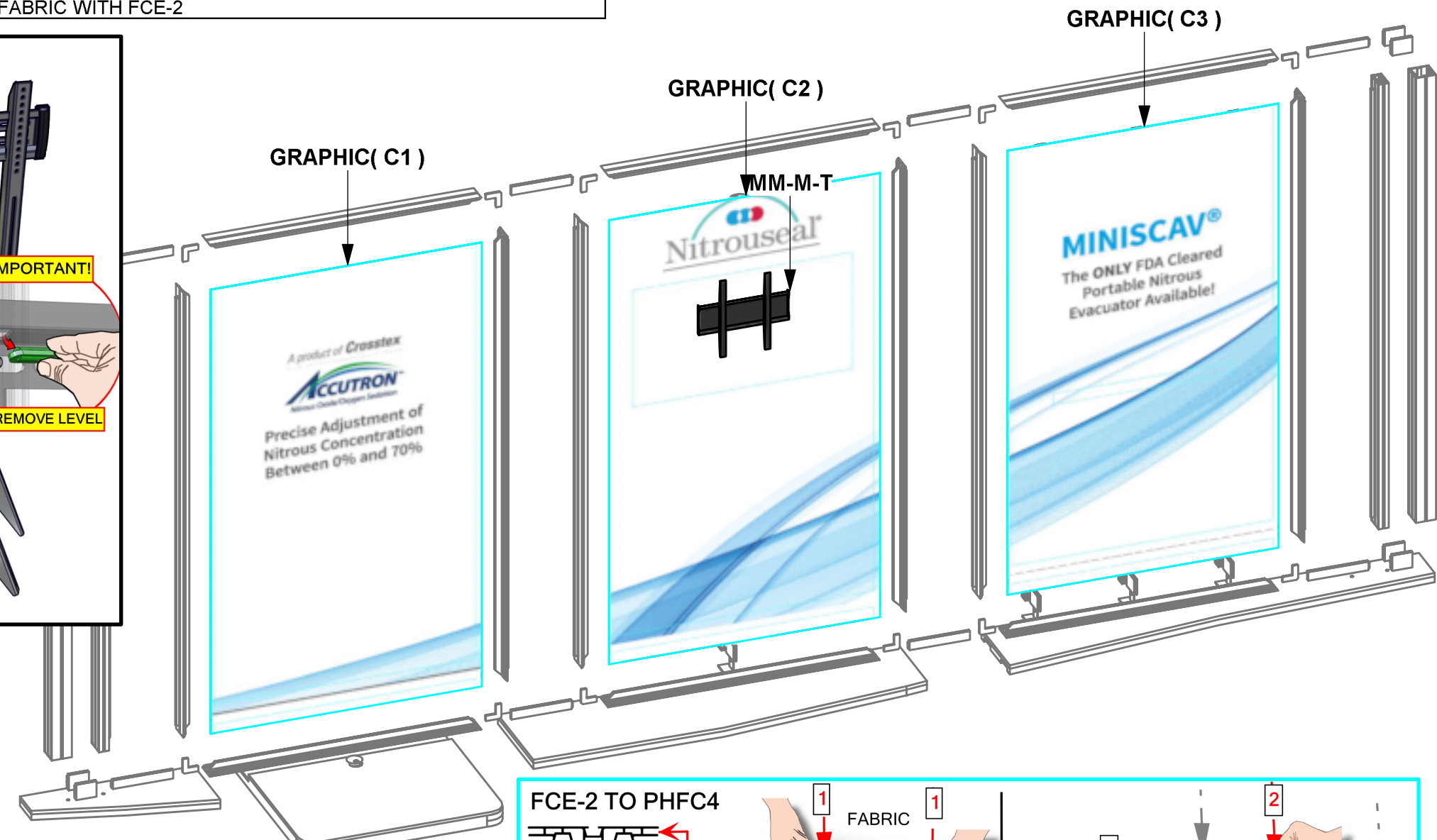
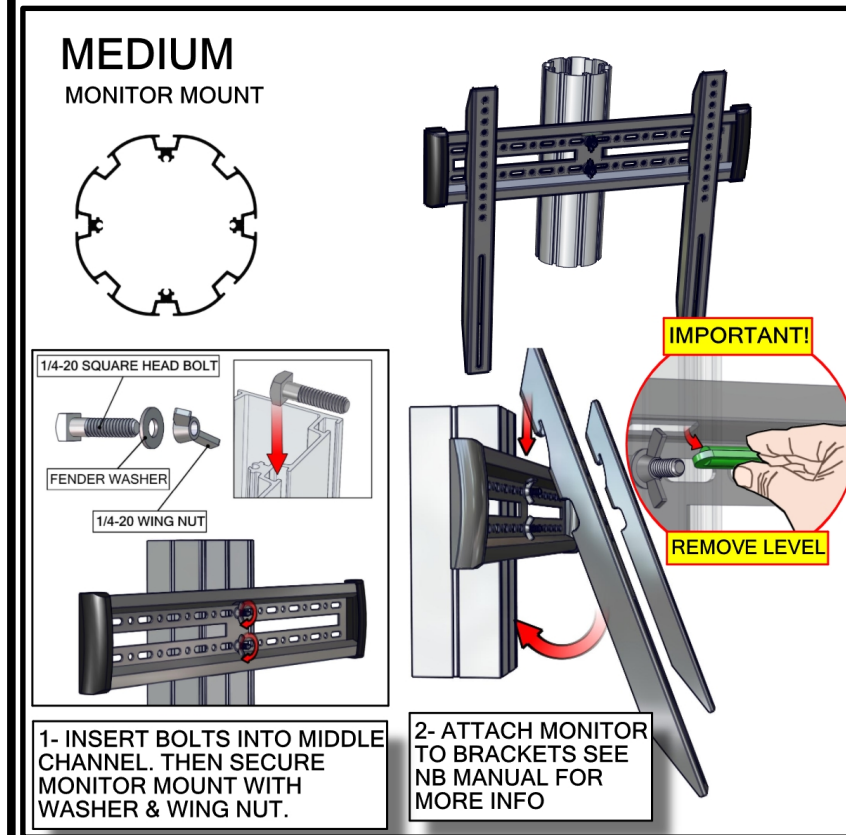

- 2400mm = (94 1/2")
  - 2100mm = (82 5/8")
  - 1800mm = (70 7/8")
  - 1500mm = (59")
  - 1200mm = (47 1/4")
  - 900mm = (35 1/2")
  - 600mm = (23 5/8")
  - 300mm = (11 7/8")
- Phone Line / Fax
  - Internet connection
  - Outlet
  - Main Drop (point of distrution)
- Wire running under carpet

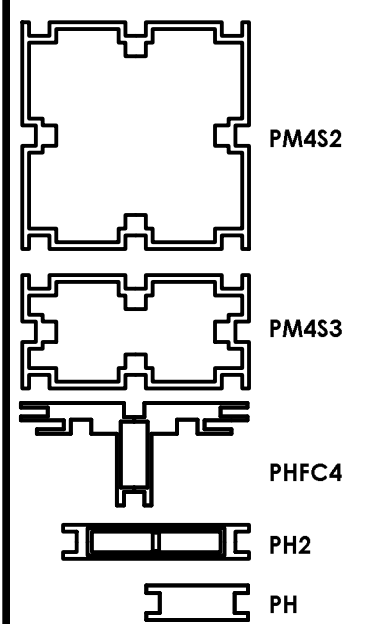

#### FCE-2 TO PHFC4

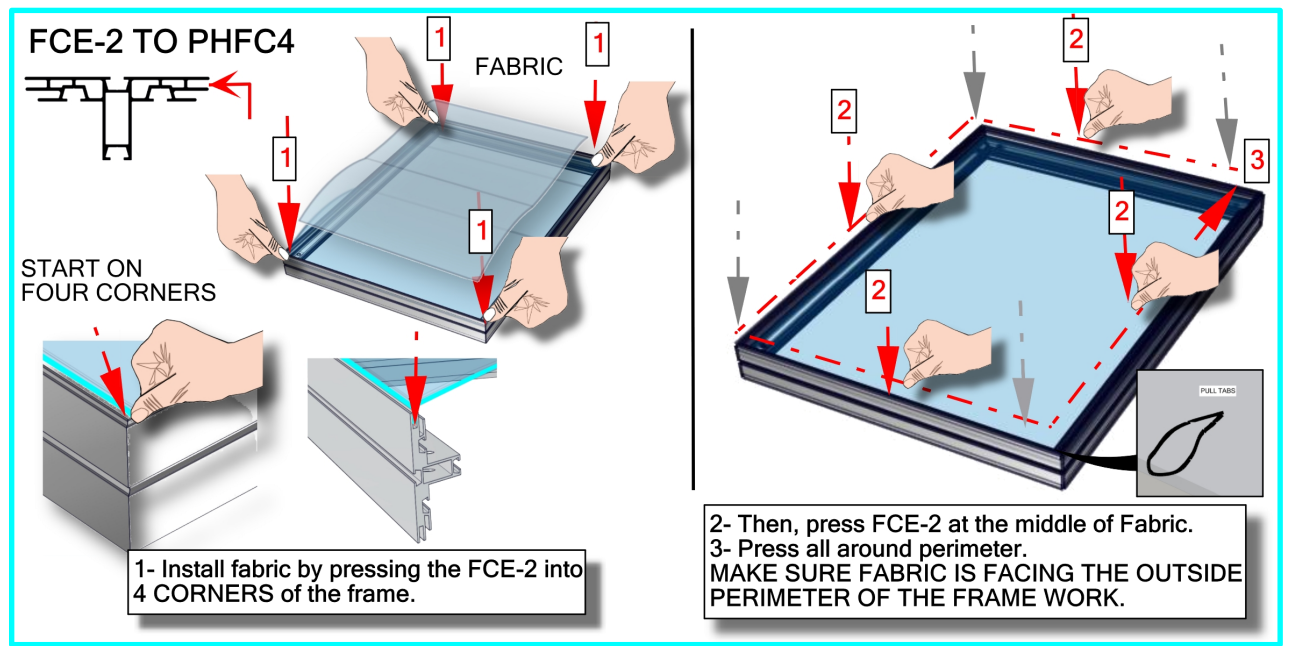
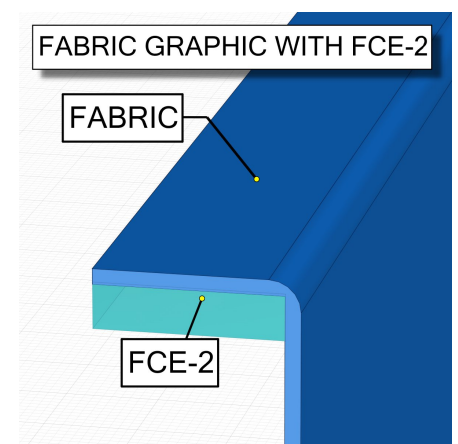
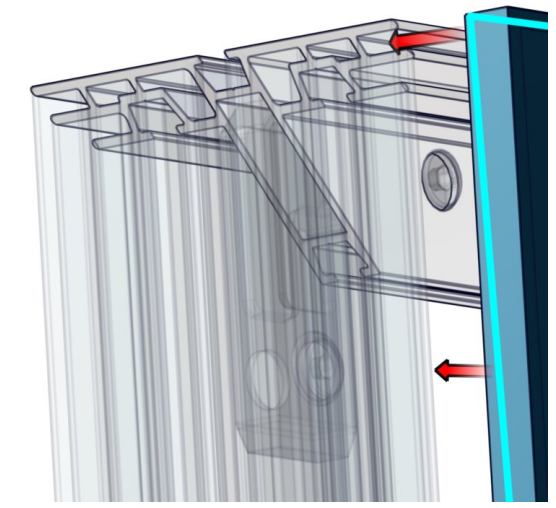

Code	#	Description
GRAPHIC( A1 )	1	9.84 w X 92.48 h PVC WITH VELCRO
GRAPHIC( B1 )	1	11.81 w X 92.48 h PVC WITH VELCRO
GRAPHIC( B2 )	1	11.81 w X 92.48 h PVC WITH VELCRO
GRAPHIC( B3 )	1	11.81 w X 92.48 h h PVC WITH VELCRO
GRAPHIC( B4 )	1	11.81 w X 92.48 h PVC WITH VELCRO
GRAPHIC( D1 )	1	5.91 w X 92.48 h PVC WITH VELCRO

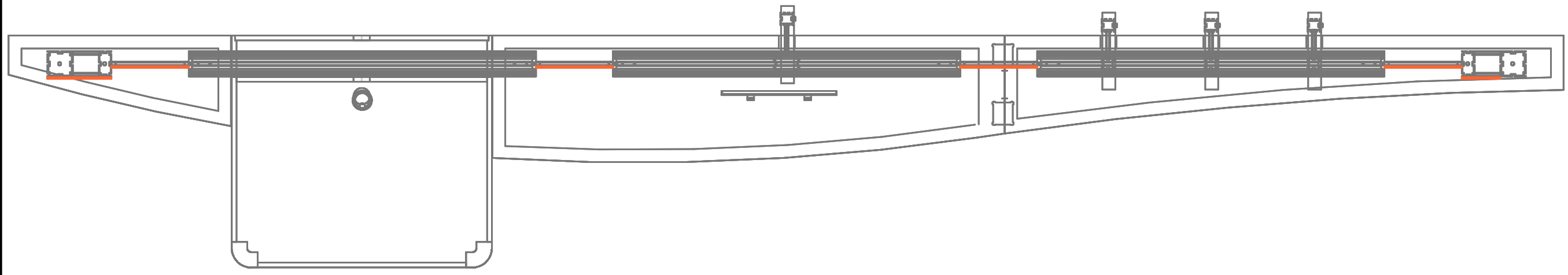
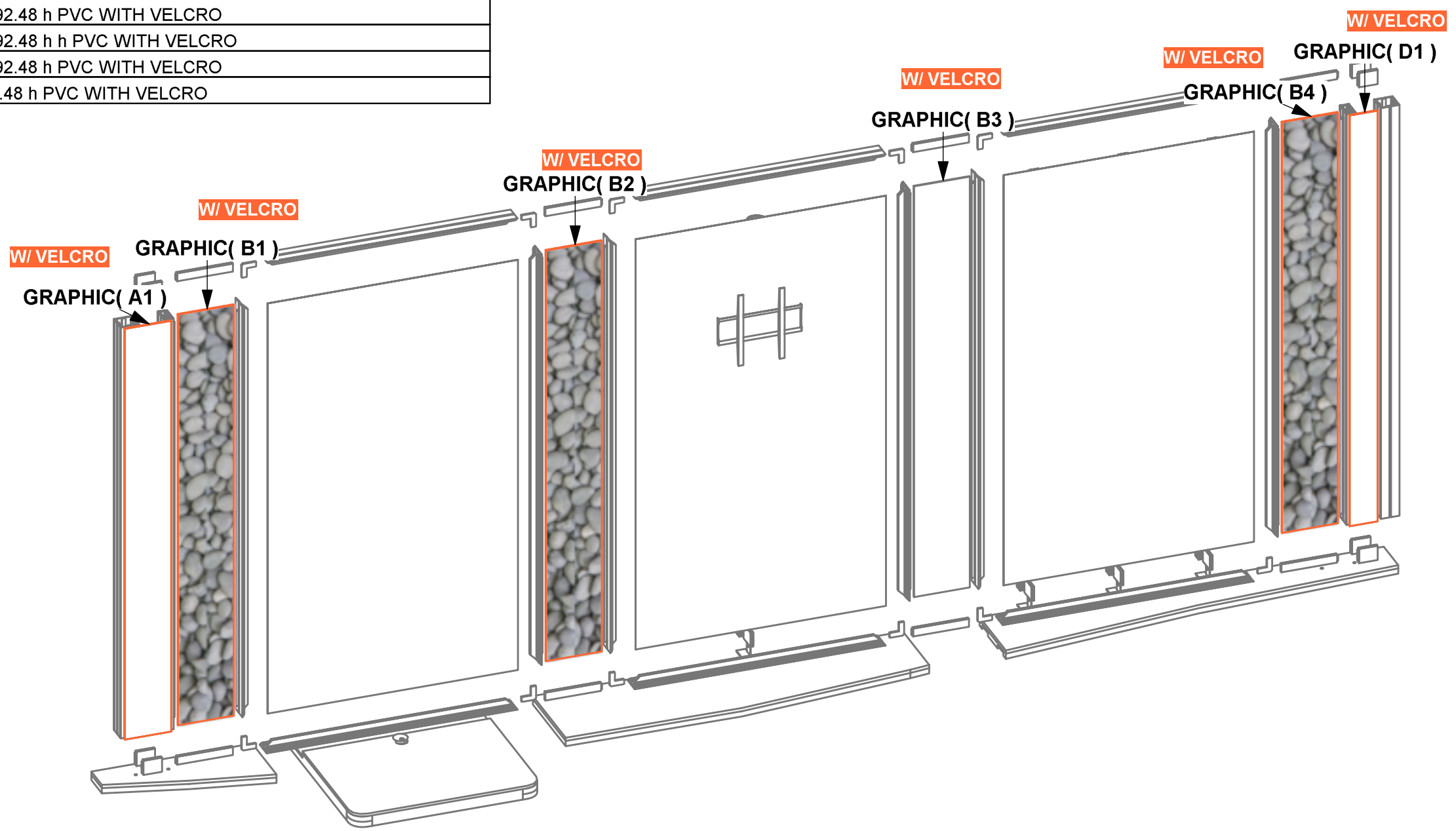

- 2400mm = (94 1/2")
  - 2100mm = (82 5/8")
  - 1800mm = (70 7/8")
  - 1500mm = (59")
  - 1200mm = (47 1/4")
  - 900mm = (35 1/2")
  - 600mm = (23 5/8")
  - 300mm = (11 7/8")
- ▼ Phone Line / Fax
  - ▼ Internet connection
  - ▼ Outlet
  - ▼ Main Drop (point of distrution)
  - Wire running under carpet

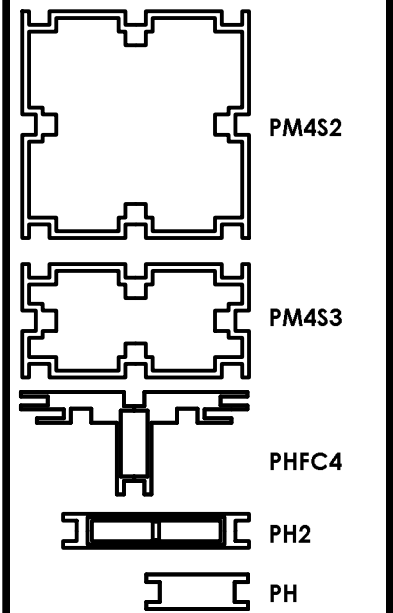

Code	#	Description
SO-1 1/4 D CA	3	1 1/4" D X 1/2" L X 5/16" STANDOFF CAP
CUS-WOOD-IT	1	**CNC**50" W X 4.5" D X 5'H Planter Box**WILSONART DESIGNER WHITE**
C1	1	**CNC** 36" X 12" 2.5" Thick Laminate wood shelf **WILSONART DESIGNER WHITE**

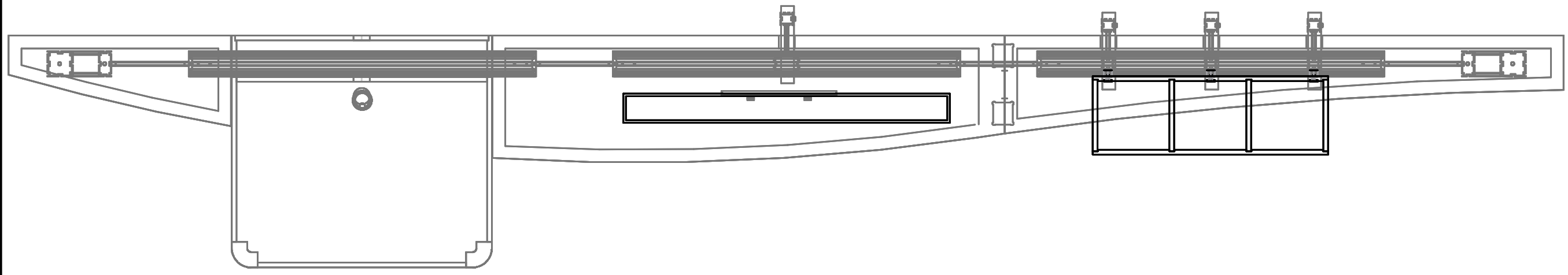
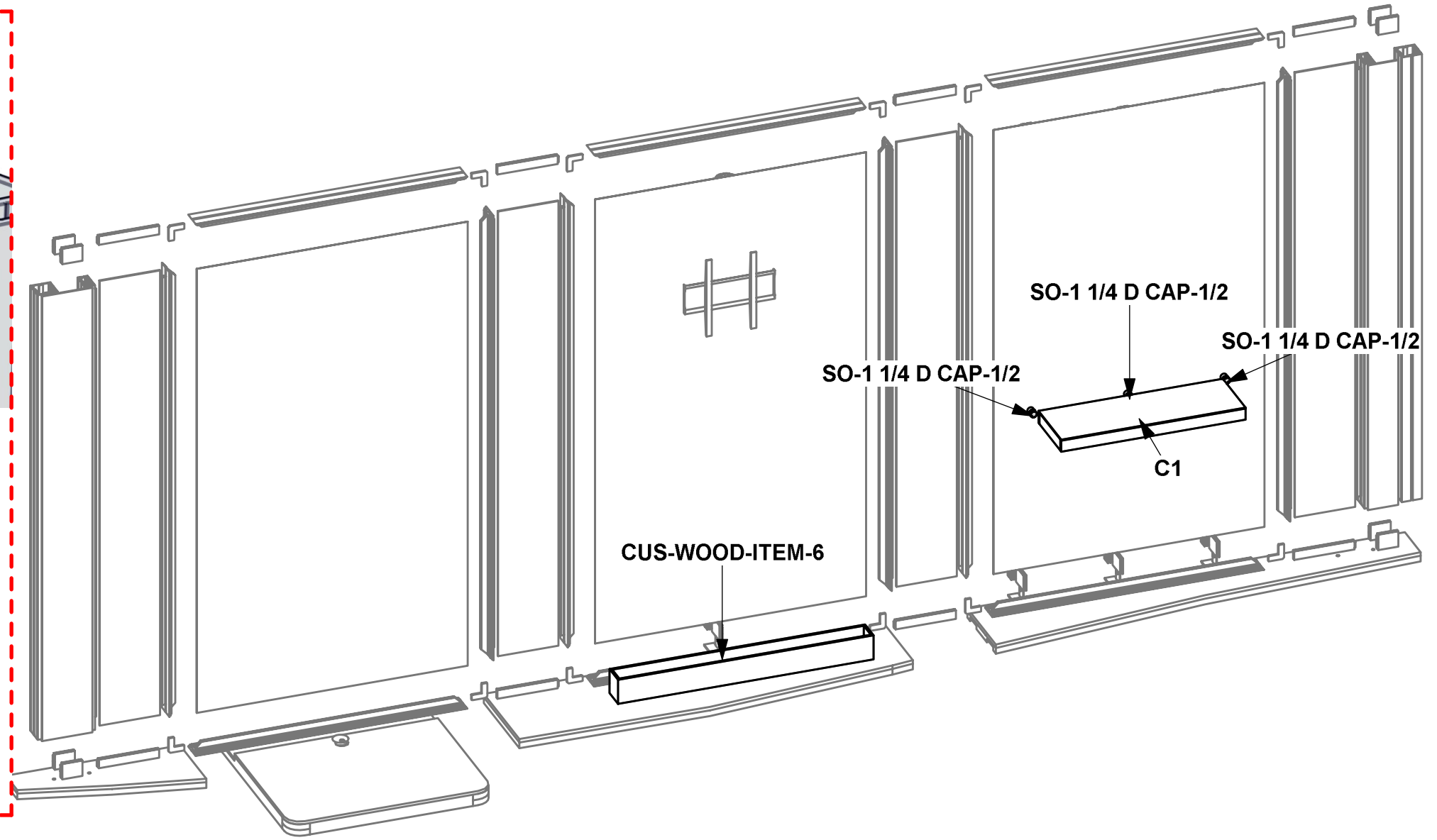
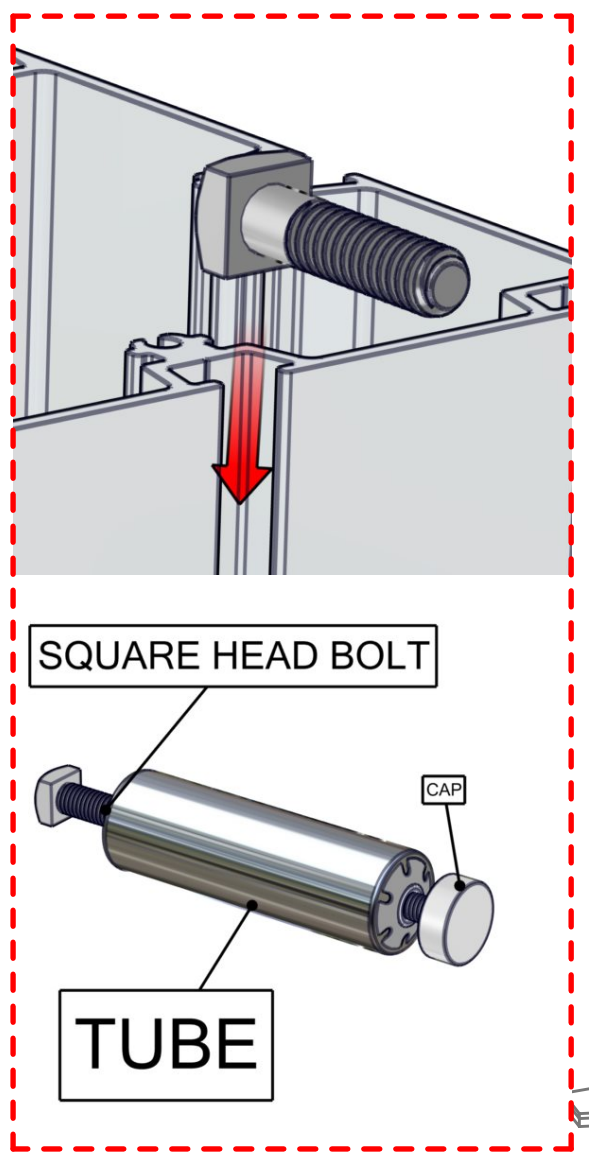

- 2400mm = (94 1/2")
  - 2100mm = (82 5/8")
  - 1800mm = (70 7/8")
  - 1500mm = (59")
  - 1200mm = (47 1/4")
  - 900mm = (35 1/2")
  - 600mm = (23 5/8")
  - 300mm = (11 7/8")
- ▼ Phone Line / Fax
  - ⚡ Internet connection
  - ⚡ Outlet
  - ⚡ Main Drop (point of distrution)
- Wire running under carpet

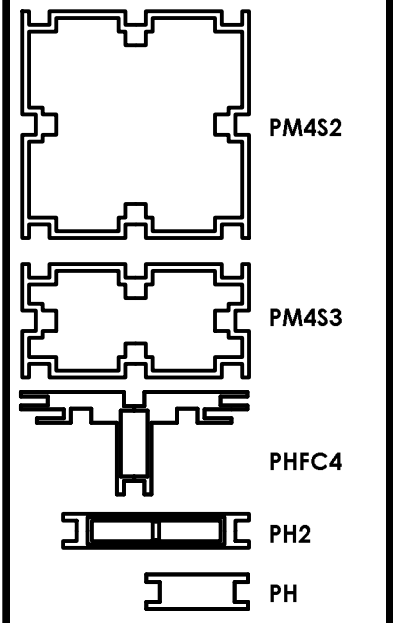



Code	#	Description
A1	1	2400MM PM4S2-2400 EXTRUSION-WITH STOP AT 315MM-WITH STOP AT 315MM
A2	3	PM4S2-1200 EXTRUSION-WITH CAM LOCKS-WITH CAM LOCKS

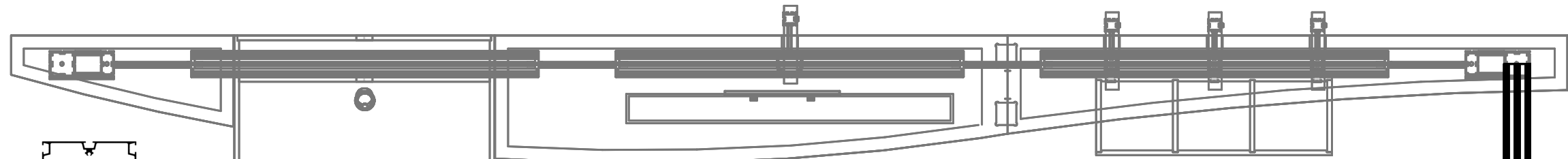

**WARNING!**  
Locks should ONLY be turned a quarter turn, so as not to STRIP the locks by over torquing them

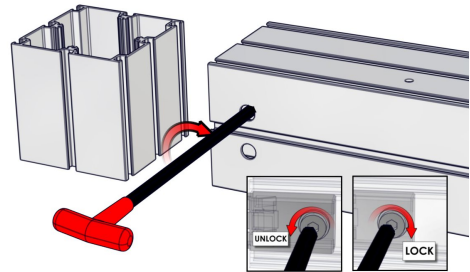
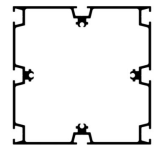

LOCK EXTRUSION BY USING 5MM ALLEN KEY

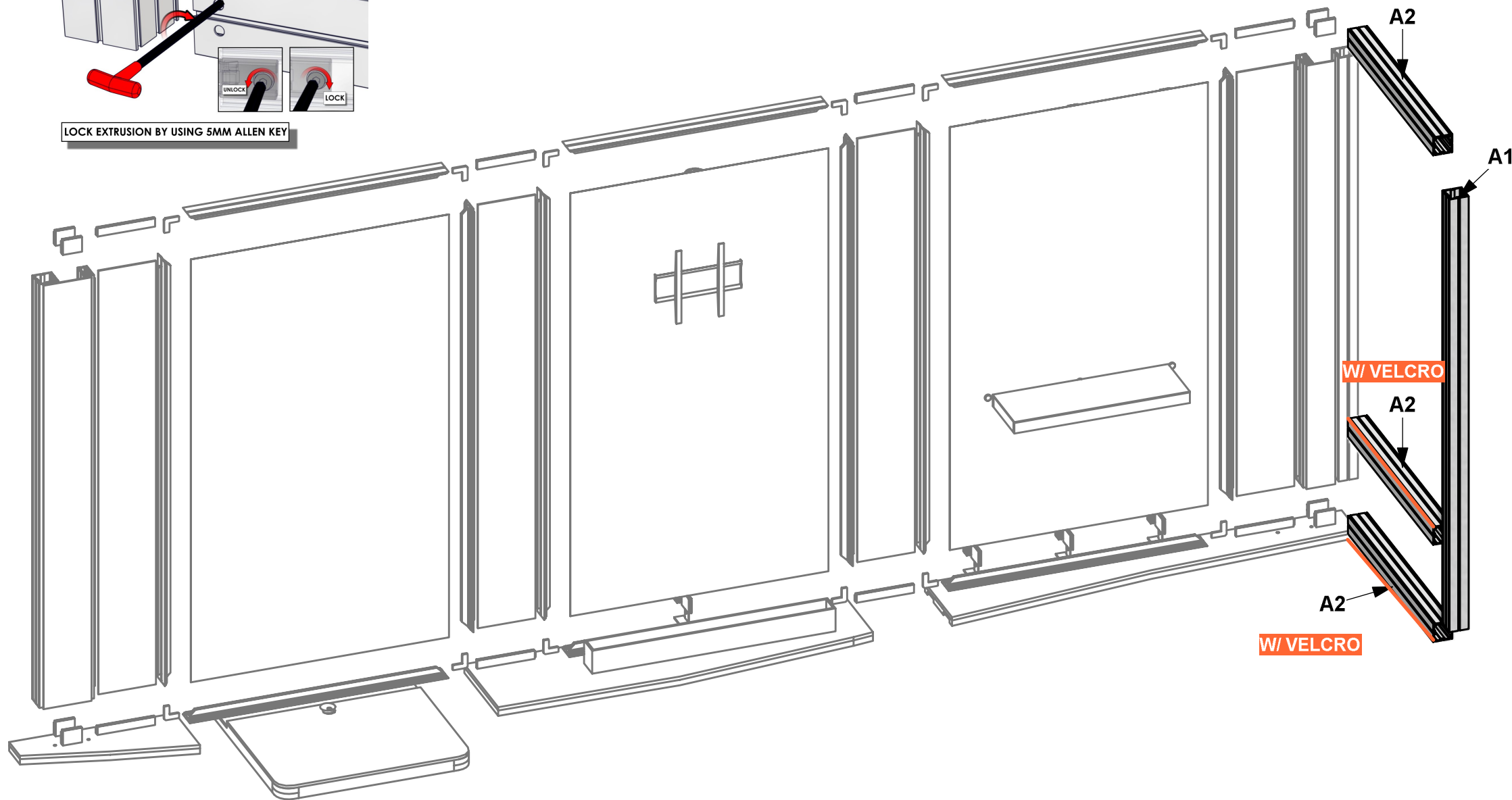

- 2400mm = (94 1/2")
  - 2100mm = (82 5/8")
  - 1800mm = (70 7/8")
  - 1500mm = (59")
  - 1200mm = (47 1/4")
  - 900mm = (35 1/2")
  - 600mm = (23 5/8")
  - 300mm = (11 7/8")
- ▼ Phone Line / Fax
  - ▼ Internet connection
  - ▼ Outlet
  - ▼ Main Drop (point of distrution)
- Wire running under carpet

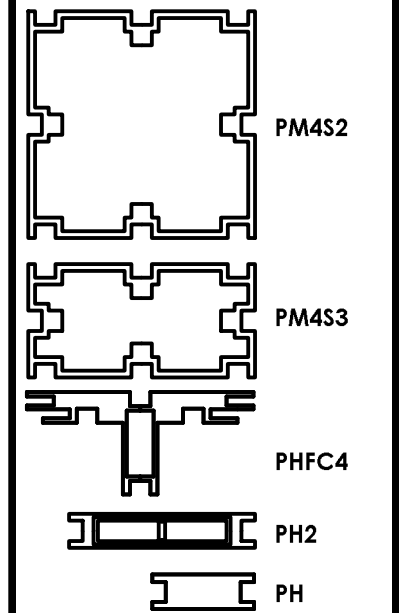

Code	#	Description
A3	7	1160MM X 200MM X 6MM SINTRA (WHITE)
CKAPS	28	CABLE KIT, 7MM PANEL SUPPORT

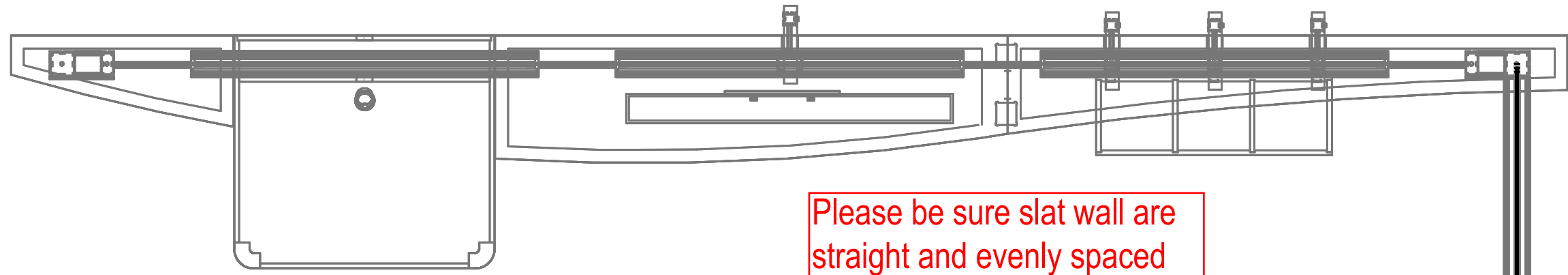

Please be sure slat wall are straight and evenly spaced

**CKAP**

1

2

Screw the CKAP, clockwise, into the channel until it is tight. Loosen the head screw and make sure the slit in the head is running the correct direction, then tighten back into place. Loosen the hex bolt screw and insert the SINTRA and tighten into place.

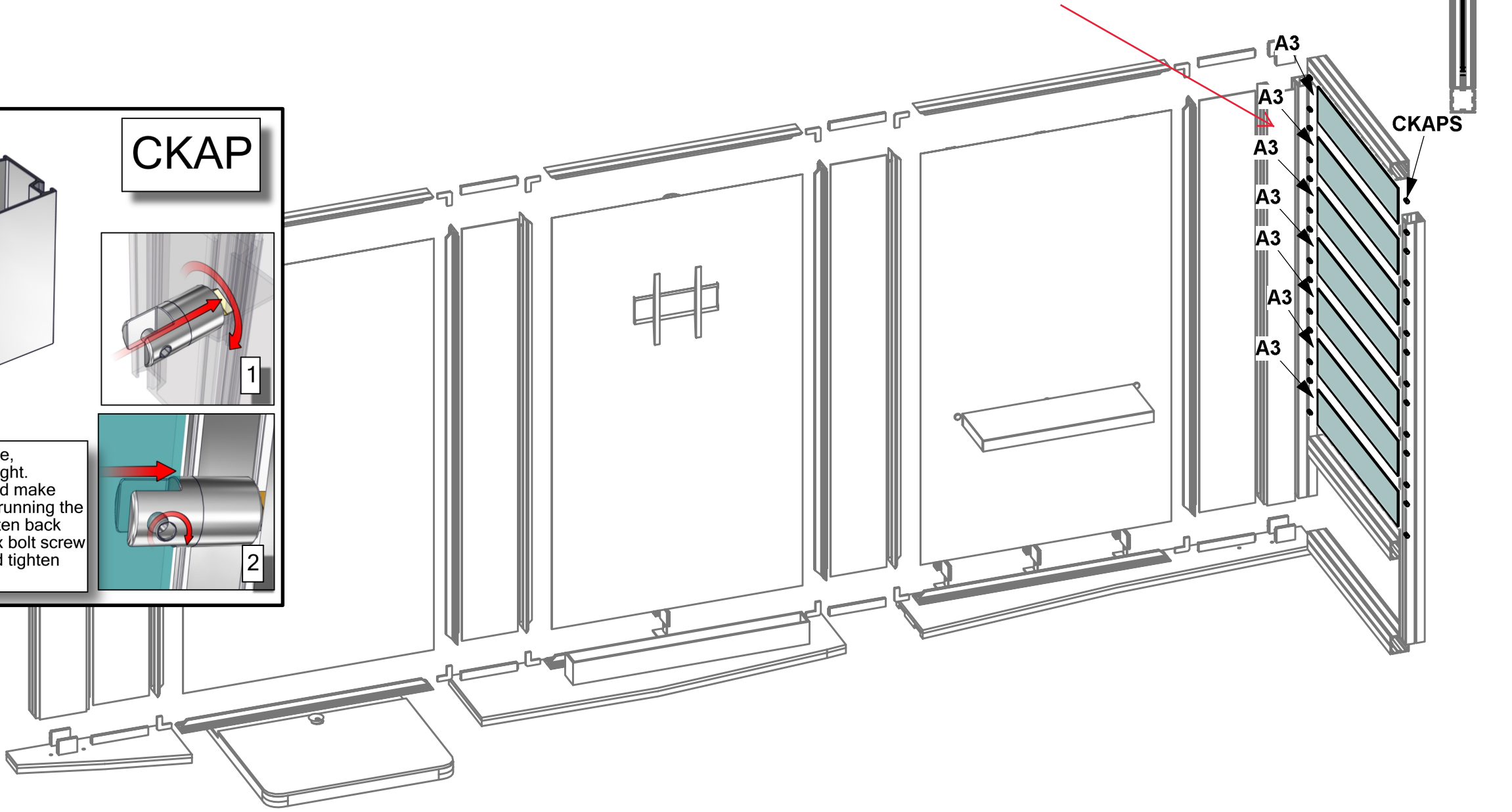

- 2400mm = (94 1/2") Phone Line / Fax
  - 2100mm = (82 5/8") Internet connection
  - 1800mm = (70 7/8") Outlet
  - 1500mm = (59") Main Drop (point of distrution)
  - 1200mm = (47 1/4")
  - 900mm = (35 1/2")
  - 600mm = (23 5/8")
  - 300mm = (11 7/8")
- Wire running under carpet

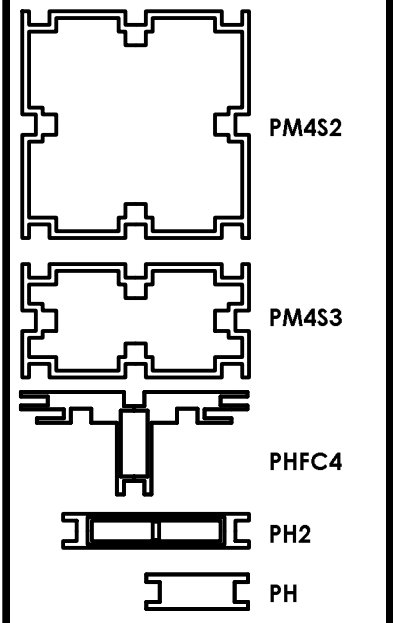

Code	#	Description
PM4S2-MCAP	2	PLASTIC END CAP FOR THE PM4S2 EXTRUSION
A4	2	600MM PM4S2-600 EXTRUSION
A5	4	610MM CUT DOWN FROM 900MM LENGTH OF PM4S2 EXTRUSION-WITH CAM LOCKS-WITH CAM LC

- 2400mm = (94 1/2")
  - 2100mm = (82 5/8")
  - 1800mm = (70 7/8")
  - 1500mm = (59")
  - 1200mm = (47 1/4")
  - 900mm = (35 1/2")
  - 600mm = (23 5/8")
  - 300mm = (11 7/8")
- ▼ Phone Line / Fax
  - ⚡ Internet connection
  - ⚡ Outlet
  - ⚡ Main Drop (point of distrution)
- Wire running under carpet

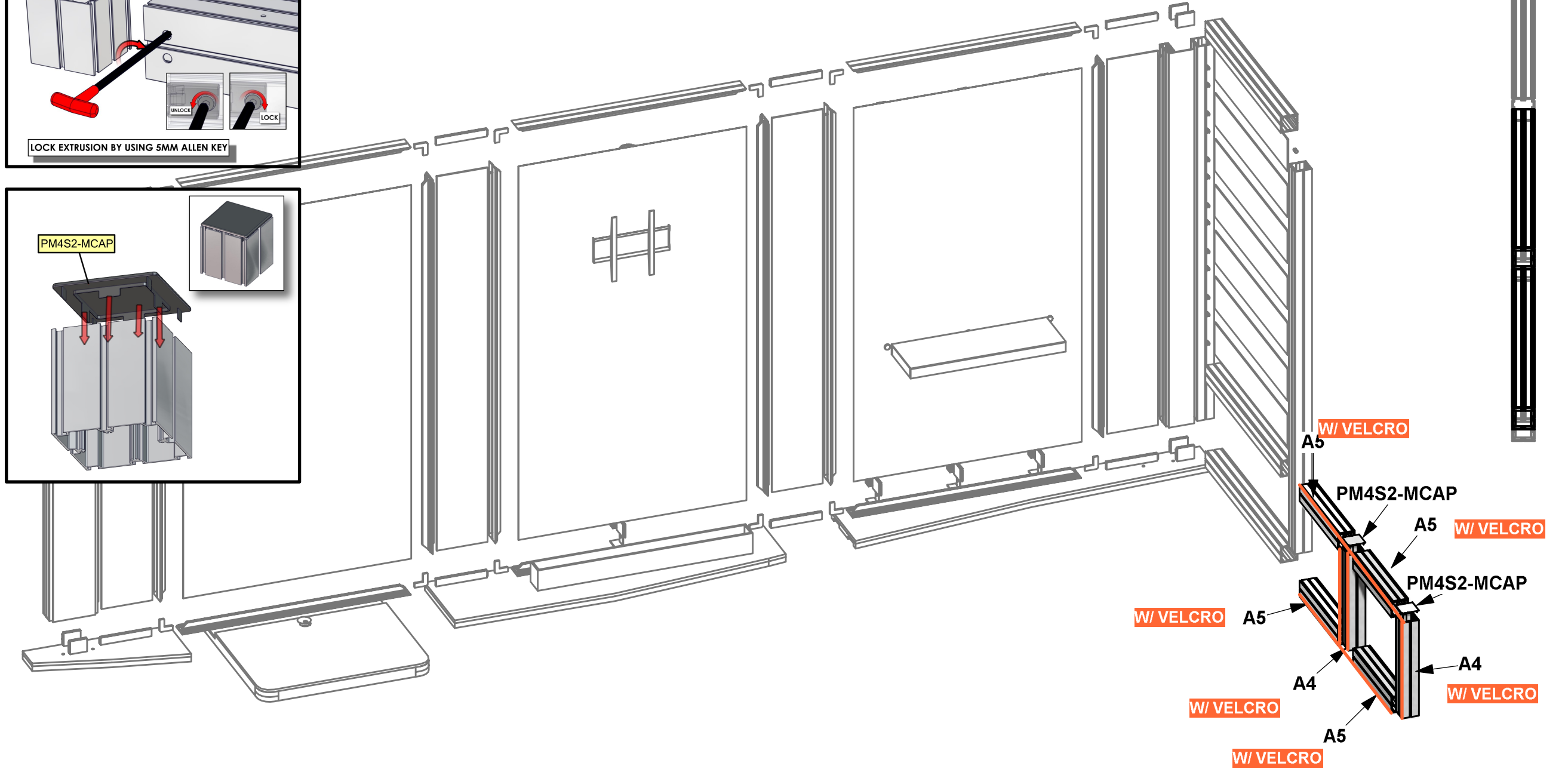
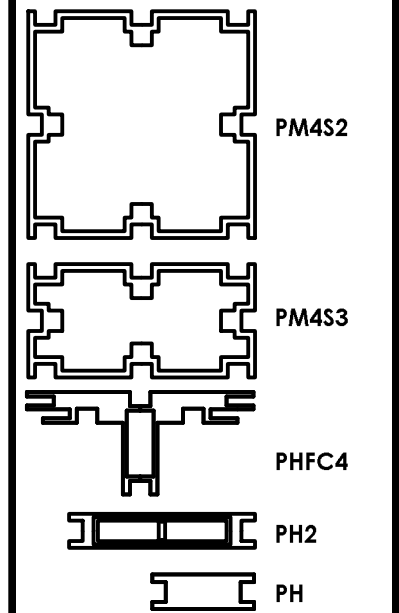
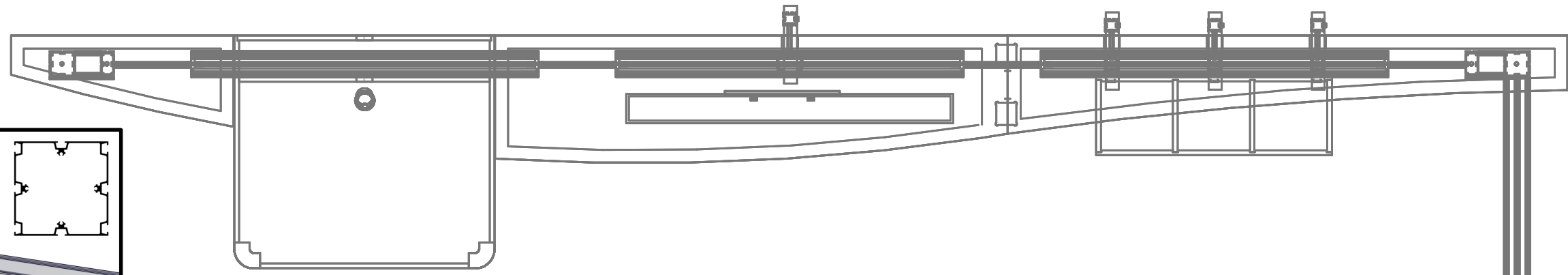
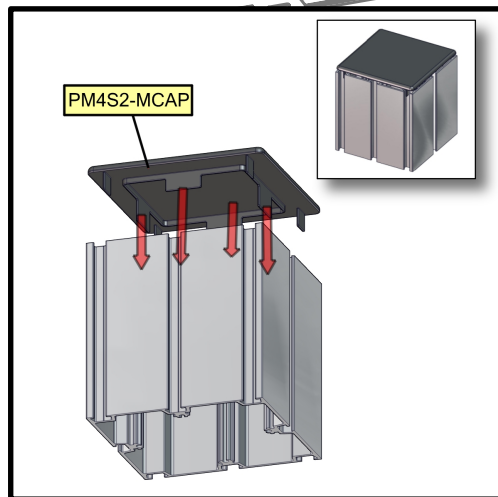
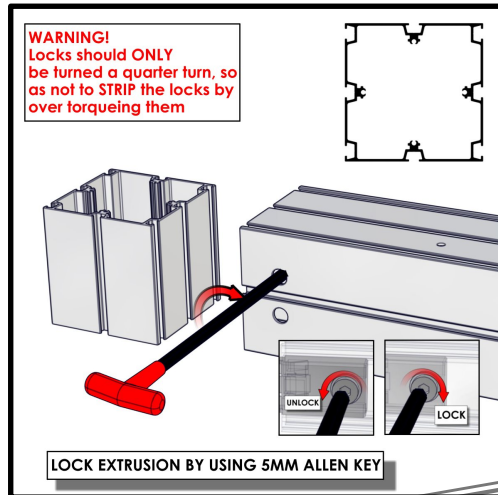

Code	#	Description
A17	1	1192MM X 549MM X 6MM SINTRA
A16	1	1520MM X 600MM X 6MM SINTRA

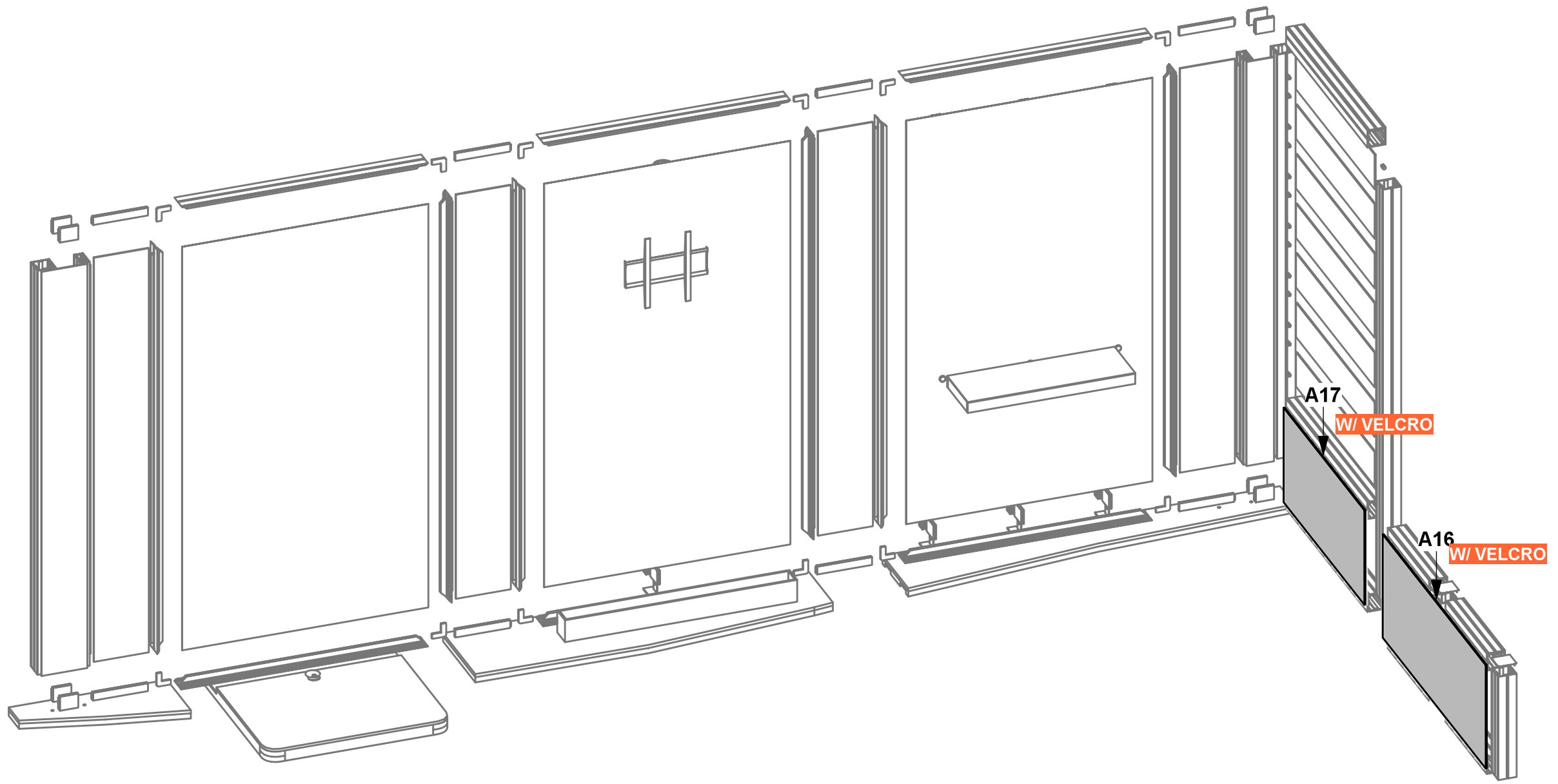
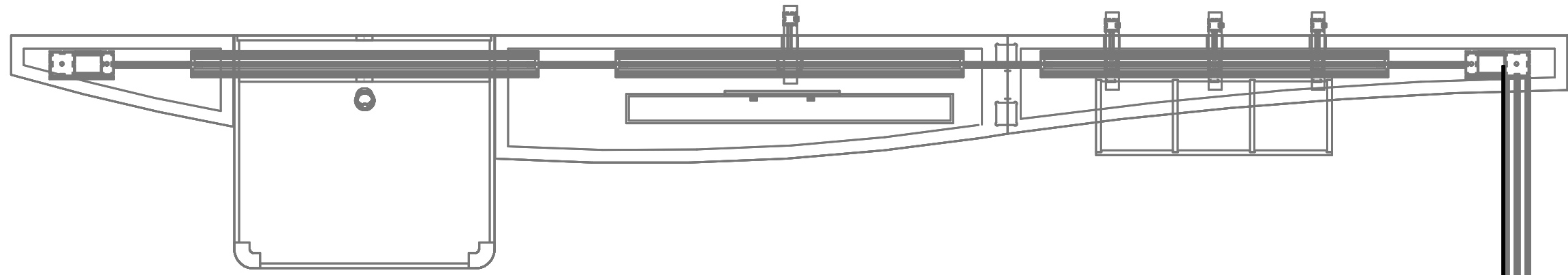

- 2400mm = (94 1/2")
  - 2100mm = (82 5/8")
  - 1800mm = (70 7/8")
  - 1500mm = (59")
  - 1200mm = (47 1/4")
  - 900mm = (35 1/2")
  - 600mm = (23 5/8")
  - 300mm = (11 7/8")
- ▼ Phone Line / Fax
  - ▼ Internet connection
  - ▼ Outlet
  - ▼ Main Drop (point of distrution)
- Wire running under carpet

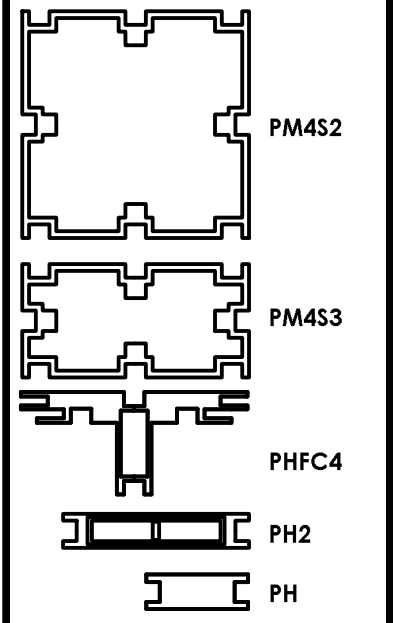

# SET UP INSTRUCTIONS

## SET UP INSTRUCTIONS:

1. CONNECT BOTTOM AND TOP TUBES FOLLOWING THE LABELS
2. CONNECT SIDE TUBES
3. CLEAN THE FRAME AND PLACE THEM ON CLEAN PLACE
4. CAREFULLY REMOVE FABRIC COVER FROM BAG
5. PLACE COVER AROUND THE BOTTOM OF THE FRAME
6. PULL COVER CAREFULLY UP TO THE TOP
7. CLOSE ALL ZIPPERS
8. ADJUST FABRIC AROUND THE FRAME
9. CONNECT CABLE HARNESS TO THE EYEBOLTS
10. COMPLETELY TIGHTEN THREADED CONNECTORS

## BREAK DOWN INSTRUCTIONS:

REVERSE SET-UP STEPS TO BREAKDOWN FRAME

## FABRIC CARE INSTRUCTIONS:

1. UNZIP COVER ZIPPERS
2. CAREFULLY REMOVE FABRIC COVER
3. CLOSE ALL ZIPPERS
4. FOLD OR ROLL NEATLY
5. PLACE FABRIC IN COVER BAG

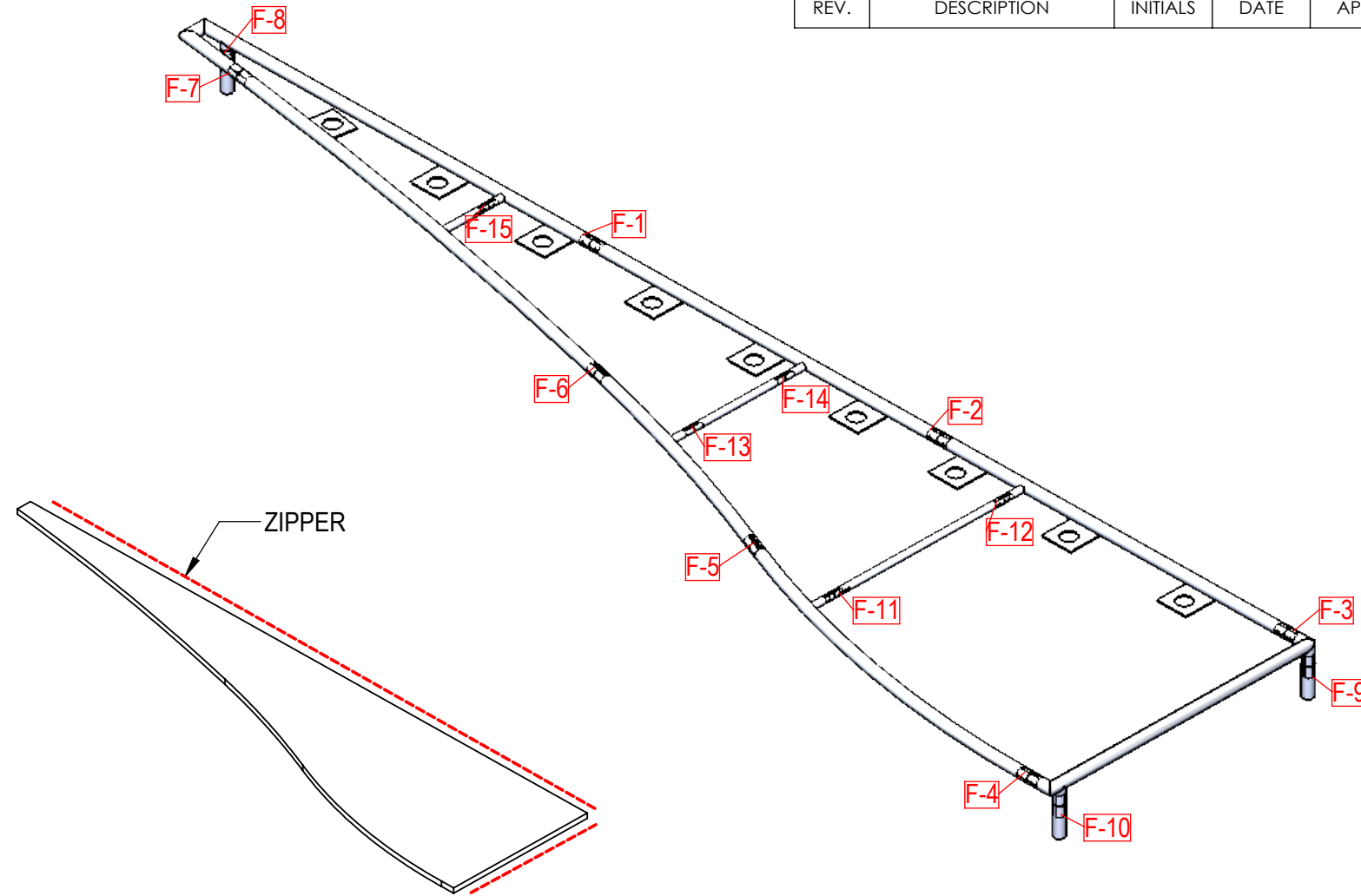

REVISIONS				
REV.	DESCRIPTION	INITIALS	DATE	APPROVED

2400mm = (94 1/2")	▼ Phone Line / Fax
2100mm = (82 5/8")	▼ Internet connection
1800mm = (70 7/8")	▼ Outlet
1500mm = (59")	▼ Main Drop (point of distrution)
1200mm = (47 1/4")	--- Wire running under carpet
900mm = (35 1/2")	
600mm = (23 5/8")	
300mm = (11 7/8")	

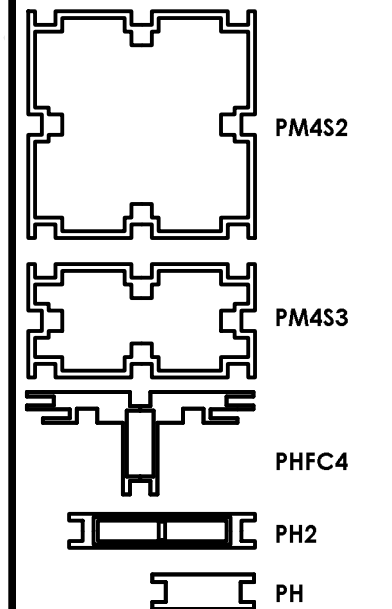

STEP #1:  
SLIDE THE JOINER INTO THE TUBING SO THE THE HEX SCREW SITS IN THE HOLE ON THE TUBINGER

STEP #2:  
TIGHTEN THE HEX SCREW SO THE JOINER SEPERATES AND TIGHTENS AGAINST THE INSIDE OF THE TUBING, LOCKING THE JOINER AND TUBING TOGETHER

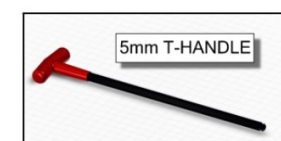
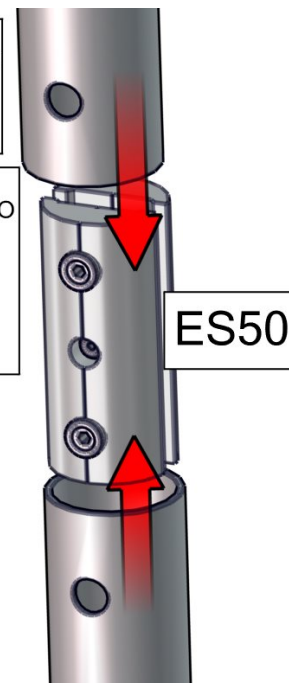

STEP #1:  
SLIDE THE JOINER INTO THE TUBING SO THE THE HEX SCREW SITS IN THE HOLE ON THE TUBINGER

STEP #2:  
TIGHTEN THE HEX SCREW SO THE JOINER SEPERATES AND TIGHTENS AGAINST THE INSIDE OF THE TUBING, LOCKING THE JOINER AND TUBING TOGETHER

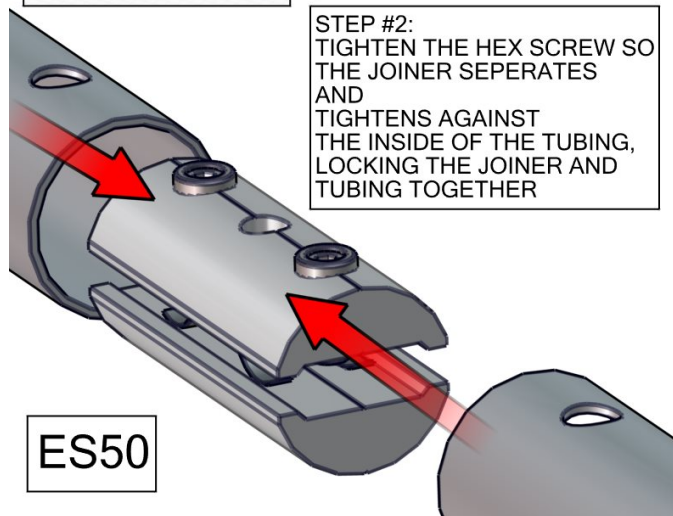

PART NUMBER	DESCRIPTION	QTY.
1085543-F-T1	50mm ANODIZED TUBE	1
1085543-F-T2	50mm ANODIZED TUBE	1
1085543-F-T3	50mm ANODIZED TUBE	1
1085543-F-T4	50mm ANODIZED TUBE	1
1085543-F-T5	50mm ANODIZED TUBE	1
1085543-F-T6	50mm ANODIZED TUBE	1
1085543-F-T7	50mm ANODIZED TUBE	1
1085543-F-T8	30mm ANODIZED TUBE	1
1085543-F-T9	30mm ANODIZED TUBE	1
1085543-F-T10	50mm ANODIZED TUBE	3
1085543-F-G	GRAPHIC FABRIC	1
ES50	EXPANDING SPIGOT FOR 50MM TUBE WITH TENSION PLATE	10
ES30	EXPANDING SPIGOT FOR 30MM TUBE	5
RLFA-WW3W-P45	WW3W SPRING PUCK LIGHT	9

Code	#	Description
CSF	1	CUSTOM FABRIC STRUCTURE

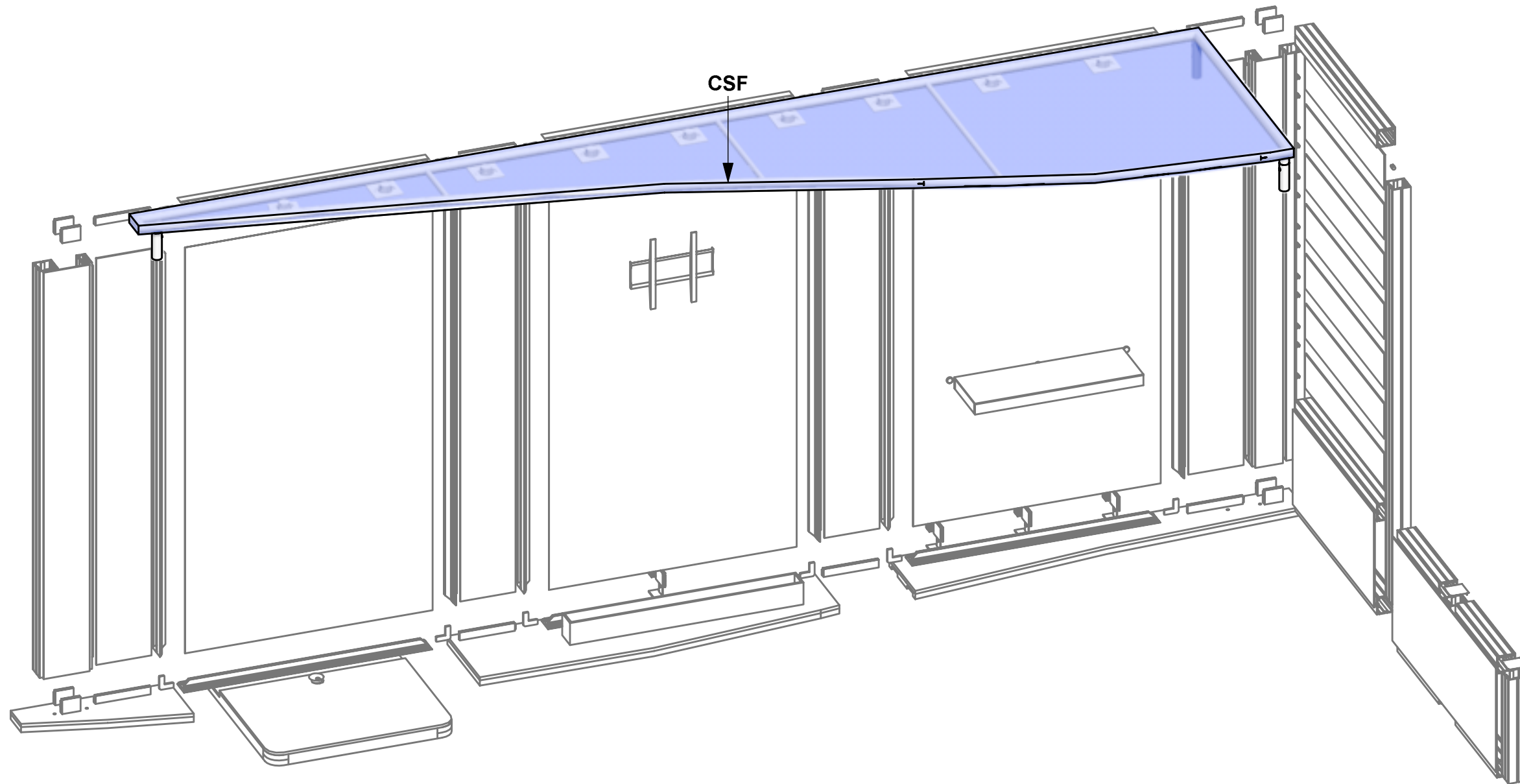

- 2400mm = (94 1/2")
  - 2100mm = (82 5/8")
  - 1800mm = (70 7/8")
  - 1500mm = (59")
  - 1200mm = (47 1/4")
  - 900mm = (35 1/2")
  - 600mm = (23 5/8")
  - 300mm = (11 7/8")
- ▼ Phone Line / Fax
  - ⬇ Internet connection
  - ⬇ Outlet
  - ⬇ Main Drop (point of distrution)
  - Wire running under carpet

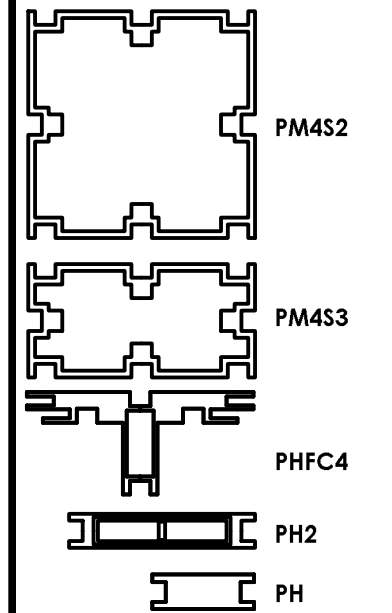

Code	#	Description
CUS-CTR- 1	1	**CNC** 48"w x 14.5"d x 40"h laminate reception cou

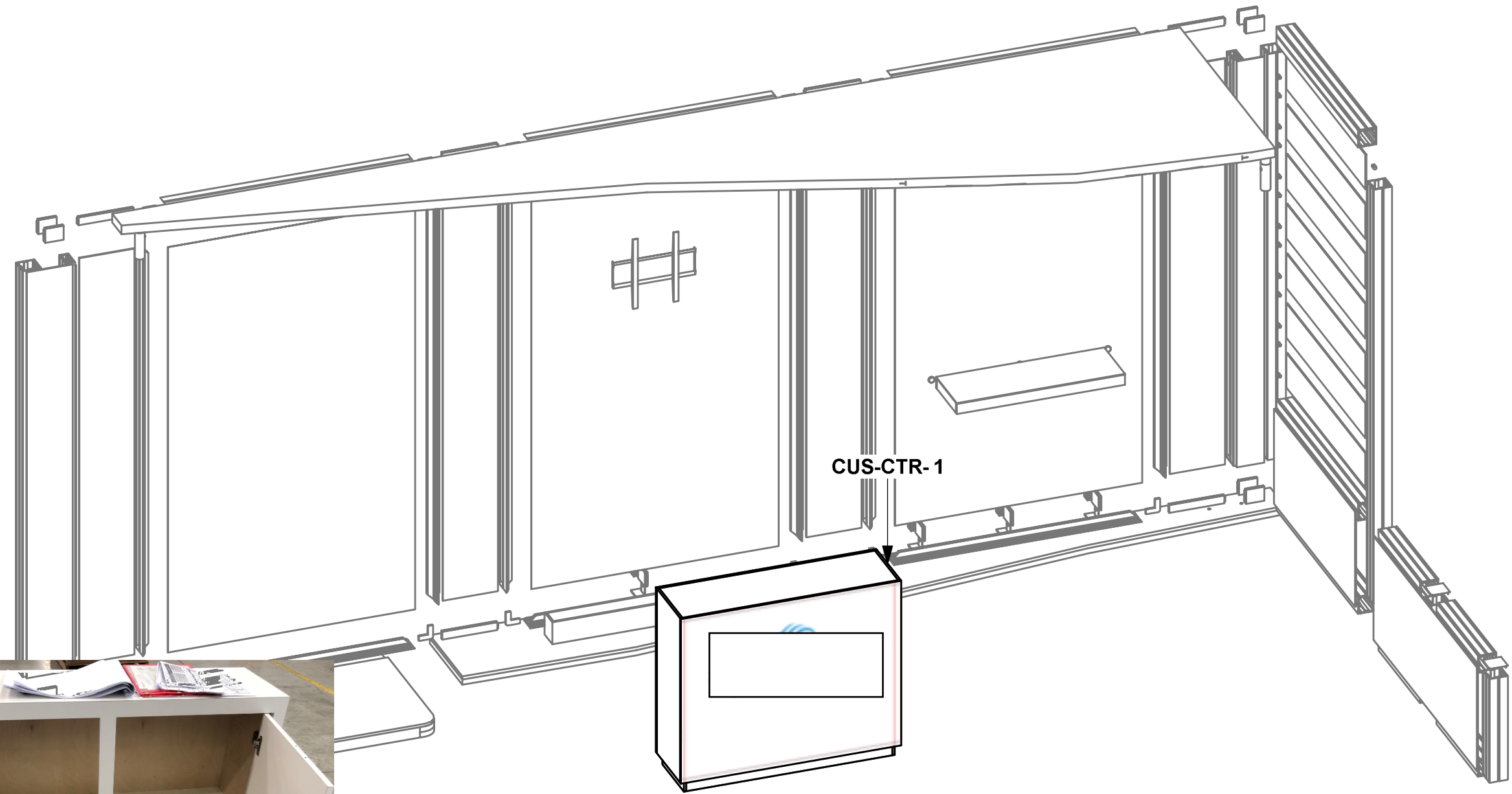

- 2400mm = (94 1/2") Phone Line / Fax
  - 2100mm = (82 5/8") Internet connection
  - 1800mm = (70 7/8") Outlet
  - 1500mm = (59") Main Drop (point of distrution)
  - 1200mm = (47 1/4")
  - 900mm = (35 1/2")
  - 600mm = (23 5/8")
  - 300mm = (11 7/8")
- Wire running under carpet

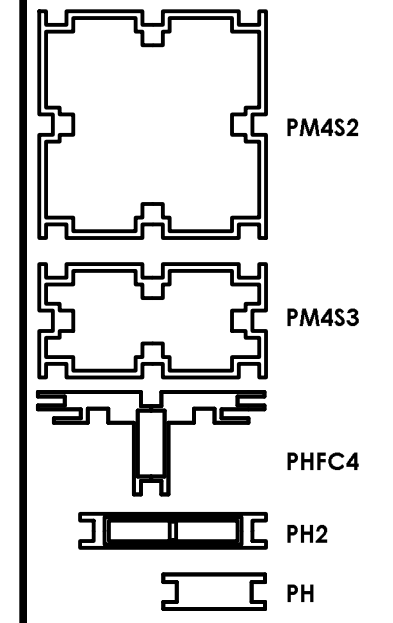

Precise Adjustment of  
Nitrous Concentration  
Between 0% and 70%

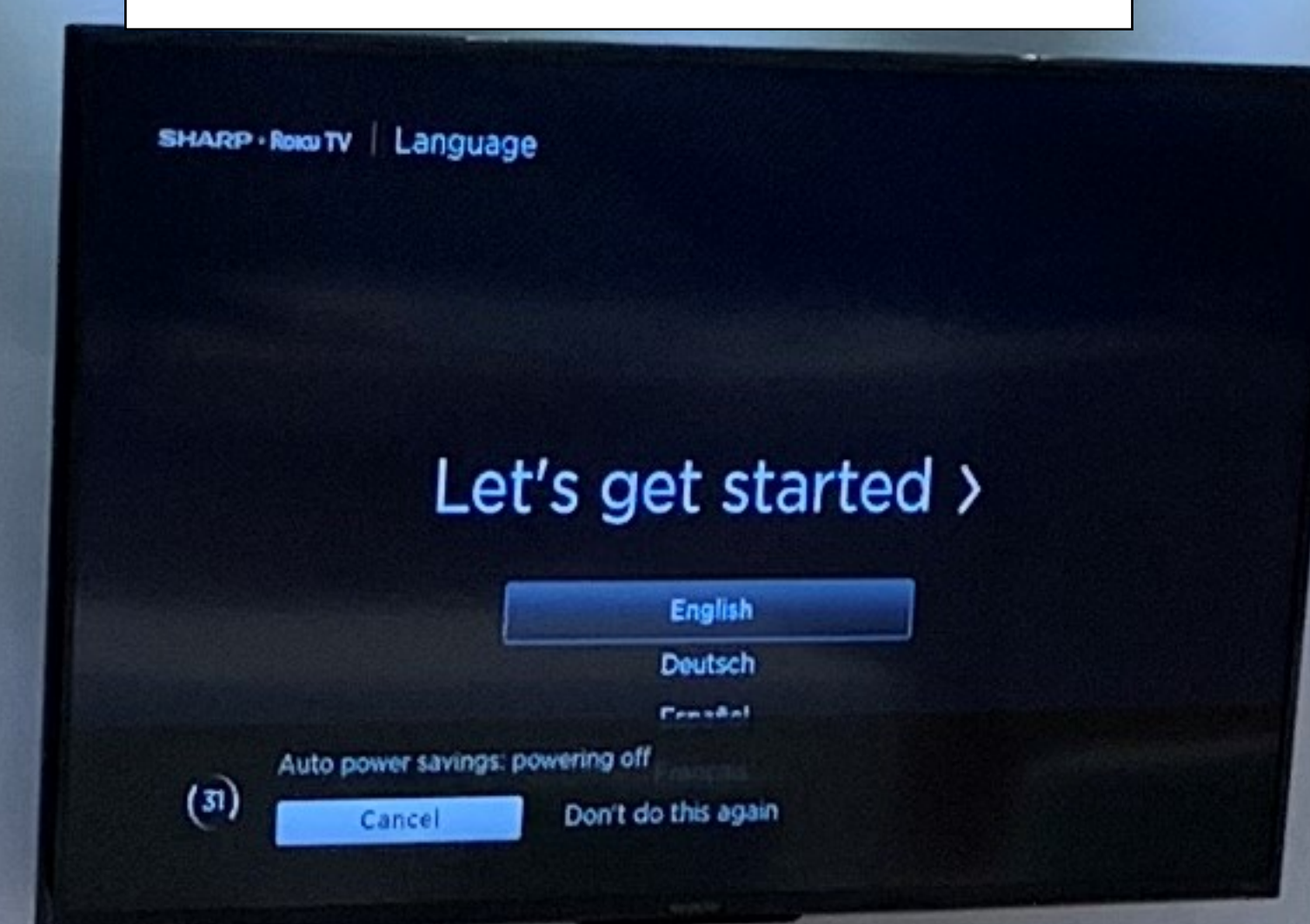

Evacuator Available!





# **PACKING INSTRUCTIONS**



Code	#
A3	7
A17	1
CKAPS	28
A1	1
A2	3
A9	2
PM4S2-MCAP	2
A4	2
A5	4
A6	6
CB9	12
A7	6
AB	8
WME-2259	8
A10	2
A11	16
A12	1
MM-M-T	1
A13	4
CUS-SW-FOOT-500-LN	1
SD-1 1/4 D CAP-1/2	3
CUS-SW-FOOT-500-LN	3
A14	3
GRAPHIC( C1 )	1
GRAPHIC( C2 )	1
GRAPHIC( C3 )	1
GRAPHIC( A1 )	1
GRAPHIC( B1 )	1
GRAPHIC( B2 )	1
GRAPHIC( B3 )	1
GRAPHIC( B4 )	1
GRAPHIC( D1 )	1
GROMMET-CAP-RNG-WHT	1
A16	1
CUS-WOOD-ITEM-6	1
CSF	1
PANEL 2	1
PANEL 4	1
C1	1
PANEL 1	1
PANEL 3	1



# CASE # 1

LEGEND	
	GREY FOAM FOLDED TO FILL EMPTY SPACES OR USED AS PROTECTION
	1/2" CARDBOARD SPACER (PUT IN BETWEEN EVERY PANEL)
	DIVIDER
	1/4" WHITE FOAM (USED AS PROTECTION - DOOR PANELS, W/LOCKS)





## CASE # 2





LEGEND	
	GREY FOAM FOLDED TO FILL EMPTY SPACES OR USED AS PROTECTION
	1/2" CARDBOARD SPACER (PUT IN BETWEEN EVERY PANEL)
	DIVIDER
	1/4" WHITE FOAM (USED AS PROTECTION DOOR PANELS W/LOCKS)





skid # 3



LEGEND	
	GREY FOAM FOLDED TO FILL EMPTY SPACES OR USED AS PROTECTION
	1/2" CARDBOARD SPACER (PUT IN BETWEEN EVERY PANEL)
	DIVIDER
	1/4" WHITE FOAM (USED AS PROTECTION DOOR PANELS W/LOCKS)

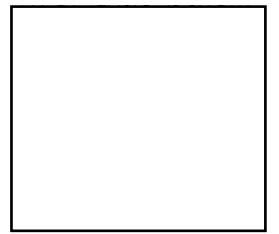
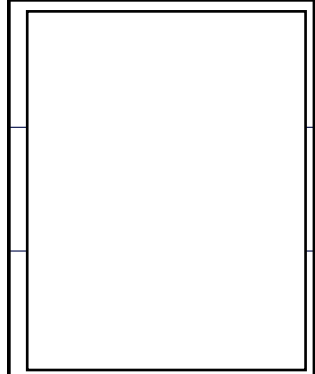
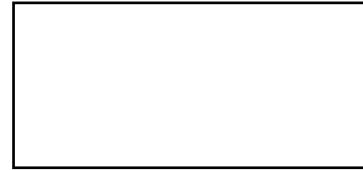
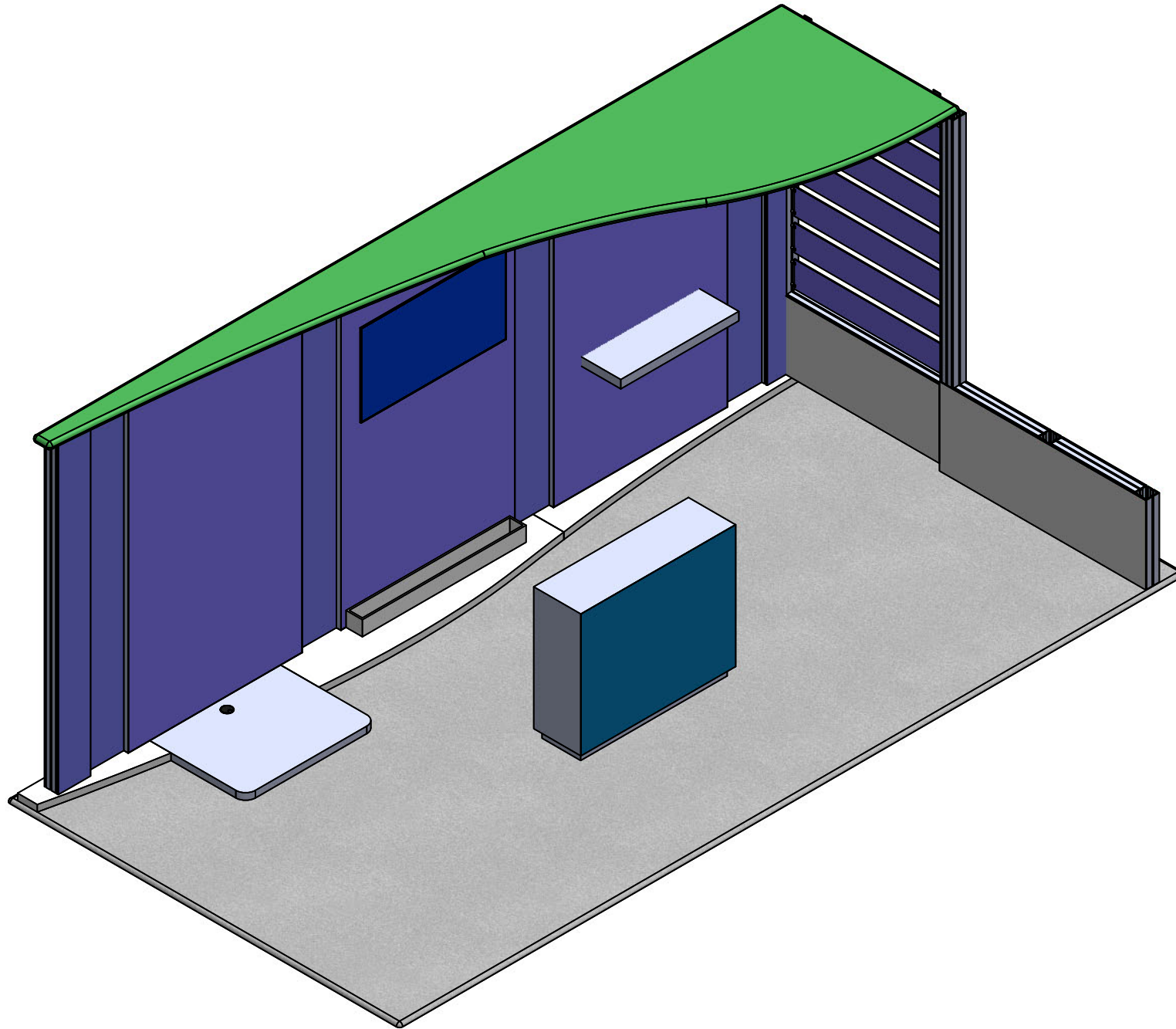

**GRAPHIC LAYOUT**



### **ACCEPTABLE FILE FORMATS**

Illustrator CC or below  
Photoshop CC or below or InDesign CC or below (not preferred)

High quality, editable PDFs, Photoshop and Illustrator files are preferred, as they are more suitable applications for large format printing. Art time will be charged if files need to be fixed or altered to meet guidelines. When sending files, please be sure to include all support art (fonts, linked images, etc).

Please note that Illustrator special effects such as glows, transparencies, or drop shadows are not recommended. These effects sometimes have unpredictable results when printing. Photoshop is preferred when using these special effects.

### **FONT SPECIFICATIONS**

Fonts must be converted to outlines. If fonts are not created to outlines, please provide Macintosh or TrueType fonts. If changes need to be made in the file, please provide the fonts and a version of the file with editable type.

### **COLOR SPECIFICATIONS**

Please provide all vector files (Illustrator and InDesign) in CMYK format. Please supply all raster artwork (Photoshop files, jpgs, tiffs) in RGB format for the most accurate color output. Please provide a hard copy proof of the files being printed for color accuracy and a PDF layout for file layout accuracy.

If Pantone colors need to be matched please specify on purchase order or hard copy reference. All critical Pantone colors need to be called out in the file as solid coated swatches. If multiple Pantone swatches are used in the file, all will be matched to solid coated unless otherwise specified.

Please feel free to submit catalogs, brochures, printed proofs, etc. to use for a color reference. If color matching is required for Photoshop files please provide a layered file. Art time may be charged to correct flattened Photoshop files.

If color matching to existing graphics, we will need those back to review. Please contact your sales representative for a case number.

We guarantee color matching on all hard copy proofs, specified Pantone colors and client-supplied hard copy proofs. Orders without indication of Pantone colors, supplied hard copy proofs or requested hard copy proofs are not guaranteed for color.

### **RESOLUTION**

All raster files (either print files or linked files) must be at 100-120 pixels per inch at 100%.

### **VINYL CUT GRAPHICS**

Artwork must be set-up as vector files with fonts created to outlines for all cut vinyl. Please specify Avery color number for solid color vinyl or PMS color for dsG printed and cut vinyl.

### **SUBMITTING ARTWORK FILES**

Files are accepted via Email (up to 5MB), FTP site, DVD, CD or File transfer site such as WeTransfer or Hightail.

Files can be uploaded to:  
[www.handbookart.com](http://www.handbookart.com)

Please reference the FTPsite guidelines for more information.

### **MURALS | POPUP GRAPHICS**

Coyote™ mural files must be built as one file. Please note where panel breaks are located and try to minimize the amount of type that crosses over the panel breaks.

### **BLEED SPECIFICATIONS**

All graphics produced require specific bleeds.

Below is a general outline for the required bleeds. Mural Popup Files - 1/2" bleed around the perimeter.

Hopups™, Formulates™, Vector Frame™ - 2" bleed around the perimeter. Please keep all logos, type, and critical information at least 2" in from the visual edge of the graphic.

Fabric Structures - 5" bleed around the perimeter.

Banner Stand Graphics - each product has specific bleed requirements. Please refer to graphic template for specific information. Different printing processes may require different bleeds. All banner stand graphics printed on 8oz. Oxford will require an extra 1" bleed around the perimeter.

Custom Dye-Sub Flag Graphics - 2" bleed left & right sides, 4" bleed top & bottom.

Orbital Express™ Truss Graphics, UV- 1/2" bleed around the perimeter.

Orbital Express™ Truss Graphics, 8oz. Oxford - 2" bleed around the perimeter.

Custom Contour Cut UV Graphics - 1/2" bleed around the perimeter.

Custom Dye-Sub Graphics - 2" bleed around the perimeter

Custom Dye-Sub Graphics exceeding 160" - 5" bleed around the perimeter.

Templates for products are available online at  
[www.exhibitorshandbook.com](http://www.exhibitorshandbook.com)

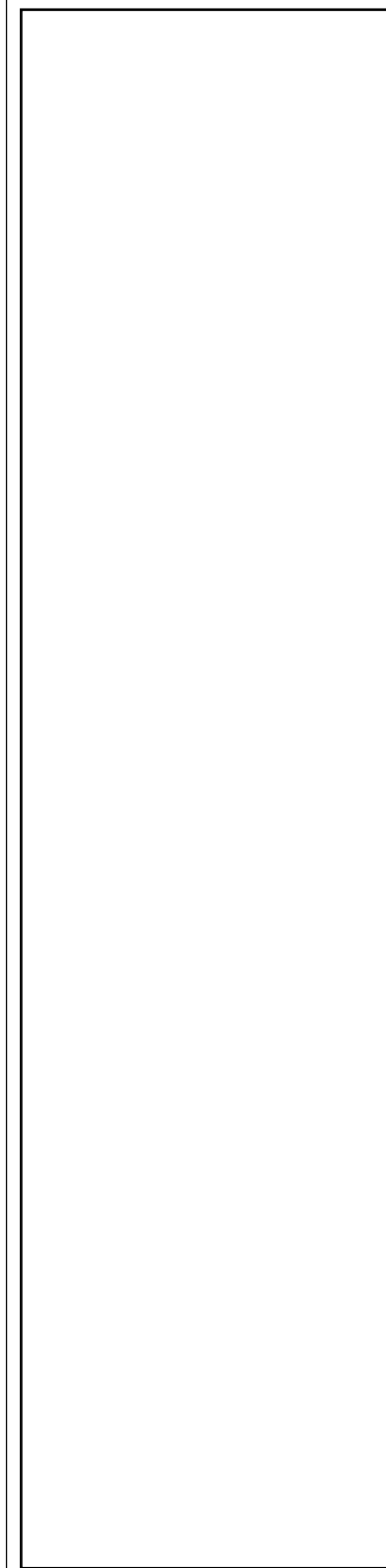
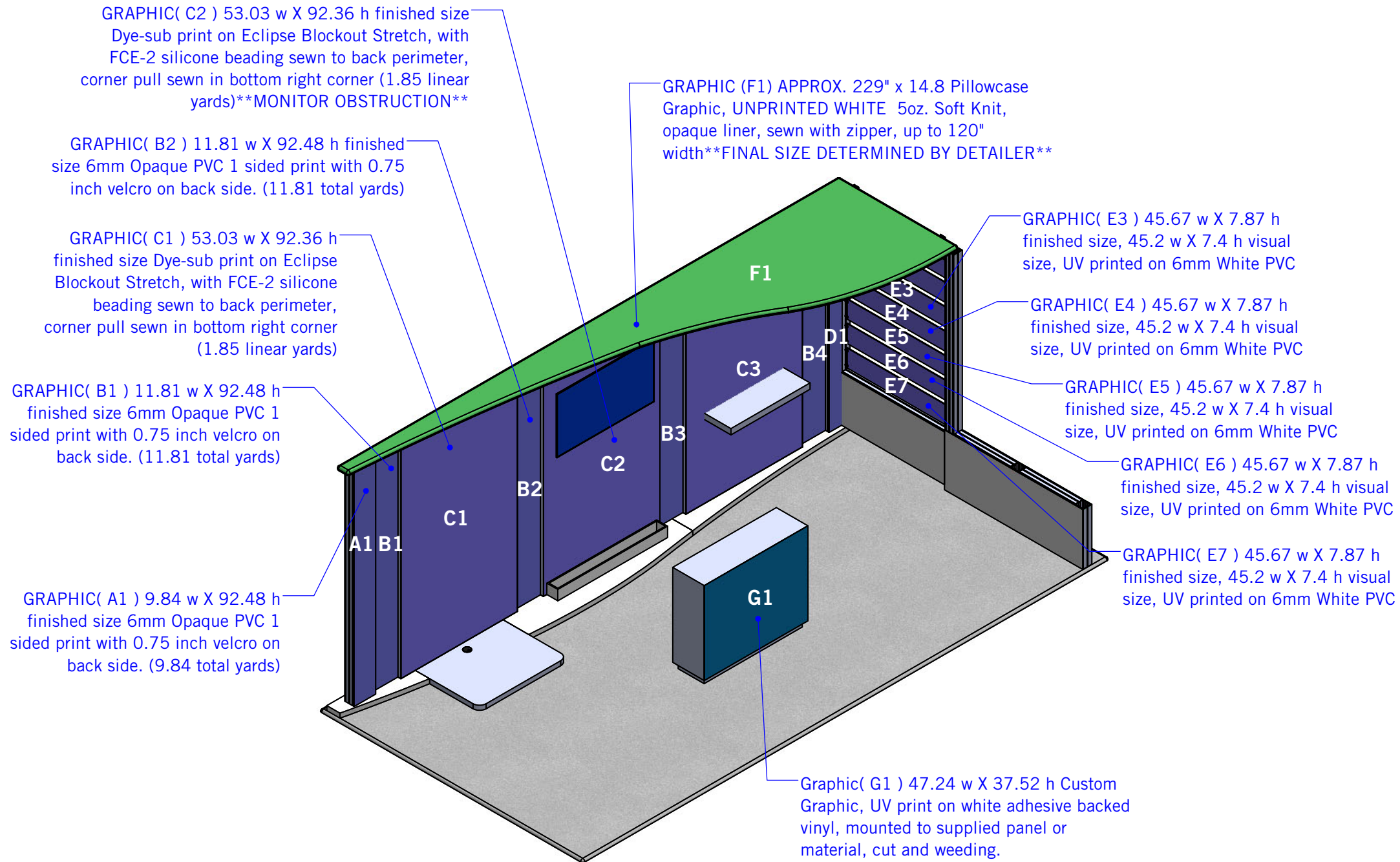

GRAPHIC( B4 ) 11.81 w X 92.48 h finished size 6mm Opaque PVC 1 sided print with 0.75 inch velcro on back side. (11.81 total yards)

GRAPHIC( C3 ) 53.03 w X 92.36 h finished size Dye-sub print on Eclipse Blockout Stretch, with FCE-2 silicone beading sewn to back perimeter, corner pull sewn in bottom right corner (1.85 linear yards)\*\*SHELF OBSTRUCTION\*\*

GRAPHIC( B3 ) 11.81 w X 92.48 h finished size 6mm Opaque PVC 1 sided print with 0.75 inch velcro on back side. (11.81 total yards)

GRAPHIC( D1 ) 5.91 w X 92.48 h finished size 6mm Opaque PVC 1 sided print with 0.75 inch velcro on back side. (5.91 total yards)

GRAPHIC( E1 ) 45.67 w X 7.87 h finished size, 45.2 w X 7.4 h visual size, UV printed on 6mm White PVC

GRAPHIC( E2 ) 45.67 w X 7.87 h finished size, 45.2 w X 7.4 h visual size, UV printed on 6mm White PVC

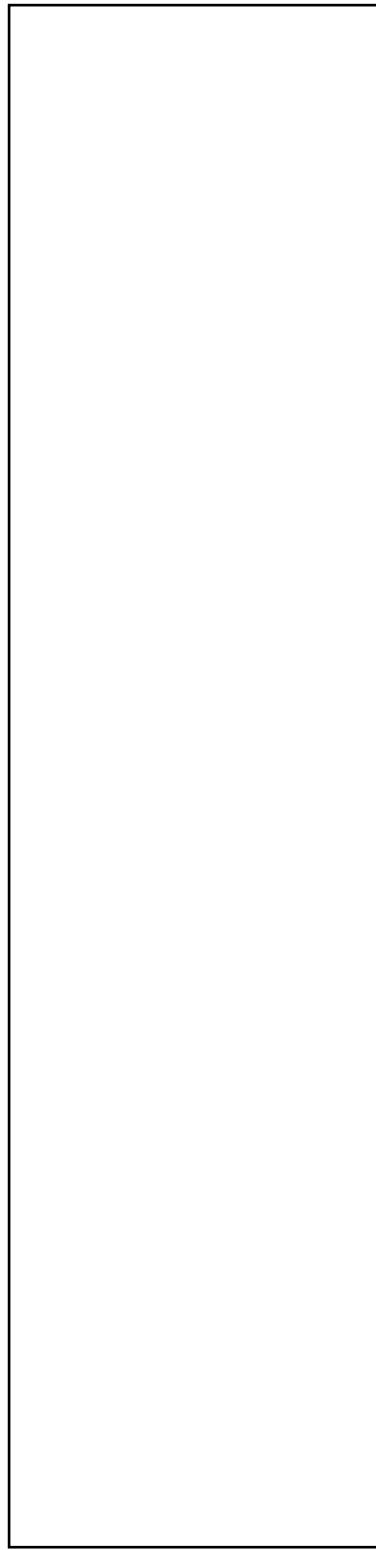
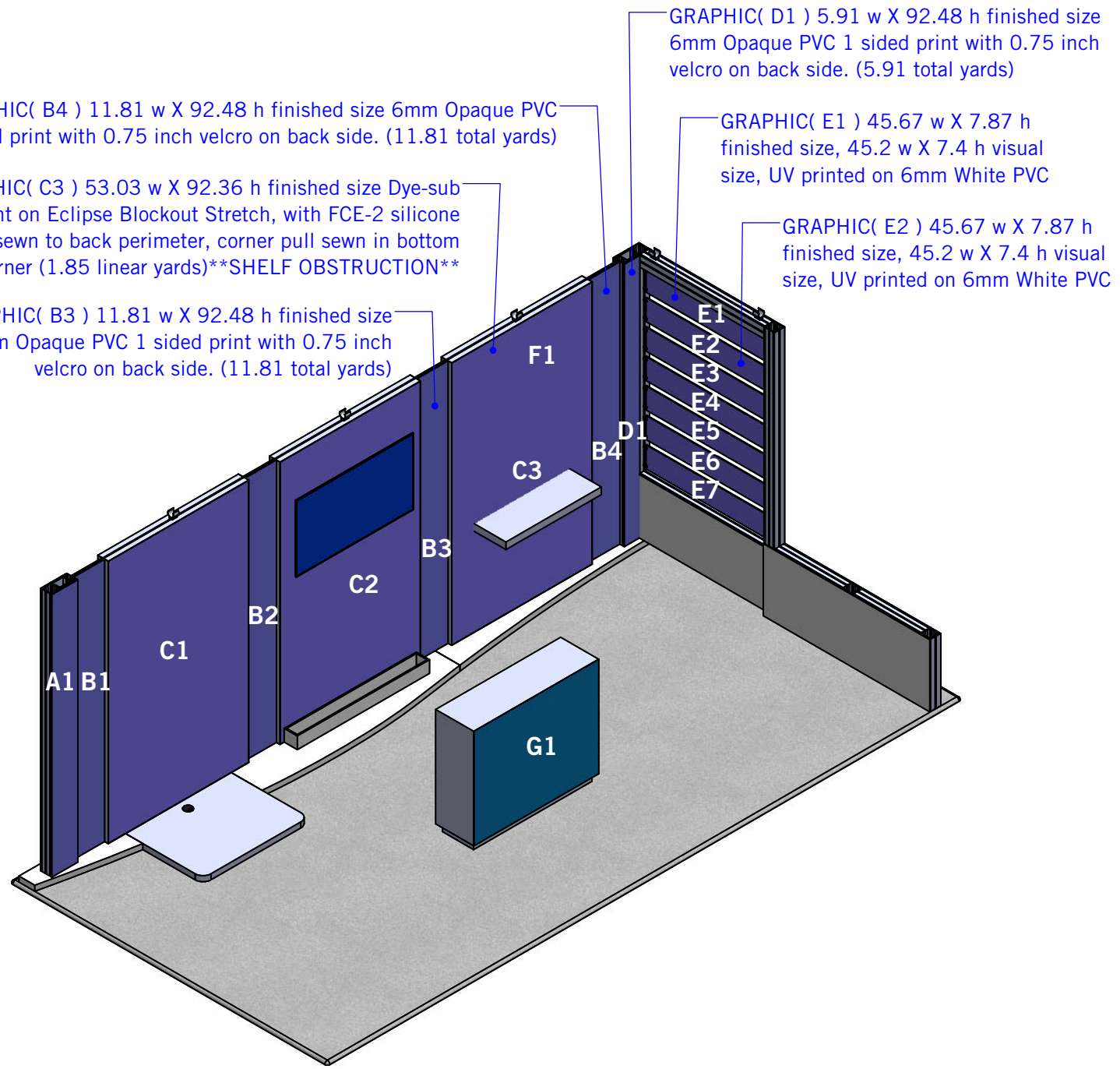



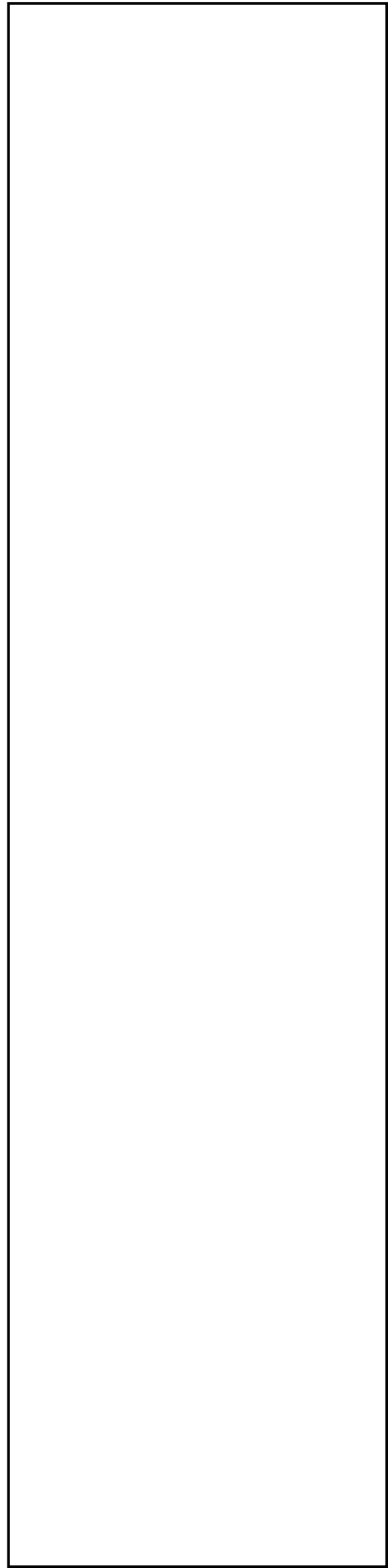
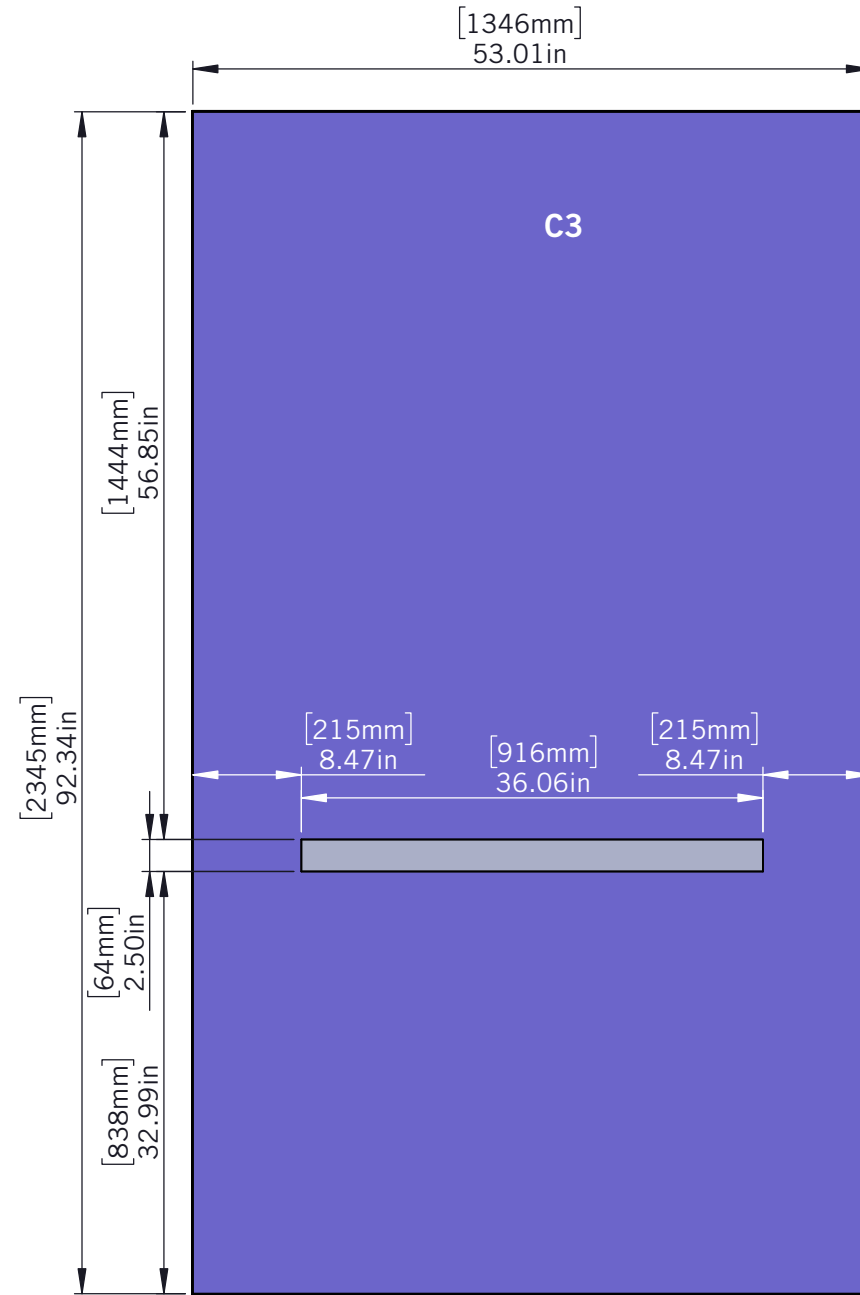
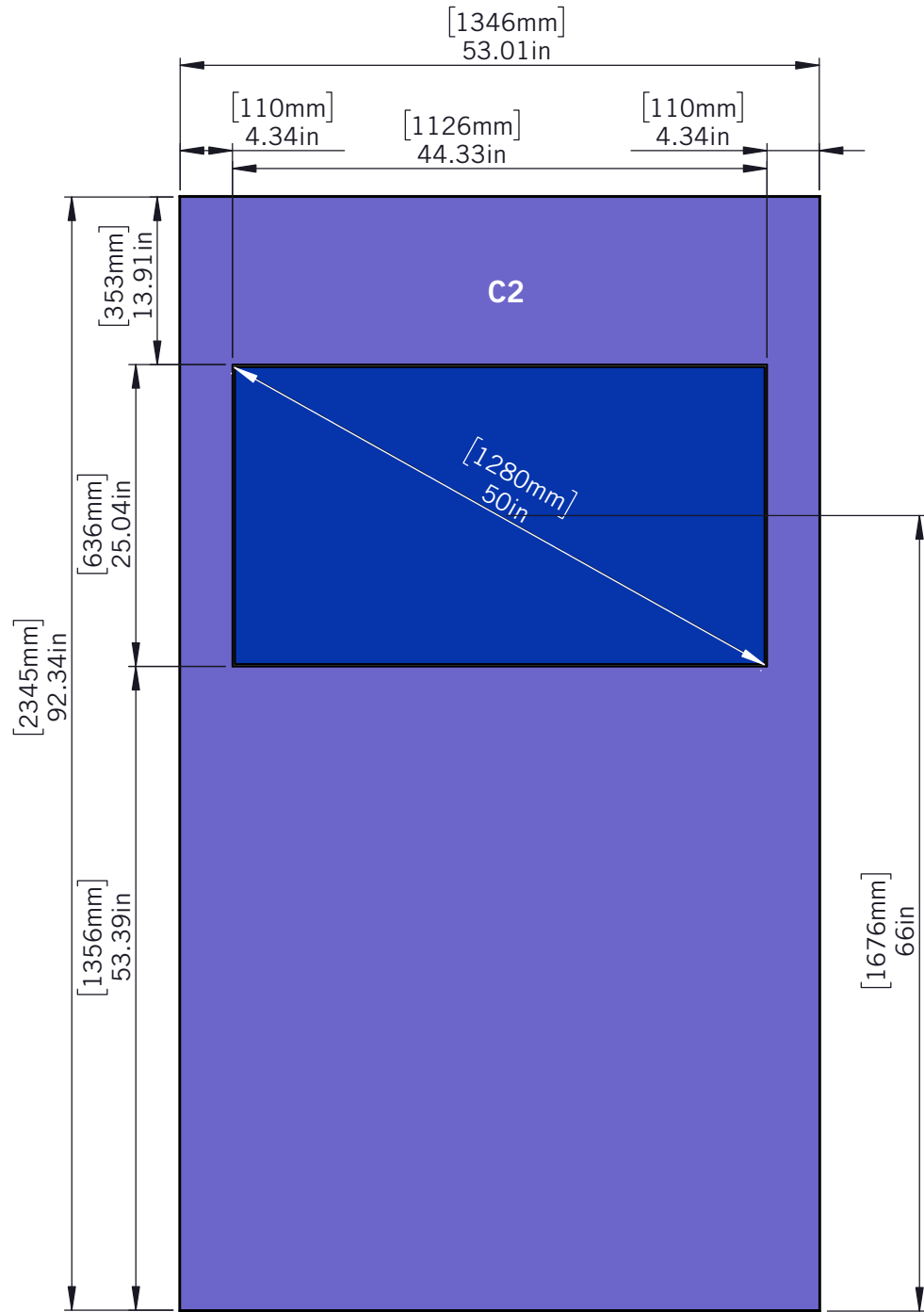

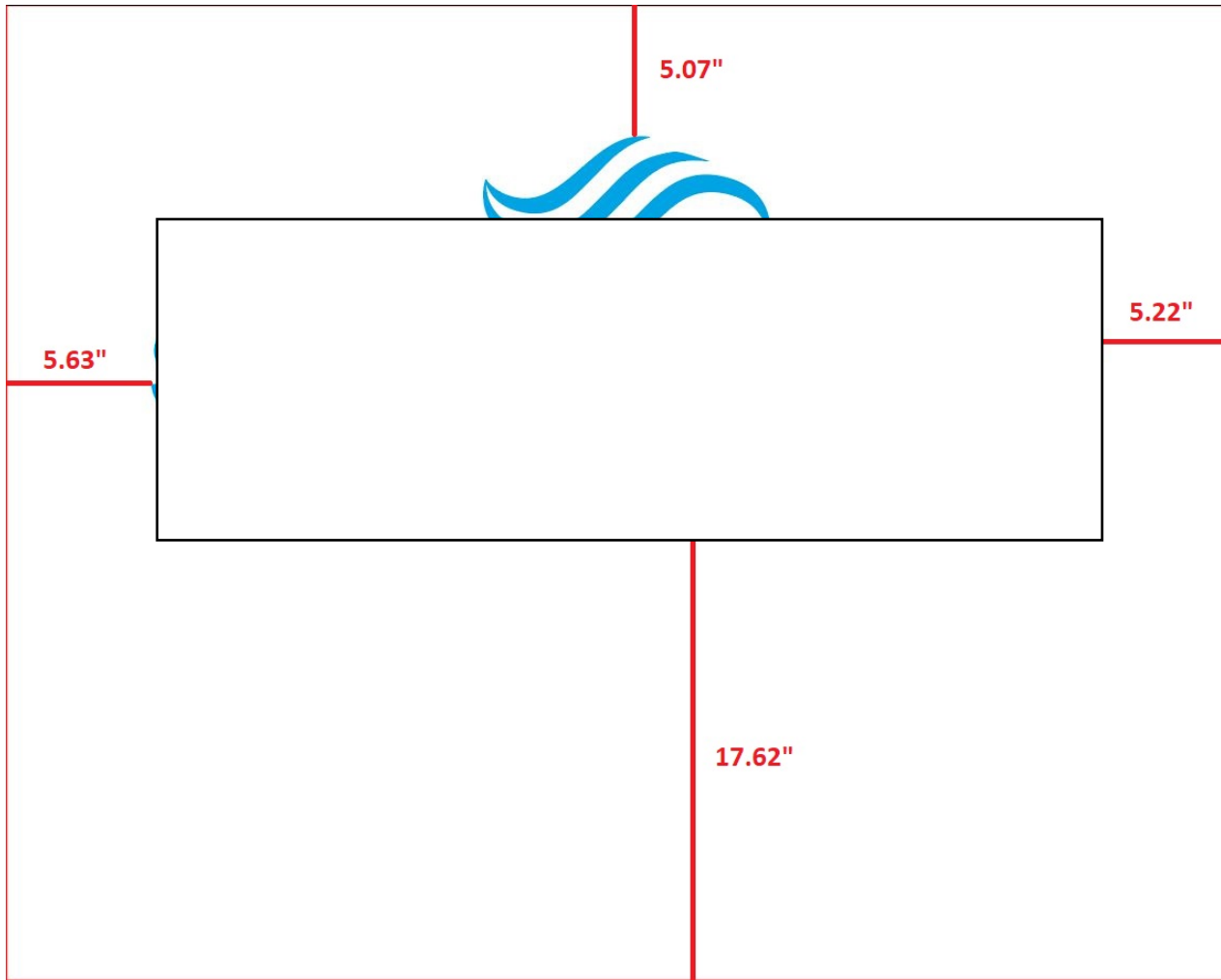

<input type="text"/>			
Product Description:	Custom Graphic, UV print on white adhesive backed vinyl, mounted to supplied panel or material		
Product:	C-G-W-AVP-SM - CUSTOM SQ FT GFX	Quantity:	1
Special Notes:	Graphic( G1 ) (37.4"w x 15.855"h total size) 36.4"w x 14.855"h - cutpath - mounted to counter that is 47.25"w x 37.5"h see proof for placement of logo on panel.	Special Finishing:	Custom Graphic, UV print on white adhesive backed vinyl, mounted to supplied panel or material, cut and weeding.
PMS Colors:	NONE	File Name:	1085543_G1_Printx1



Product Description:	Custom Graphic, UV print on 6mm White PVC, single sided, up to 4' X 8'		
Product:	C-G-W-PVC-6 - CUSTOM SQ FT GFX	Quantity:	4
Special Notes:	GRAPHIC (B1-B4) - (12.81"w x 93.48"h total size) 11.81 w X 92.48 h finished size - cutpath	Special Finishing:	6mm Opaque PVC 1 sided print with 0.75 inch velcro on back side.
PMS Colors:	NONE	File Name:	1085543_B1-B4_Printx4

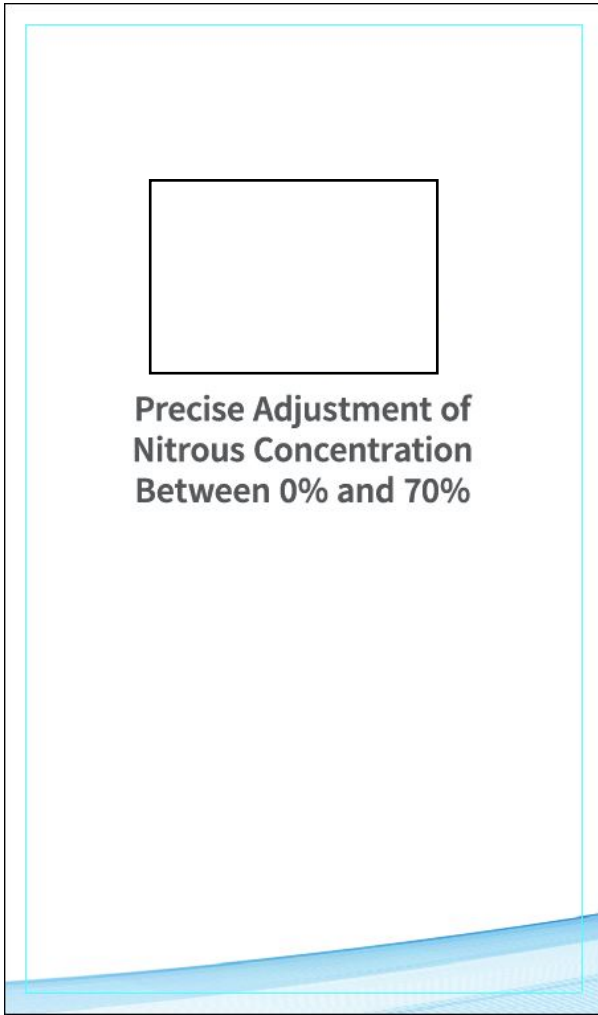

<input type="text"/>			
Product Description:	Custom Graphic, dye-sub print on Eclipse Blockout Stretch, single sided, up to 120" width, sewn with FCE-2 silicone beading around perimeter & pull tab in bottom right corner		
Product:	CUS-G-EBS-SEG - CUSTOM GRAPHIC, ECLIPSE BLOCKOUT STRETCH W/ SEG	Quantity:	1
Special Notes:	GRAPHIC( C1 ) (57.03"w x 96.36"h total size) 53.03 w X 92.36 h finished size - try to align C graphic when on frame (see attached for rough alignment layout)	Special Finishing:	Dye-sub print on Eclipse Blockout Stretch, with FCE-2 silicone beading sewn to back perimeter, corner pull sewn in bottom right corner (1.85 linear yards)
PMS Colors:	281 & 425 - see attached for color locations	File Name:	1085543_C1_Printx1

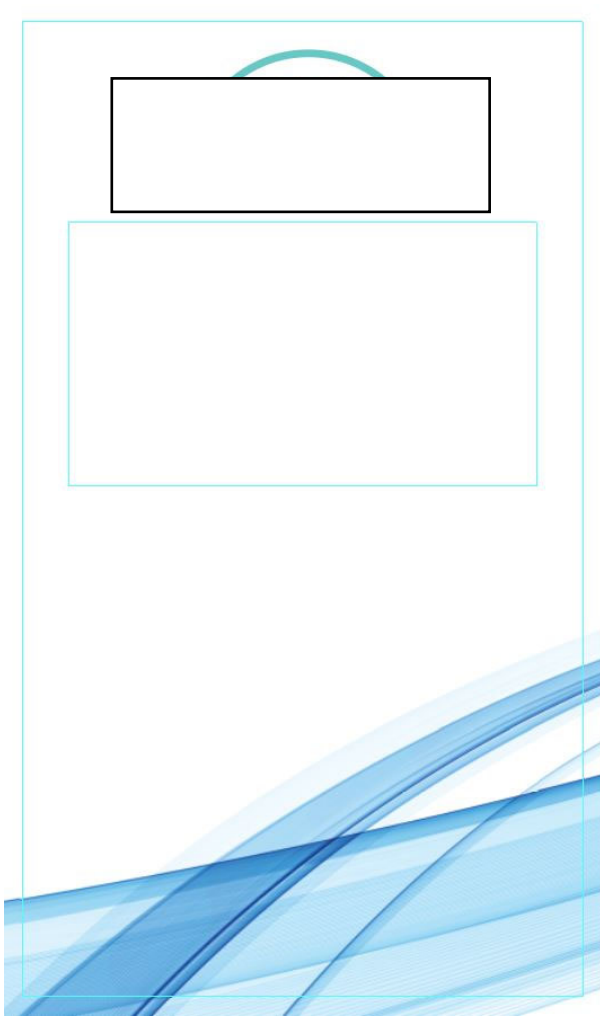

Product Description:	Custom Graphic, dye-sub print on Eclipse Blockout Stretch, single sided, up to 120" width, sewn with FCE-2 silicone beading around perimeter & pull tab in bottom right corner		
Product:	CUS-G-EBS-SEG - CUSTOM GRAPHIC, ECLIPSE BLOCKOUT STRETCH W/ SEG	Quantity:	1
Special Notes:	GRAPHIC( C2 ) 53.03 w X 92.36 h finished size - try to align C graphic when on frame (see attached for rough alignment layout)	Special Finishing:	Dye-sub print on Eclipse Blockout Stretch, with FCE-2 silicone beading sewn to back perimeter, corner pull sewn in bottom right corner (1.85 linear yards)**MONITOR OBSTRUCTION**
PMS Colors:	NONE	File Name:	1085543_C2_Printx1

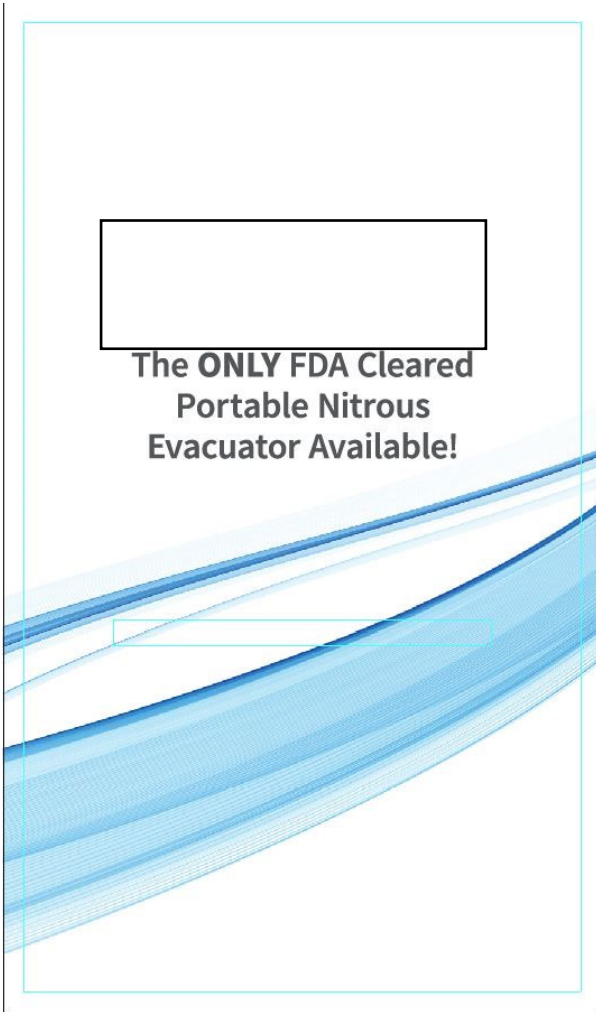

Product Description:	Custom Graphic, dye-sub print on Eclipse Blockout Stretch, single sided, up to 120" width, sewn with FCE-2 silicone beading around perimeter & pull tab in bottom right corner		
Product:	CUS-G-EBS-SEG - CUSTOM GRAPHIC, ECLIPSE BLOCKOUT STRETCH W/ SEG	Quantity:	1
Special Notes:	GRAPHIC( C3 ) (57.03"w x 96.36"h total size) 53.03 w X 92.36 h finished size - try to align C graphics on display (see attached for rough alignment layout)	Special Finishing:	Dye-sub print on Eclipse Blockout Stretch, with FCE-2 silicone beading sewn to back perimeter, corner pull sewn in bottom right corner (1.85 linear yards)**SHELF OBSTRUCTION**
PMS Colors:	425 & 2995	File Name:	1085543_C3_Printx1



10amp 120 Volt Service Single Outlet - Connection

[Edit/View](#)

[✖ Remove](#)

1

±