

BILL OF MATERIALS			
ITEM NO.	PART NUMBER	DESCRIPTION	QTY.
1	73747-01-01	240"W X 120"DX 96"H ES FRAME	1
2	HD IL 07	SPLICE LOCK	20
3	HD CL 06	CORNER LOCK	12
4	HD SL 01	STRAIGHT LOCK	58

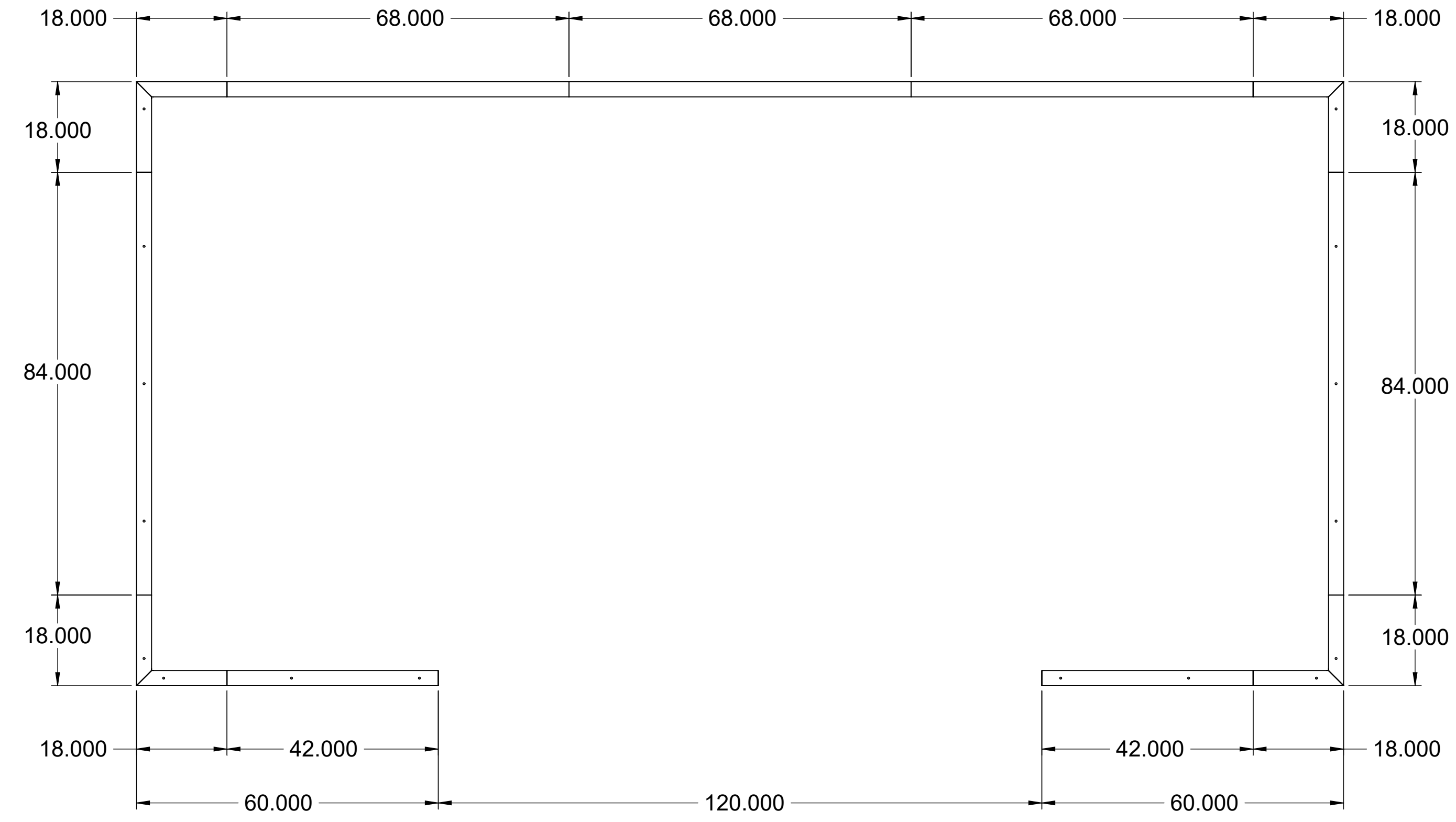

TOP VIEW

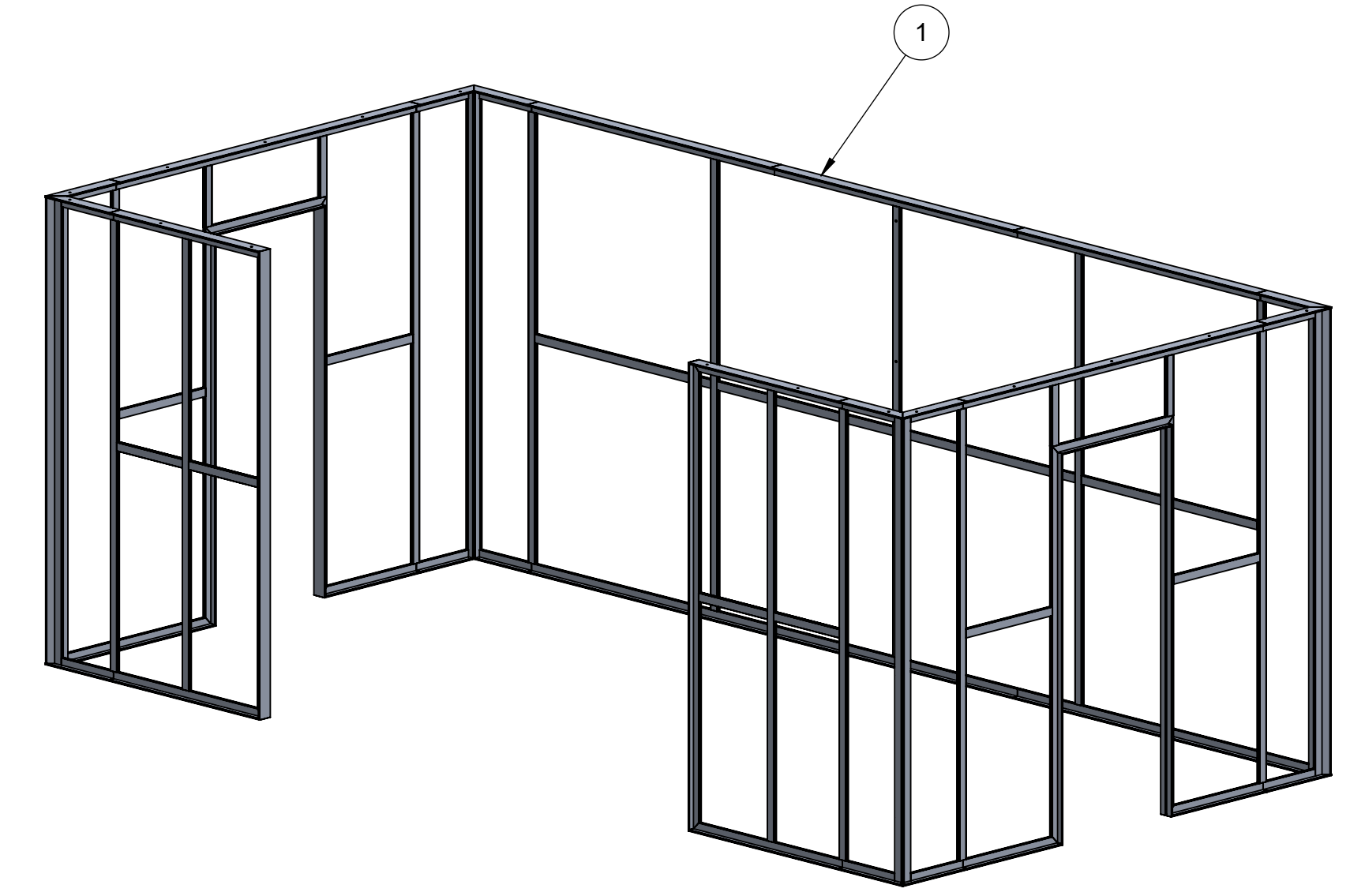

ISOMETRIC VIEW

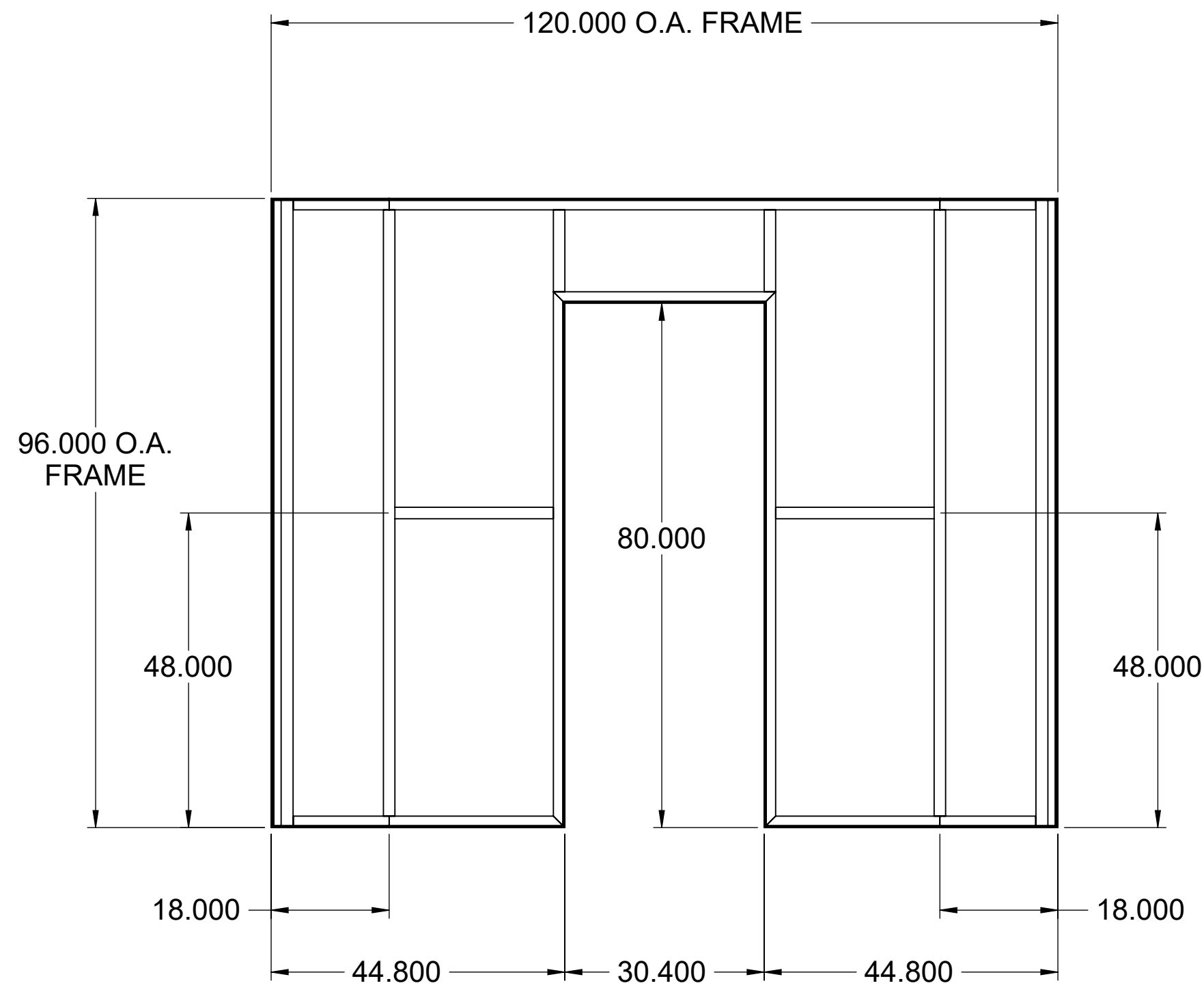

SIDE VIEW

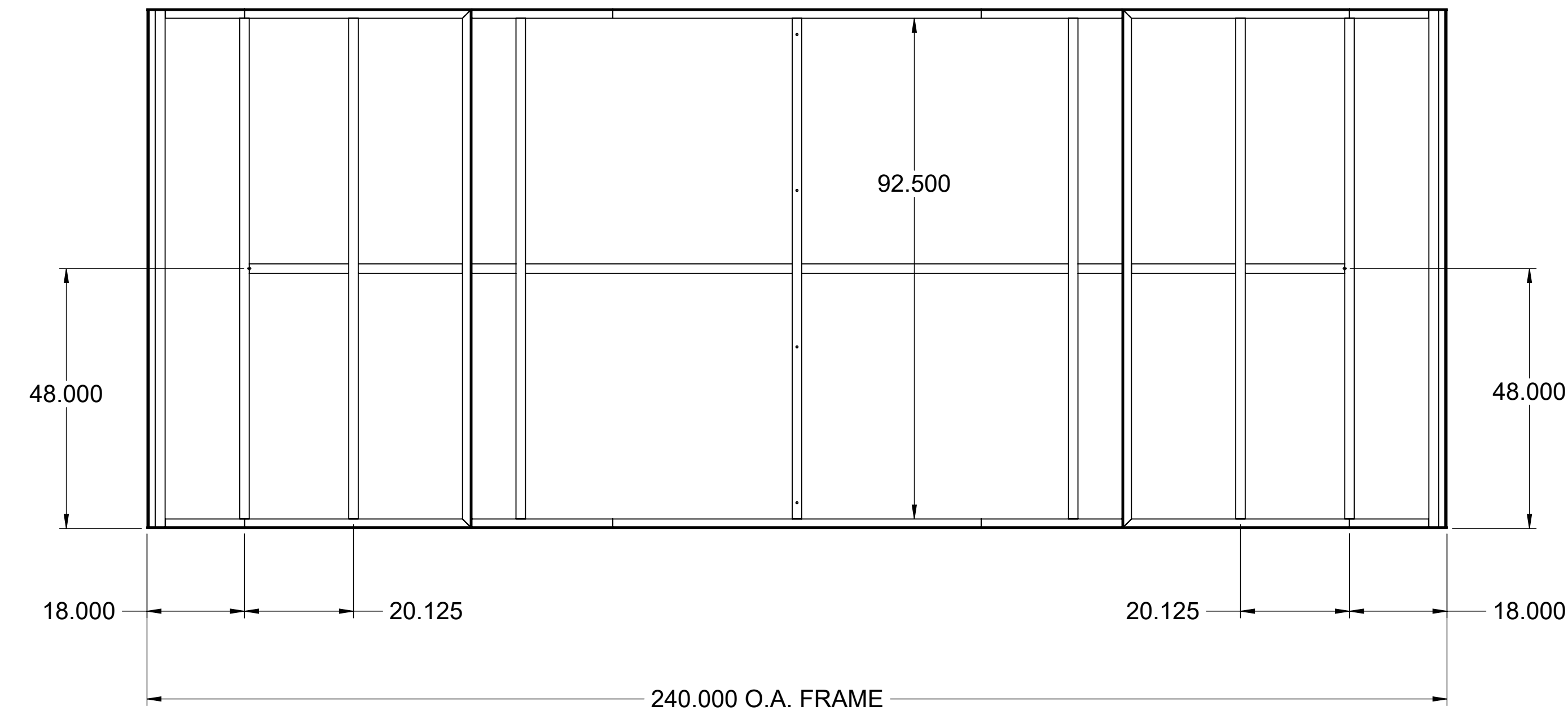

FRONT VIEW

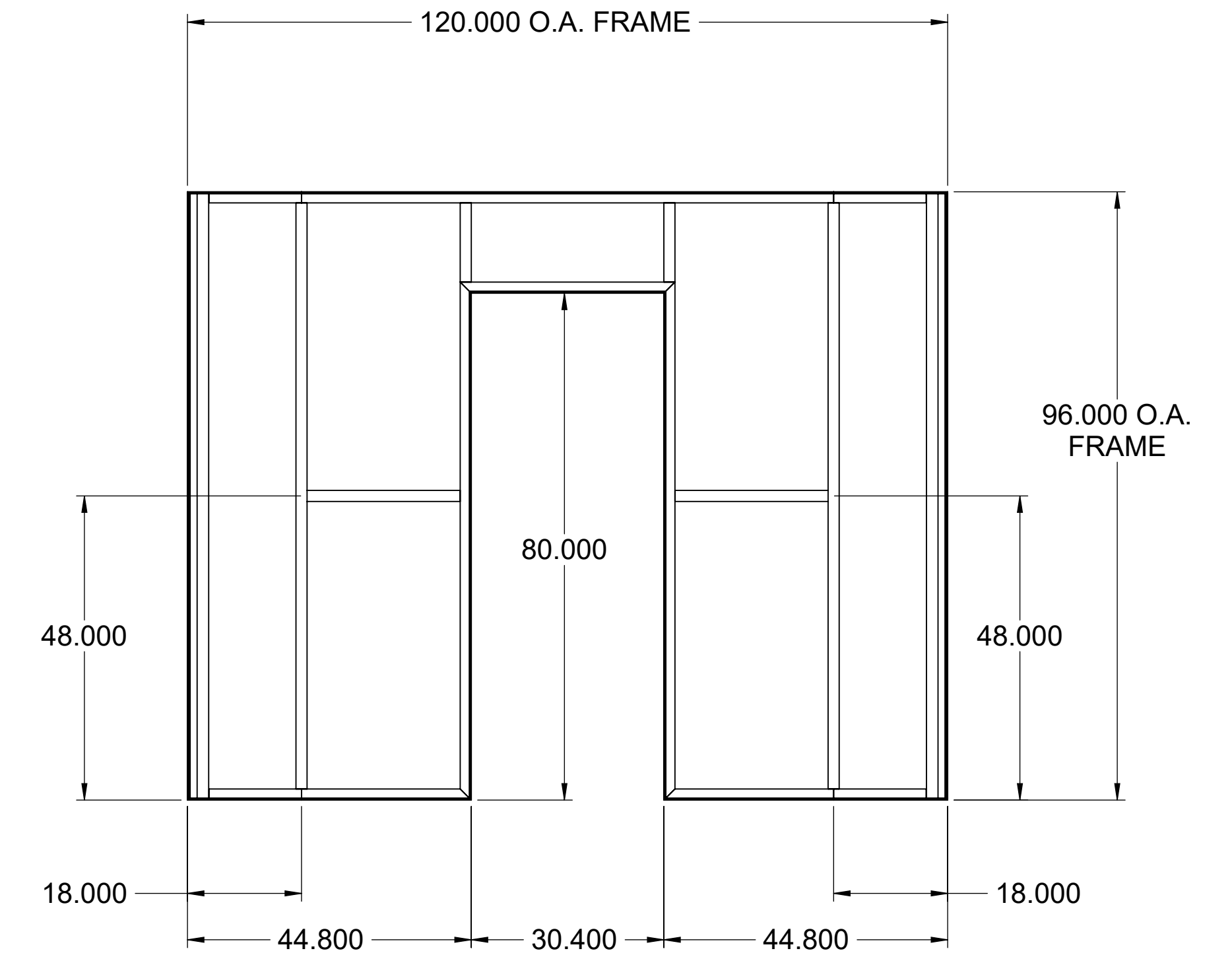

SIDE VIEW

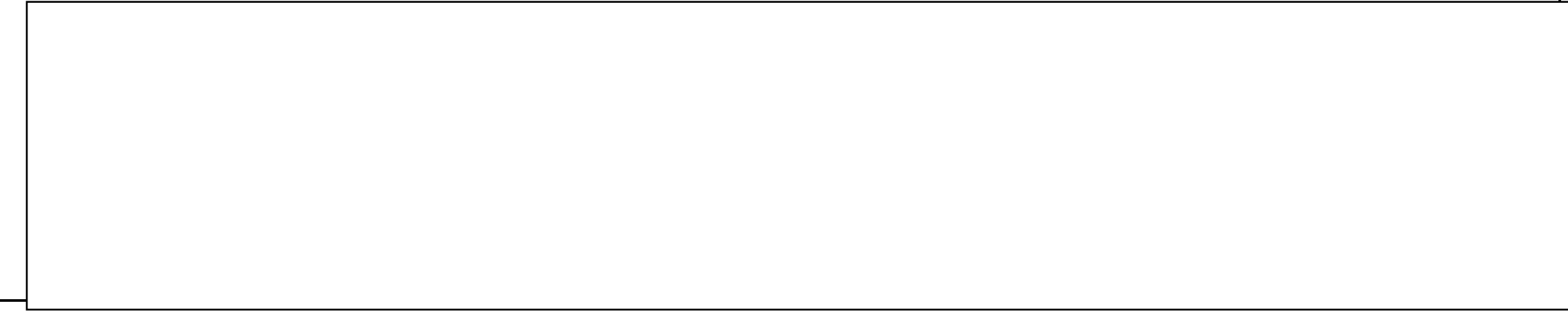

BILL OF MATERIALS			
ITEM NO.	PART NUMBER	DESCRIPTION	QTY.
1	73747-01-01	240"W X 120"DX 96"H ES FRAME	1
2	HD IL 07	SPLICE LOCK	20
3	HD CL 06	CORNER LOCK	12
4	HD SL 01	STRAIGHT LOCK	58

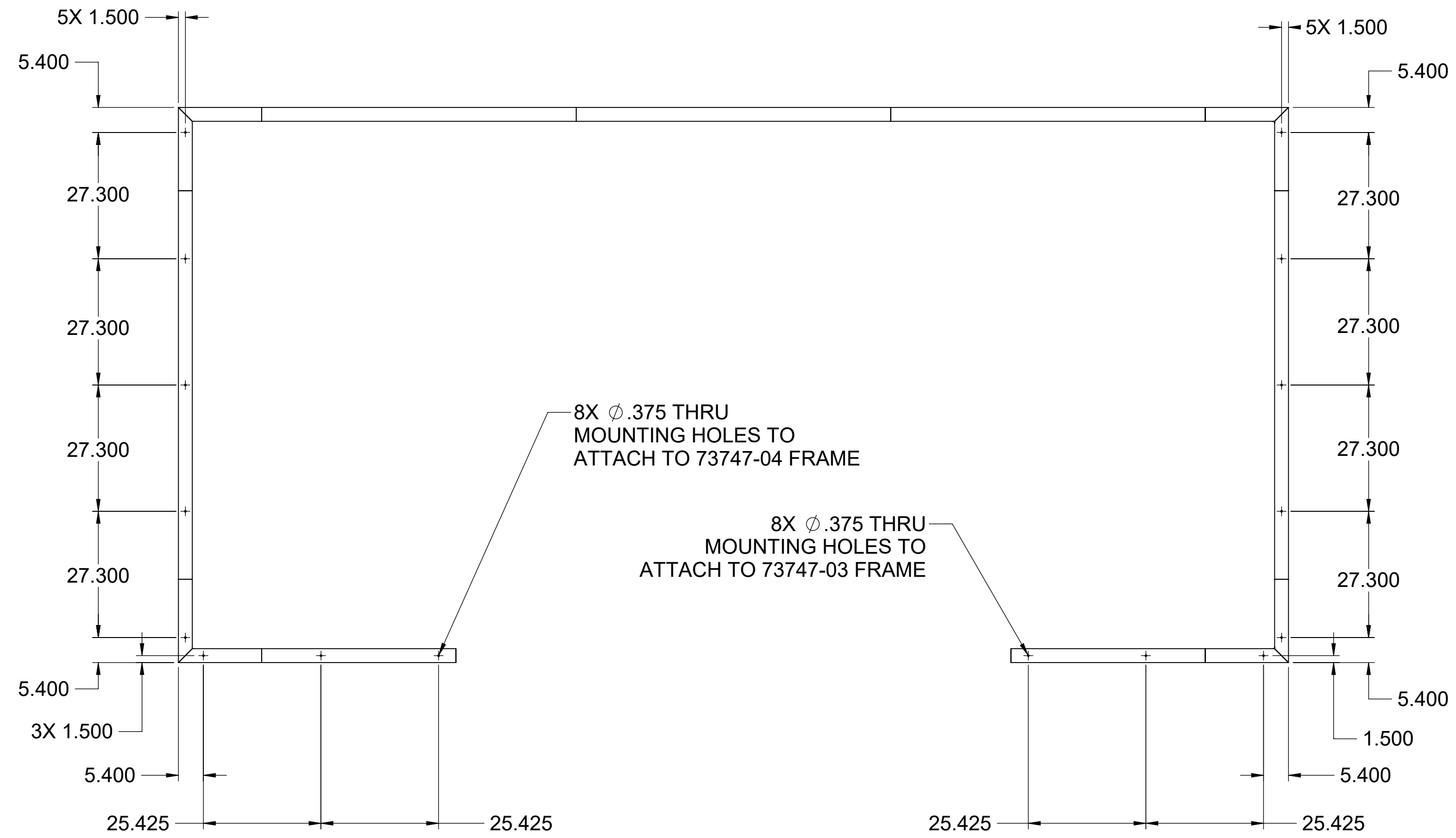

TOP VIEW

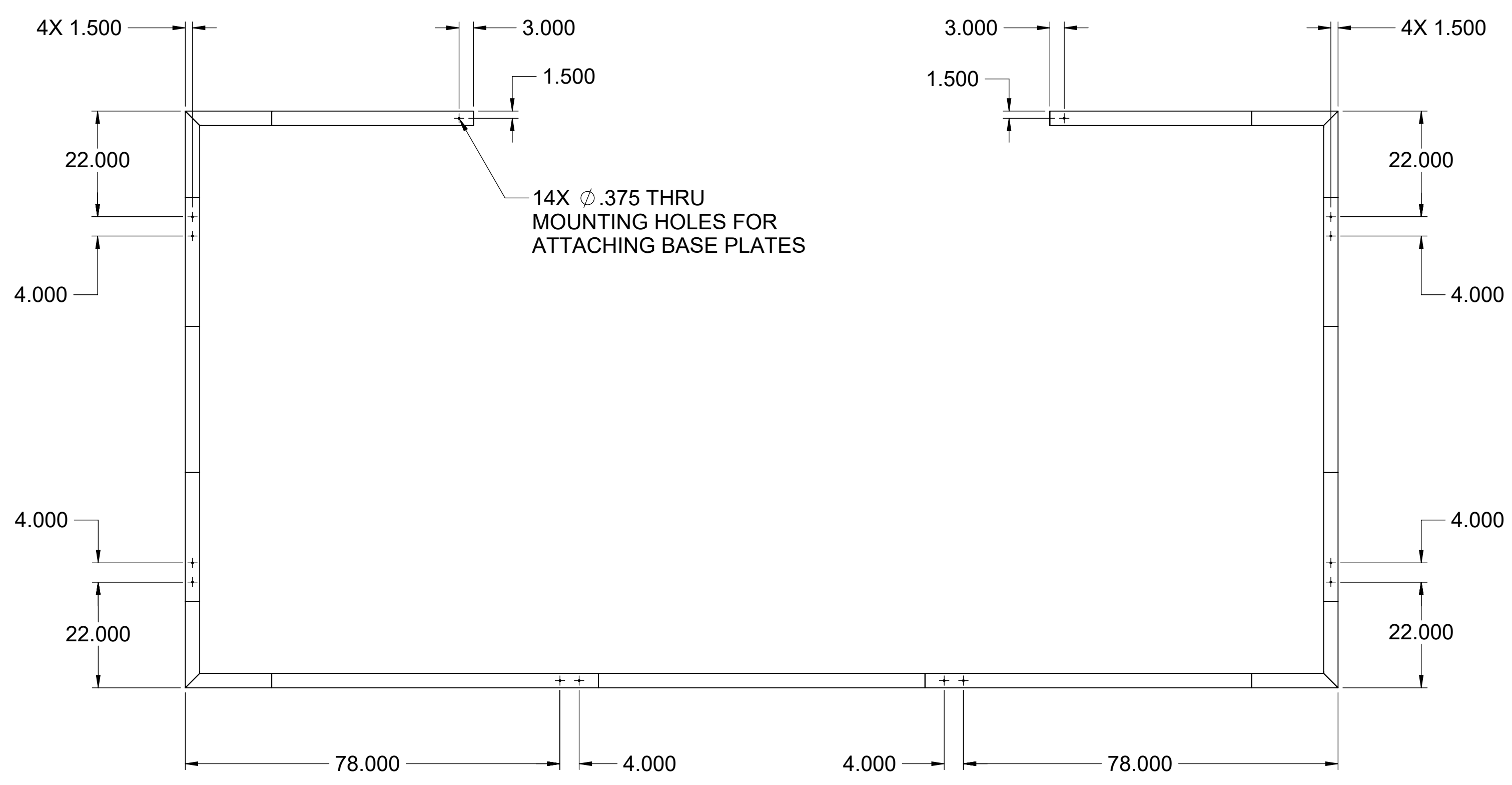

BOTTOM VIEW

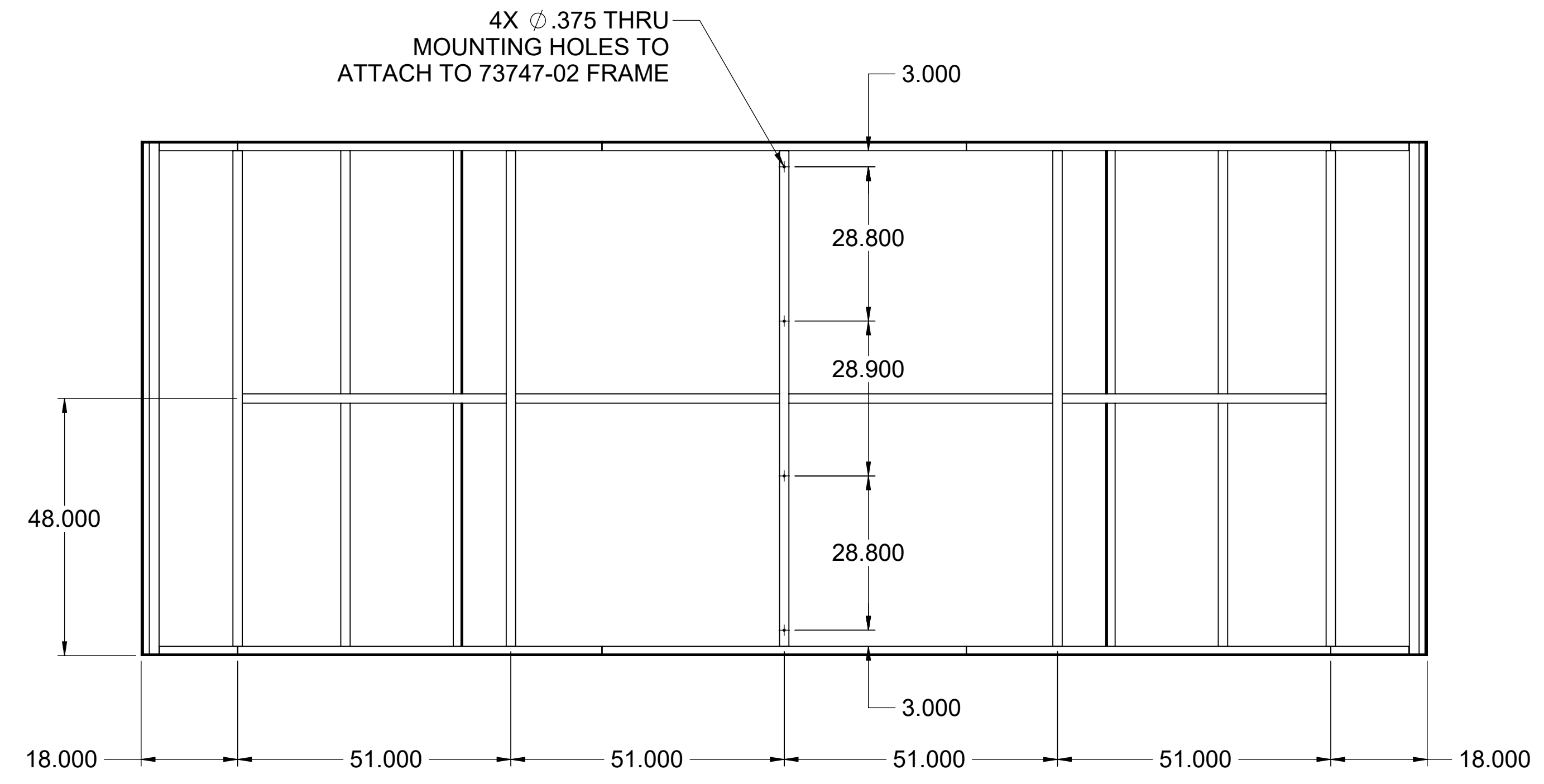

BACK VIEW

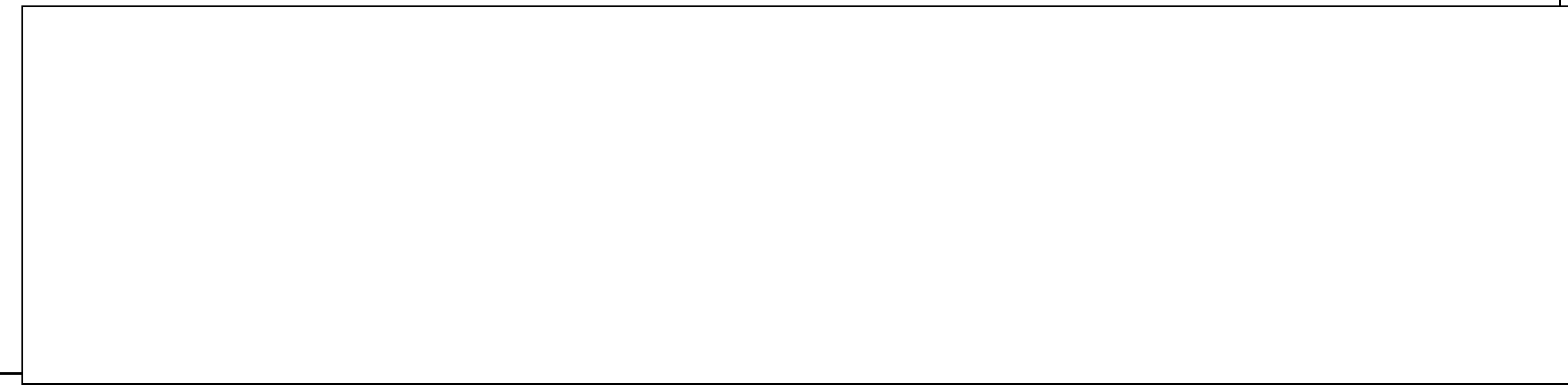

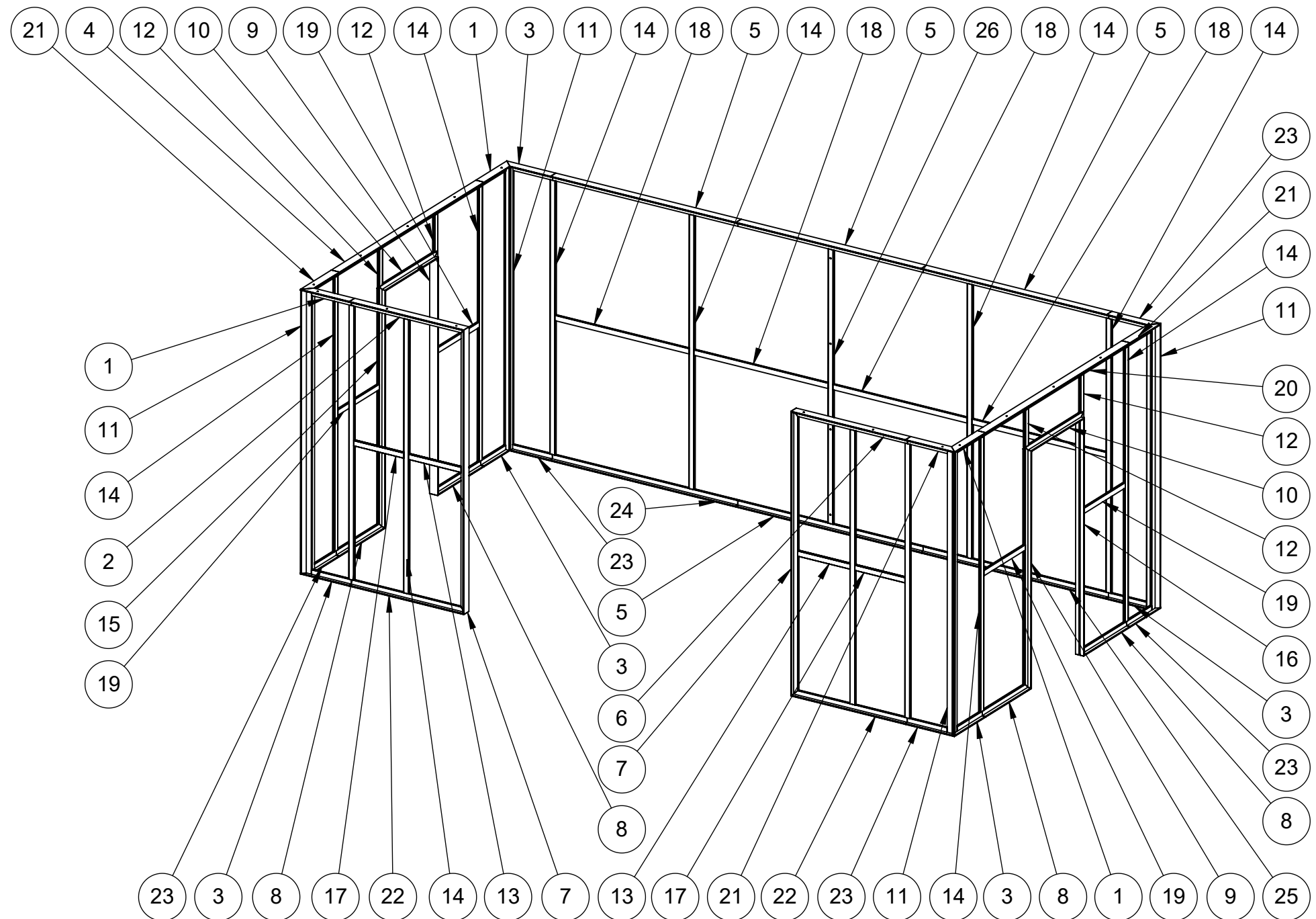

SNAP TUBE CUT-LIST α				
ITEM NO.	PART NUMBER	DESCRIPTION	QTY.	LENGTH
1	73747-01-01-1	FP 2G 02 (FABRIC PROFILE)	3	18
2	73747-01-01-2	FP 2G 02 (FABRIC PROFILE)	1	42
3	73747-01-01-3	FP 2G 02 (FABRIC PROFILE)	5	18
4	73747-01-01-4	FP 2G 02 (FABRIC PROFILE)	1	84
5	73747-01-01-5	FP 2G 02 (FABRIC PROFILE)	4	68
6	73747-01-01-6	FP 2G 02 (FABRIC PROFILE)	1	42
7	73747-01-01-7	FP 2G 02 (FABRIC PROFILE)	2	96
8	73747-01-01-8	FP 2G 02 (FABRIC PROFILE)	4	26.8
9	73747-01-01-9	FP 2G 02 (FABRIC PROFILE)	2	81.75
10	73747-01-01-10	FP 2G 02 (FABRIC PROFILE)	2	33.9
11	73747-01-01-11	FP 4G 04 (FABRIC PROFILE)	4	95.372
12	73747-01-01-12	SP 2L 02 (SUPPORT PROFILE)	4	12.5
13	73747-01-01-13	SP 2L 02 (SUPPORT PROFILE)	2	19.25
14	73747-01-01-14	SP 2L 02 (SUPPORT PROFILE)	12	92.5
15	73747-01-01-15	FP 2G 03 (FABRIC PROFILE)	1	81.75
16	73747-01-01-16	FP 2G 03 (FABRIC PROFILE)	1	81.75
17	73747-01-01-17	SP 2L 02 (SUPPORT PROFILE)	2	18.375
18	73747-01-01-18	SP 2L 02 (SUPPORT PROFILE)	4	49.25
19	73747-01-01-19	SP 2L 02 (SUPPORT PROFILE)	4	24.17
20	73747-01-01-20	FP 2G 02 (FABRIC PROFILE)	1	84
21	73747-01-01-21	FP 2G 02 (FABRIC PROFILE)	3	18
22	73747-01-01-22	FP 2G 02 (FABRIC PROFILE)	2	42
23	73747-01-01-23	FP 2G 02 (FABRIC PROFILE)	5	18
24	73747-01-01-24	FP 2G 02 (FABRIC PROFILE)	1	68
25	73747-01-01-25	FP 2G 02 (FABRIC PROFILE)	1	68
26	73747-01-01-26	SP 2L 02 (SUPPORT PROFILE)	1	92.5



BILL OF MATERIALS			
ITEM NO.	PART NUMBER	DESCRIPTION	QTY.
1	73747-01-01	240"W X 120"DX 96"H ES FRAME	1
2	HD IL 07	SPLICE LOCK	20
3	HD CL 06	CORNER LOCK	12
4	HD SL 01	STRAIGHT LOCK	58

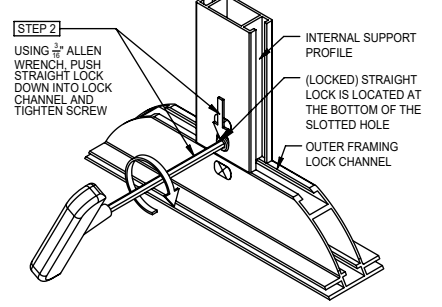
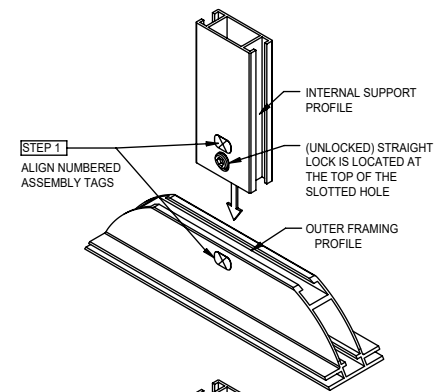

STRAIGHT LOCK CONNECTION
SCALE: FULL

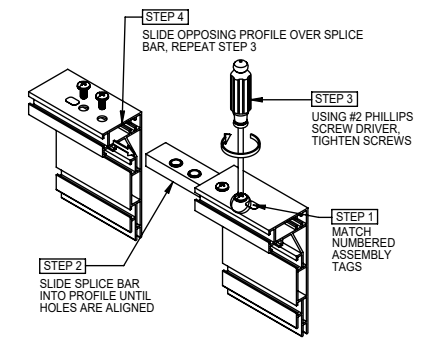

POSITIVE SPLICE LOCK CONNECTION
SCALE: FULL

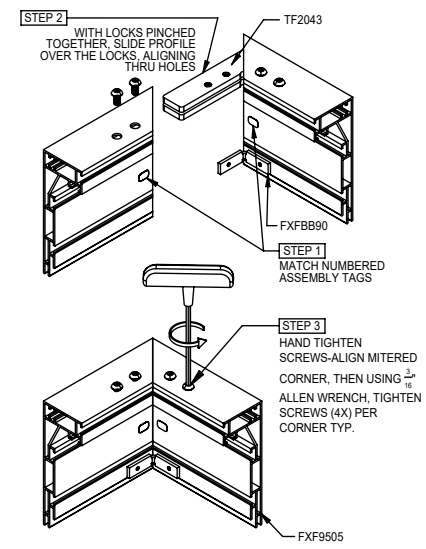

COMPRESSION LOCK CONNECTION
SCALE: FULL

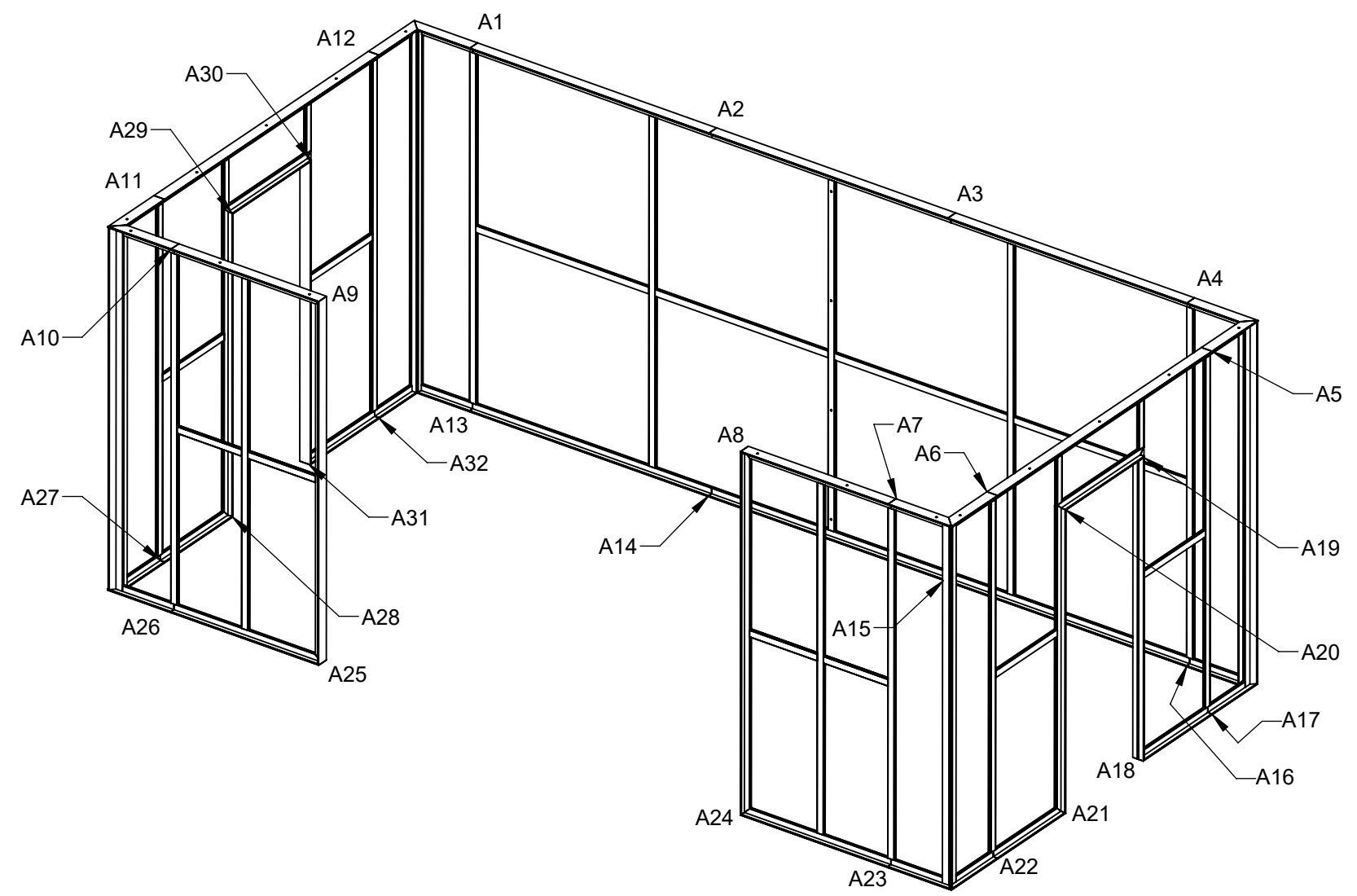

ASSEMBLY ISOMETRIC

X MATCH JOINT TAG WITH NUMBERED DECALS ON FRAME



BILL OF MATERIALS			
ITEM NO.	PART NUMBER	DESCRIPTION	QTY.
1	73747-01-01	240"W X 120"DX 96"H ES FRAME	1
2	HD IL 07	SPLICE LOCK	20
3	HD CL 06	CORNER LOCK	12
4	HD SL 01	STRAIGHT LOCK	58

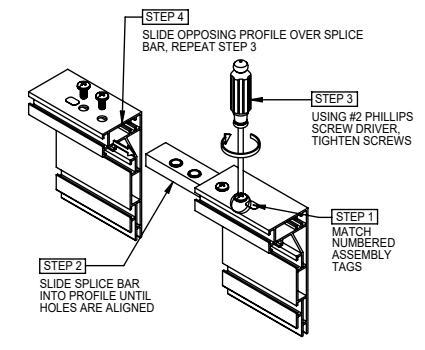
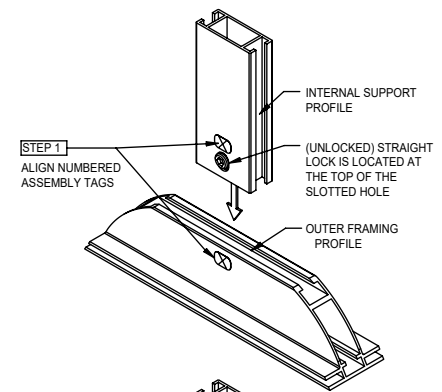

POSITIVE SPLICE LOCK CONNECTION
SCALE: FULL

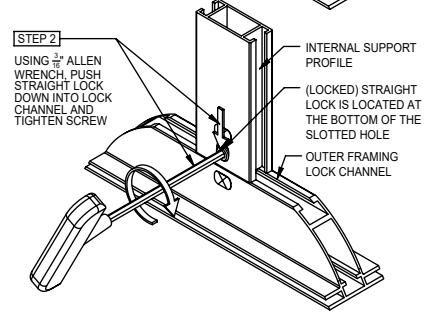

STRAIGHT LOCK CONNECTION
SCALE: FULL

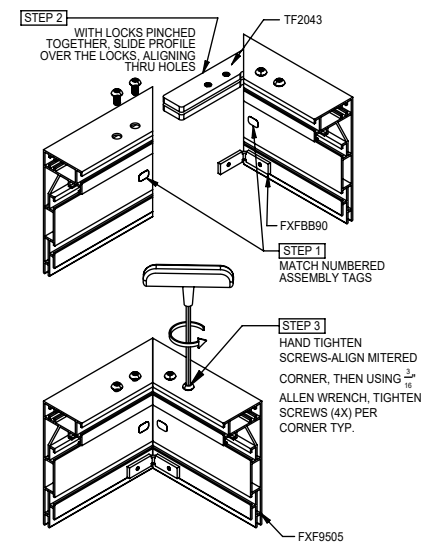
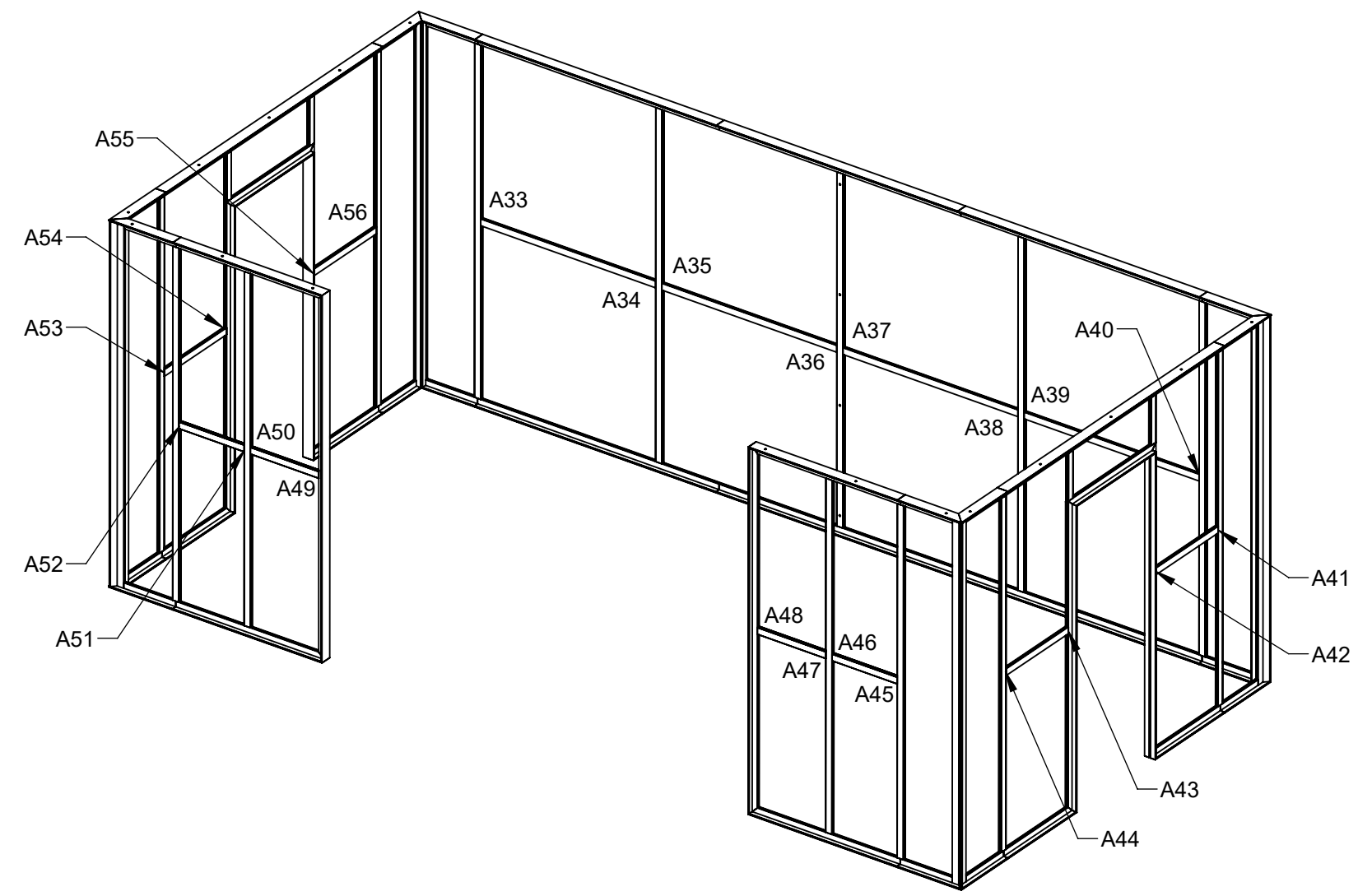

COMPRESSION LOCK CONNECTION
SCALE: FULL

ASSEMBLY ISOMETRIC

X MATCH JOINT TAG WITH NUMBERED DECALS ON FRAME

BILL OF MATERIALS			
ITEM NO.	PART NUMBER	DESCRIPTION	QTY.
1	73747-01-01	240"W X 120"DX 96"H ES FRAME	1
2	HD IL 07	SPLICE LOCK	20
3	HD CL 06	CORNER LOCK	12
4	HD SL 01	STRAIGHT LOCK	58

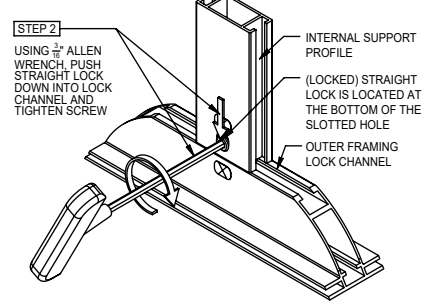
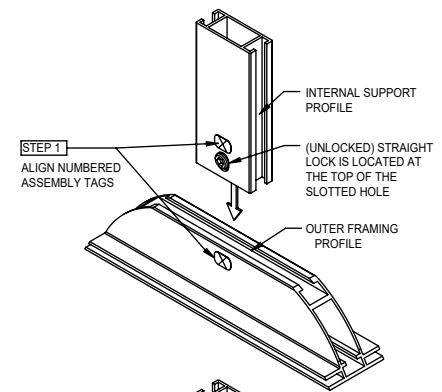

STRAIGHT LOCK CONNECTION
SCALE: FULL

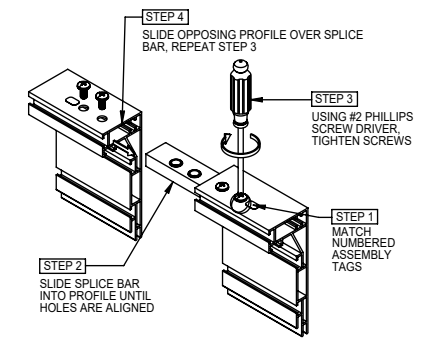

POSITIVE SPLICE LOCK CONNECTION
SCALE: FULL

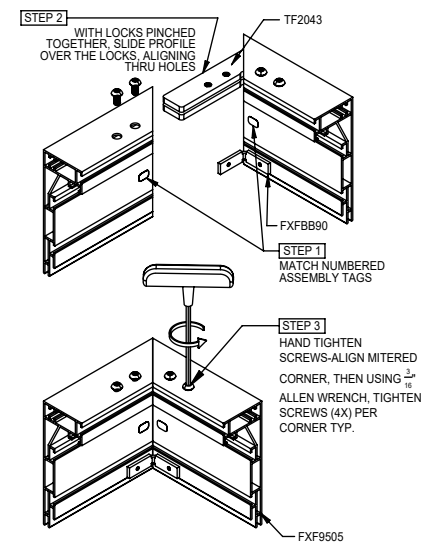

COMPRESSION LOCK CONNECTION
SCALE: FULL

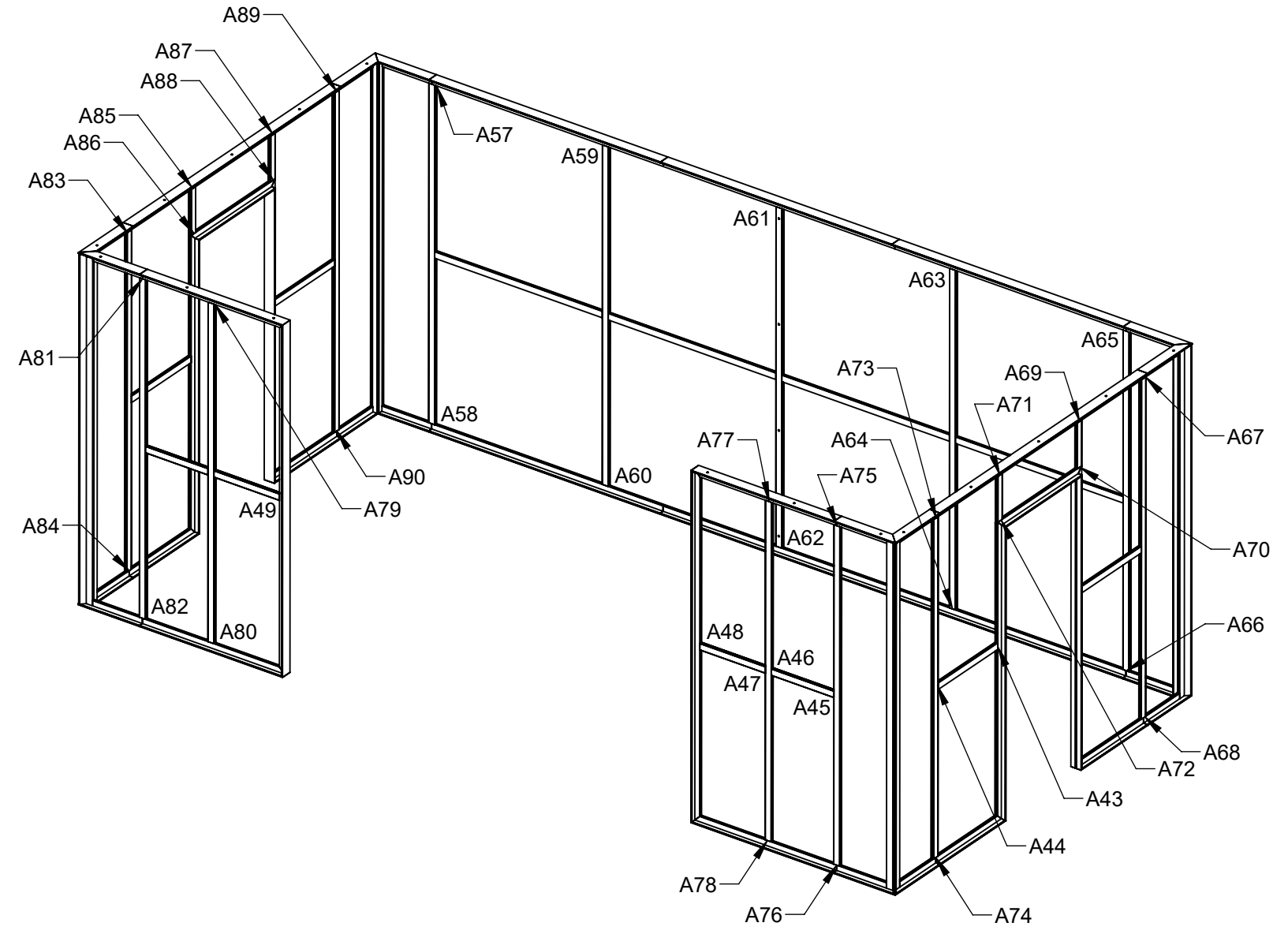

ASSEMBLY ISOMETRIC

X MATCH JOINT TAG WITH NUMBERED DECALS ON FRAME

